

**CABOT MANTANONA LLP**  
Rebecca J. Wrightson, Esq.  
929 South Marine Corps Dr., Ste. 200  
Tamuning, Guam 96913  
Telephone: (671) 646-2001  
Facsimile: (671) 646-0777  
Email: rw@cmlaw.us | as@cmlaw.us

*Attorney for Purchasing Agency Guam Community College*

RECEIVED  
OFFICE OF PUBLIC ACCOUNTABILITY  
PROCUREMENT APPEALS

DATE: 11/5/21

TIME: 9:05 AM LHM BY: JW

FILE NO CPA-PA: 21-013

**BEFORE THE PUBLIC AUDITOR  
PROCUREMENT APPEALS  
TERRITORY OF GUAM**

In the Matter of	)	<b>Appeal No. OPA-PA-21-013</b>
	)	
JJ Global Services,	)	<b>PROCUREMENT RECORD</b>
	)	<b>VOLUME 2</b>
Appellant,	)	
	)	
and	)	
	)	
Guam Community College	)	
	)	
Purchasing Agency.	)	
	)	

Purchasing Agency Guam Community College, by and through its attorney Cabot Mantanona LLP, respectfully submits Volume 2 of its Procurement Record for the above noted appeal.

Volume 2 of the Procurement Record hereby submitted contains pages numbered:

GCC PR0218 – 0414

- Tab 9. Evaluation of bids
- Tab 10. Letters to bidders concerning outcome of bid; Notice of intent to award
- Tab 11. Communications regarding required items and contract
- Tab 12. Formal contract, including all draft versions
- Tab 13. Protest and Response

Respectfully submitted November 5, 2021.

**CABOT MANTANONA LLP**  
*Attorneys for Purchasing Agency*  
**Guam Community College**

By:



**REBECCA J. WRIGHTSON**

**Procurement Appeal No. OPA-PA-21-013**

**Procurement Record**  
**Tab 9**

**MEMORANDUM**

Date: July 1, 2021  
To: Mary A.Y. Okada, Ed.D.  
President  
Via: Rodalyn Gerardo *Ref*  
Vice President, Finance & Administration  
From: Joleen M. Evangelista *JME*  
Procurement & Inventory Administrator  
Subject: Bid Evaluation and Recommendation for Replacement of Building 900 Metal  
Awning Structure  
Bid No: GCC-FB-21-009

The Bid Invitation for the above was advertised in the Guam Daily Post on Thursday, May 13, 2021, the Mandatory Pre-Bid Conference & site visit was held on Wednesday, March 19, 2021. There were three (3) prospective bidders and the Bid Opening was held at 10:15 a.m. on Thursday, June 3, 2021.

There were two (2) bids received from:

1. Clayarch Inc.
2. JJ Global Services

The bids submitted were reviewed and evaluated by:

1. Francisco "Kiko" Palacios, Sustainability & Project Coordinator
2. Inocencio "Shine" San Augustin, Facilities Building Maintenance Superintendent

On June 3, 2021, Alleen de Dios (General Manager) of JJ Global advised via email to correct their price submission for the Black Iron and Galvanized Iron. They advised it was a typo error and galvanized iron cost more than the black iron. JJ Global wanted to switch the two prices submitted for the two options. On June 4, 2021, GCC advised that the bid prices received from JJ Global Services cannot be changed after the Bid Opening. On June 8, 2021, Alleen de Dios advised via email that it is well noted.

Please see the attached bid evaluation completed on June 28, 2021. All bidders submitted all the required documents and responded to the clarifications requested. The bid price breakdown received were as follows:

Options	JJ Global	Clayarch Inc.
1: Black Iron	\$179,590.24	\$183,000.00
2: Galvanized Iron	\$163,263.84	\$192,000.00

It is recommended that the award be made to JJ Global Services for Option 2: Galvanized Iron. They are deemed the lowest, responsive and responsible bidder. The total amount to be awarded for this project is \$163,263.84.

Approved

Disapproved

*Mary A.Y. Okada*  
Mary A.Y. Okada, Ed.D.  
President

**Joleen Evangelista**

---

**From:** Francisco Palacios <francisco.palacios1@guamcc.edu>  
**Sent:** Wednesday, June 30, 2021 11:23 AM  
**To:** Josephine Arceo  
**Cc:** Julie Ulloa-Heath; Joleen Evangelista  
**Subject:** Recommendation to Award GCC-FB-21-009 Building 900 Awning Replacement  
**Attachments:** GCC-FB-21-009 Recommendation to Award with Supporting Documents.pdf

Hafa adai Ms. Josephine,

Please see Recommendation to Award Letter with additional supporting documents to start the Requisition Process for GCC-FB-21-009. Please let me know if you have any questions or concerns.

Best,

--

Francisco "Kiko" Palacios  
Guam Community College  
Planning and Development Dept.  
Sustainability and Project Coordinator  
(w)671-735-5501  
(c) 671-777-8087

"Nature is inexhaustibly sustainable if we care for it. It is our universal responsibility to pass a healthy earth onto future generations."

— Sylvia Dolson



*E-mail administered by Guam Community College*



Planning and Development  
Facilities and Maintenance

MEMORANDUM FOR RECORD

**TO:** Joleen Evangelista, Materials Management Administrator  
**FROM:** Julie Ulloa-Heath, Acting. Asst. Director Planning and Development  
**VIA:** Francisco "Kiko" Palacios, Sustainability and Project Coordinator *fcsp*  
**SUBJECT:** Recommendation to Award – GCC-FB-21-009  
**DATE:** 06/28/2021

Hafa adai,

The Guam Community College's Planning and Development Division along with the Materials Management Office (MMO) had finalized its' plans to initiate the GCC-FB-21-009 Replacement of Building 900 Awning Structure in which MMO had scheduled the Pre-Bid Conference (May 19, 2021), Bid-Opening (June 3, 2021) and Bid Submission Deadline for this project. A Mandatory Site visit was scheduled on May 19, 2021 which occurred right after the Pre-Bid Conference. The Bid was made public via a one day newspaper ad on the Guam Daily Post prior to the Pre-Bid Conference.

Among those who attended the Mandatory Site Visit on May 19, 2021, only two Qualified Contractors made an official submission for the Bid by the deadline date of June 3, 2021. These companies include:

- ClayArch Inc.
- JJ Global Services

A two person Evaluation Team consisting of the Sustainability and Project Coordinator (Francisco Palacios) and the Facility Superintendent (Inocencio San Agustin) was develop to review submissions for this Bid. After evaluating submissions from the two (2) eligible Qualified Contractors the first time, a set of clarification questions were developed by GCC Project Evaluators requesting for clarification for certain items on the Contractor's submission. Both Contractor's were then sent their respective clarification questions by GCC MMO. Both Qualified Contractors responded to these questions and GCC was able to continue with their evaluation for the specified Bid Project.

After the evaluation was completed for both Contractor's submission on Monday, 6.28.2021 GCC had determined that both vendors submitted the necessary documentation (i.e. CPM Chart, Project Narrative, Conceptual Drawing, and the Price Proposal Breakdown) and were responsive to all the requirements of the project. However, JJ Global submitted the lower overall price proposal for the entire project and for both metal options requested for the Bid Project. See Price Proposal Submission Breakdown sheet which details the price proposals of both Contractors.

The GCC P&D is recommending to award this project to *JJ Global Services* for the for the (Galvanize Option). The total cost of the project will be \$163,263.84.

SOW	JJ Global Services	Clayarch Inc.
A.	\$10,355.39	\$9,640.00
B.	\$4,002.08	\$10,250.00
C.	\$72,130.59	\$67,560.00
D.	\$5,252.74	\$10,660.00
E.	\$12,256.38	\$27,470.00

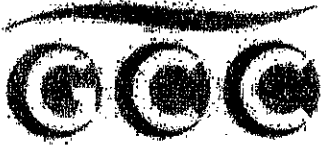

Planning and Development  
Facilities and Maintenance

GUAM COMMUNITY

F.	\$15,170.89	\$15,170.00
G.	\$37,520.41	\$37,520.00
H.	\$4,100.94	\$4,100.00
I.	\$9,630.42	\$9,630.00
<b>TOTAL</b>	<b>\$166,263.84</b> <b>(Galvanize Option)</b>	<b>\$192,000.00</b> <b>Galvanize Option)</b>

Should you have any questions or concerns pertaining to this recommendation, please do not hesitate to contact me.

Francisco "Kiko" E. Palacios  
Sustainability & Project Coordinator

APPROVED:  
Dr. Julie Ulloa-Heath  
Assistant Director, Planning & Development

Inocencio "Shine" San Agustin  
Facility Superintendent



Francisco Palacios <francisco.palacios1@guamcc.edu>

**Clarification request GCC-FB-21-009 Replacement of Building 900 Awning Structure JJ Global**

Aileen de Dios <aileen@jjglobal.services>

Fri, Jun 25, 2021 at 2:56 PM

To: Joleen Evangelista <joleen.evangelista@guamcc.edu>

Cc: Kit Casin <kit.casin@jjglobal.services>, "Luis E. Bustamante" <luis.bustamante34@gmail.com>, materialsmanagement@guamcc.edu, Francisco 'Kiko' Palacios <francisco.palacios1@guamcc.edu>, Julie Ulloa-Heath <julie.ulloaheath@guamcc.edu>, Innocencio San Agustin <Innocencio.sanagustin@guamcc.edu>, Aaron <aaronburger@outlook.com>

Hi Joleen,

Please see formal responses to your inquiries:

1) Please clarify JJ Globals One Year Written Certificate of Warranty as none was mentioned.

---Yes the Certificate of Warranty is one year, per standard.

2) Please clarify JJ Globals demolition and disposal plan as none was mentioned.

---Yes we will comply as per Technical Specification on Items A & B.

---Although plan is not originally required, we will furnish upon award.

3) Please clarify if JJ Global will complete the project within 90 Calendar Days, the provided CPM chart is unclear. Will just need to input Start Days in the equation.

---CPM as shown below is clearly stipulating each line item and tentative days to finish.

Activity start	Activity end	Activity Description	Normal Time	Earliest Time (TE)		Latest Time (TL)		Total Float
				Start (ES)	Finish (EF)	Start (LS)	Finish (LF)	
1	2	Assessment and evaluation of existing structure	3	0	3	0	3	0
1	3	Design Phase	7	0	7	0	7	0
3	4	Application for Building Permit & other Licenses	14	7	21	7	21	0
4	5	Mobilization	3	21	24	21	24	0
5	6	Removal of existing tools, equipment, etc. from the structure	9	24	29	24	29	0
6	7	Removal and disposal of the existing awning (Phase 1)	4	24	28	24	28	0
7	8	Removal and disposal of the existing metal columns and beams (Phase 1)	10	28	38	28	38	0
7	9	Removal and disposal of the existing awning (Phase 2)	4	28	32	44	48	16
9	10	Removal and disposal of the existing metal columns and beams (Phase 2)	10	32	42	32	42	0
8	9	Installation of new metal columns and beams (Phase 1)	10	38	48	38	48	0
10	11	Installation of new metal columns and beams (Phase 2)	10	42	52	42	52	0
10	12	Installation of new rafter system	7	42	49	42	49	0
12	13	Installation of cable bracing	9	49	58	49	58	0
12	14	Installation of new purlins	7	49	56	49	56	0
14	15	Installation of corrugated roof sheet panels	14	56	70	58	70	0
15	16	Application of oil based primer and paint	5	70	75	70	75	0
14	17	Production and submission of as-built plans	7	56	63	68	75	12
15	17	Re-installation of removed tools, equipment, etc. from the structure	5	70	75	70	75	0
17	18	Demobilization	8	78	78	75	78	0

Table 1. Computation for CPM of Awning Structure



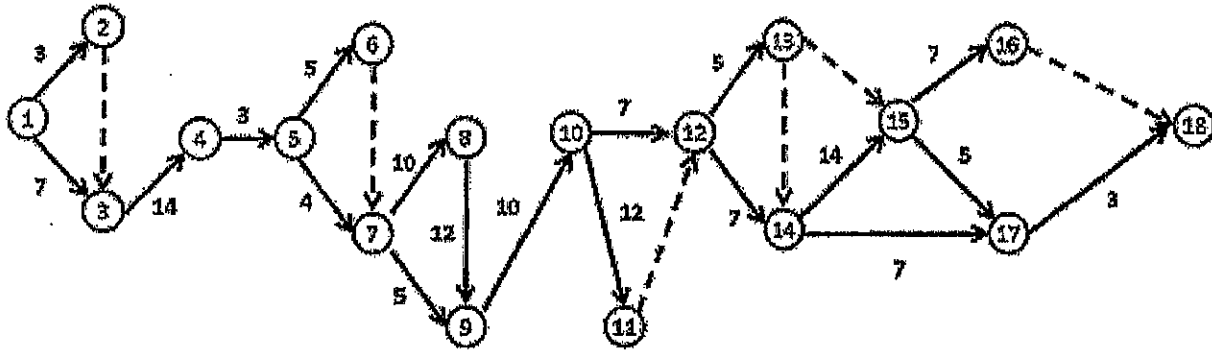

Figure 1. Critical Path Method (CPM) Diagram for Design & Build of Awning Structure

First Line Item shows progress to do from 1-2 will take about 3 (number in between arrows) Estimated Days but we are looking at finishing it "EF" 78-90 days.

Disclosure: 90 Days does not include delays due to weather or natural calamities that are beyond our control and scarcity of materials being available in our Island.

4) Clarify if JJ Global will utilize 22 gauge thickness corrugated roof sheet panels.

---Yes, it's per the required specifications.

6) Please clarify if JJ Global will install new gutters and down spouts.

---Yes, it's included in the proposal.

6) Please clarify if JJ Global will remove and reinstall existing equipment, tools, systems, infrastructure, CCTV, etc... into the new awning structure. This will be determined by GCC reps.

---Yes, kindly refer to Item I in the Bill of Quantities

7) Please clarify if JJ Global will utilize only anti-corrosive fasteners, nuts, bolts etc.. and no metal to metal corrosion reaction as a result of two different metals being in contact.

---Yes, confirmed.

8) Please clarify if the new awning structure will be engineered to withstand 200 mile per hour winds.

---Yes, it is designed to withstand the required wind load.

Thank you Joleen and let me know how else I can further assist.

All the best,

**Aileen de Dios**  
 General Manager  
<http://www.jjglobal.services/>  
 E: aileen@jjglobal.services  
 O: 671-632-1179  
 F: 671-632-3550

[Quoted text hidden]



P.O BOX 12577 TAMUNING, GUAM 96931  
Tel. (871) 646-8842 Fax. (871) 646-8843  
E-mail: admin@clayarchinc.com  
Website: www.clayarchinc.com

Date: June 21, 2021

To: Guam Community College

Attn: Joleen M. Evangelista, Procurement & Inventory Administrator

Subj: Clarification Questions

Ref: GCC-FB-21-009 Replacement of Building 900 Metal Awning Structure

Clayarch, Inc. submits the response for clarification questions as follows:

- 1) Please clarify if Clayarch will remove and reinstall existing equipment, tools, systems, infrastructure, CCTV, etc... into the new awning structure. This will be determined by GCC reps.  
**Response: Clayarch will be removed and reinstalled existing equipment, tools, systems, infrastructure, CCTV, etc. into the new awning structure.**
- 2) Please clarify if rafters are a part of the purlins phase.  
**Response: Clayarch clarify the rafters are a part of the purlins phase.**
- 3) Please clarify if the structure will be engineered to withstand 200 mile per hour winds.  
**Response: Clayarch clarify the structure will be engineered to withstand maximum winds of 200mph.**
- 4) Please clarify if Clayarch will utilize only anti-corrosive fasteners, nuts, bolts etc. and no metal-to-metal corrosion reaction as a result of two different metals being in contact.  
**Response: Clayarch will be utilized only anti-corrosive fasteners, nuts, bolts etc. and no metal-to-metal corrosion reaction as a result of two different metals being in contact.**

Yours sincerely

A handwritten signature in black ink, appearing to read 'Min Chul Kong', is written over a light blue horizontal line.

MIN CHUL KONG / VICE PRESIDENT

GCC PR0224



Did Evaluation .

Vendor: JJ Global  
Evaluator: Francisco Palacios  
GCC Bid No:  
GCC-FB-21-009  
6/15/2021

Bid Description:  
Replacement of Building 900  
Metal Awning Structure

May 2021

Page 1 of 7

Guam Community College (GCC) is soliciting the service of a qualified contractor to replace the dilapidated awning structure located at building 900 and including (but not limited to) the following.

I = Met

O = Not Met

Cor\* = clarify?

**SCOPE OF WORK (SOW):**

**A. General Requirements of the Scope of Work:**

The Qualified Contractor for this SOW shall:

- ① 1. Conduct a holistic assessment, verify existing conditions, and conduct all the necessary work for a design build concept to replace the dilapidated awning located at building 900 to include all component elements for complete functionality, operation, safety and code-compliance (i.e., civil, mechanical, infrastructure, etc.).
- ① 2. Provide contractual services to include at a minimum the following component elements – assessment, estimation, replacement requirements, certification, and as-build drawings
- ① 3. Ensure “good standings” with governing authorities having jurisdiction with the SOW (e.g., Guam Department of Public Works, Department of Revenue and Taxation, Guam Contractor’s License Board, etc.) prior to commencing work related to this SOW.
- ① 4. When appropriate, obtain and pay requisite permits, clearances, and approvals, from all applicable government of Guam agencies.
- ① 5. A mandatory site visit is scheduled for 10:00 a.m. at the project site on Wednesday, May 19, 2021. Contact Josephine Arceo at 735-5521 if accommodative service or an additional site visit is needed.
- ① 6. Warranty: Qualified Contractor shall assure against defective materials and workmanship by providing a one (1) year written Certificate of Warranty. The Certificate of Warranty shall commence immediately upon GCC’s explicit acceptance of the project. The Certificate of Warranty shall honor all product warranties and include the cost of all parts, workmanship, and related labor fees. Qualified Contractor must provide and honor all written product warranties.   
→ see clarification responses.
- ① 7. When awarded, the Qualified Contractor shall submit a list and have all supplies and materials for GCC’s explicit approval prior to their use or installation. All supplies, materials, and incidentals included in this SOW shall be new and of the most suitable grade for the purpose intended.
- ① 8. Qualified Contractor’s employees assigned to this project shall be cleared from the Guam Sex-Offender Registry and have a GCC badge clearly visible on his/her person.



JJ Global page 2  
Kiko's Eval

GCC Bid No:  
GCC-FB-21-009

**Bid Description:**  
**Replacement of Building 900**  
**Metal Awning Structure**

May 2021

Page 2 of 7

9. The Qualified Contractor shall conform to all Occupational Safety and Health Administration (OSHA) regulations, the National Electrical Code (NEC), Environmental Protection Agency and the National Fire Protection Association (NFPA). Clean, maintain, protect work site, and newly installed work as necessary throughout the project period. Provide suitable protective covering on newly installed work when reasonably required to mitigate damage (e.g., during inclement weather) until such time the project is accepted by GCC. Before commencing work, the Qualified Contractor shall coordinate and have in place necessary provisions to protect adjacent building properties for safety, to minimize disruptions and prevent ANY potential hazards. For example, relocate contents away from immediate work area to unoccupied location as work requirements dictate.

①

Dfap → will furnish upon award. See response

10. Properly dispose and recycle all waste, debris, rubbish, etc. associated with the project legally and off-site. Do not allow debris to accumulate at the project site.

①

11. Take all precautions to assure that GCC's stakeholders (students, employees, and visitors) remain out of harm's way throughout the project. The Qualified Contractor shall properly block off the project site and use appropriate signage.

①

12. GCC's hours of operation is Monday through Thursday, 7:30 a.m. to 10 p.m., Friday from 7:30 a.m. to 6:00 pm, and Saturday from 7:30 a.m. to 12 p.m. GCC also recognizes Government of Guam's holidays. The Qualified Contractor's request to work on campus outside of GCC's hours of operation must be preapproved by Planning and Development Department.

①

13. The Qualified Contractor and her/his employees shall adhere to GCC's Tobacco and Betel Nut (Pugu'a) Free Policy 175:

①

- a. DO NOT use tobacco products while on Guam Community College property.
- b. DO NOT use electronic cigarette (e-cigs) devices while on Guam Community College property.
- c. DO NOT chew or spit pugu'a or chewing tobacco while on Guam Community College property.



14. The Qualified Contractor and her/his employees shall adhere to Public Health and GCC's COVID19 guidelines on campus at all times;

①

15. Correct defective work to meet SOW requirements.

①

16. The project is deemed complete by the Qualified Contractor's submission of all warranties, as-build, GCC's formal inspection, and GCC's acceptance of the project for its intended use.

①



W Global page 3  
Kiko's Eval

GCC Bid No:  
GCC-FB-21-009

**Bid Description:**  
**Replacement of Building 900**  
**Metal Awning Structure**

May 2021

Page 3 of 7

① 17. Submit a price proposal having an itemized cost such that GCC may award the project based on the "...lowest, most responsive..." price proposal based on the Scope of Work and related requirements (A. General Requirements of the Scope of Work and B. Specific Requirements of the Scope of Work).

18. Qualified Contractor shall deliver a complete price proposal packet to include the following (18a-18e):

- ① a. A Narrative (required document) describing how the Qualified Contractor will address this project's SOW;
- ① → b. A Critical Path Method (CPM) chart (required document) to illustrate the Qualified Contractor's timeline to complete the project within ninety (90) consecutive calendar days upon receipt of a purchase order and inclusive of the building permit process and material lead-time;
- ① ⊗ c. Submission of a conceptual design illustrating the size and design of the awning.
- ① ⊗ d. Submission of Bid (with required documents): one original and two complete copies; and
- e. Cost breakdown for:

• Clarify measurements on conceptual design.  
• Clarify CPM chart? what does this mean? Clarify that the project will be completed in 90 calendar Days.

1. Building 900 Awning Bid Price Sheet:

Description of Work	Cost for Supplies, Materials, etc..	Cost for Labor	Total
a. Removal and disposal of the existing awning. (i.e. Corrugated roof sheet panels, purlins, rafters, etc...)		\$10,355.39	\$10,355.39
b. Removal and disposal of the existing metal columns and beams		\$4,002.08	\$4,002.08
c. Installation of new metal columns and beams (Option 1 for Black Iron and Option 2 for Galvanized)	\$70,087.18 (B1) \$53,760.79 (G)	\$18,369.81	\$88,456.99 (B1) \$72,130.59 (G)
d. Installation of cable bracing at three (3) specific locations	\$3,751.95	\$1,500.78	\$5,252.74
e. Installation of new Purlins, S-layer and 2'-6" overlap including all component elements	\$8,754.56	\$3,501.82	\$12,256.38
f. Installation of new rafter system including all component elements	\$16,456.27	\$1,645.63	\$18,101.89



g. Installation of 22 gauge thickness corrugated roof sheet panels to include roof sealant for fastener and joint protection and leak prevention.	\$ 22,511.72	\$9,004.09	\$ 31,514.41
h. Application of oil based primer and two (2) coats final paint on corrugated roof sheet panels (top and bottom)	\$5,402.81	\$2,161.13	\$7,563.94
i. Removal and reinstallation of additional tools, equipment, infrastructure, etc... into the new awning structure.		\$ 2,084.42	\$ 2,084.42
Total Project Bid Price			\$ 179,590.24 (B.I.) \$ 163,263.84 (G)

- ① e. Submit ALL required documents (A. General Requirements of the Scope of Work (SOW) and B. Technical Specifications of the SOW), before **June 03, 2021** to:  
 Joleen Evangelista, Procurement & Inventory Administrator  
 Materials Management Office  
 Guam Community College  
 One Sesame Street  
 Student Services and Administration Building, Room 2105  
 Mangilao, Guam 96913

18. GCC shall be indemnified for any under-estimations / oversights attributed to the Qualified Contractor's lack of due diligence or wrongful assumptions.

**B. Technical Specifications:**

1. Awning: The new awning design shall be identical to the existing awning system at building 900.
- a. Removal and disposal of existing metal awning to include sheet panels, purlins, rafters and all component elements;
  - b. Removal and disposal of existing metal columns and beams;
  - c. Installation of new metal columns and beams with oil-based primer and two (2) coat final paint;
  - d. Installation of cable bracing at 3 specific locations;
  - e. Installation of purlins S-layer and 2'-6" overlap;
  - f. Installation of rafter system;
  - g. Installation of 22-gauge thickness corrugated roof sheet panels
  - h. Installation of gutter and downspout.
  - i. Removal and reinstallation of additional tools, equipment, infrastructure, etc... that were a part of the original awning structure (to be determined by Program Deans, Department Chairs and Faculty);
2. The Qualified Contractor shall ensure the new awning structure shall be properly and securely integrated into the building 900 structure;



PAGE 4 JT GLOBAL  
SHINE EVAL

**Bid Description:**  
**Replacement of Building 900**  
**Metal Awning Structure**

**GCC Bid No:**  
**GCC-FB-21-009**

May 2021

Page 4 of 6

i. Removal and reinstallation of additional tools, equipment, infrastructure, etc... into the new awning structure.			
Total Project Bid Price			

- e. Submit ALL required documents (A. General Requirements of the Scope of Work (SOW) and B. Technical Specifications of the SOW), before June 03, 2021 to:

Joleen Evangelista, Procurement & Inventory Administrator  
 Materials Management Office  
 Guam Community College  
 One Sesame Street  
 Student Services and Administration Building, Room 2105  
 Mangilao, Guam 96913

- ① 18. GCC shall be indemnified for any under-estimations / oversights attributed to the Qualified Contractor's lack of due diligence or wrongful assumptions.

**B. Technical Specifications:**

1. Awning: The new awning design shall be identical to the existing awning system at building 900.
- ① ② a. Removal and disposal of existing metal awning to include sheet panels, purlins, rafters and all component elements;
  - ① ③ b. Removal and disposal of existing metal columns and beams;
  - ① ④ c. Installation of new metal columns and beams with oil-based primer and two (2) coat final paint;
  - ① ⑤ d. Installation of cable bracing at 3 specific locations;
  - ① ⑥ e. Installation of purlins S-layer and 2'-6" overlap;
  - ① ⑦ f. Installation of rafter system;
  - ① ⑧ g. Installation of 22-gauge thickness corrugated roof sheet panels
  - ① ⑨ h. Installation of gutter and downspout.
  - ① ⑩ i. Removal and reinstallation of additional tools, equipment, infrastructure, etc... that were a part of the original awning structure (to be determined by Program Deans, Department Chairs and Faculty);
- ① 2. The Qualified Contractor shall ensure the new awning structure shall be properly and securely integrated into the building 900 structure;
- ① ③ 3. The Qualified Contractor shall ensure the use of only anti-corrosive fasteners, nuts, bolts, etc... and no metal to metal corrosion reactions as a result of two different metals being in contact;
- ① ④ 4. The Qualified contractor shall ensure absolutely no leaks at any point of the new awning structure roof;
- ① ⑤ 5. The Qualified Contractor shall ensure the structure is engineered to withstand maximum sustained winds of 200 miles-per hour.
- ① ⑥ 6. Refer to the attached Exhibit #1

[GUAM COMMUNITY COLLEGE-BUILDING 900 METAL AWING]

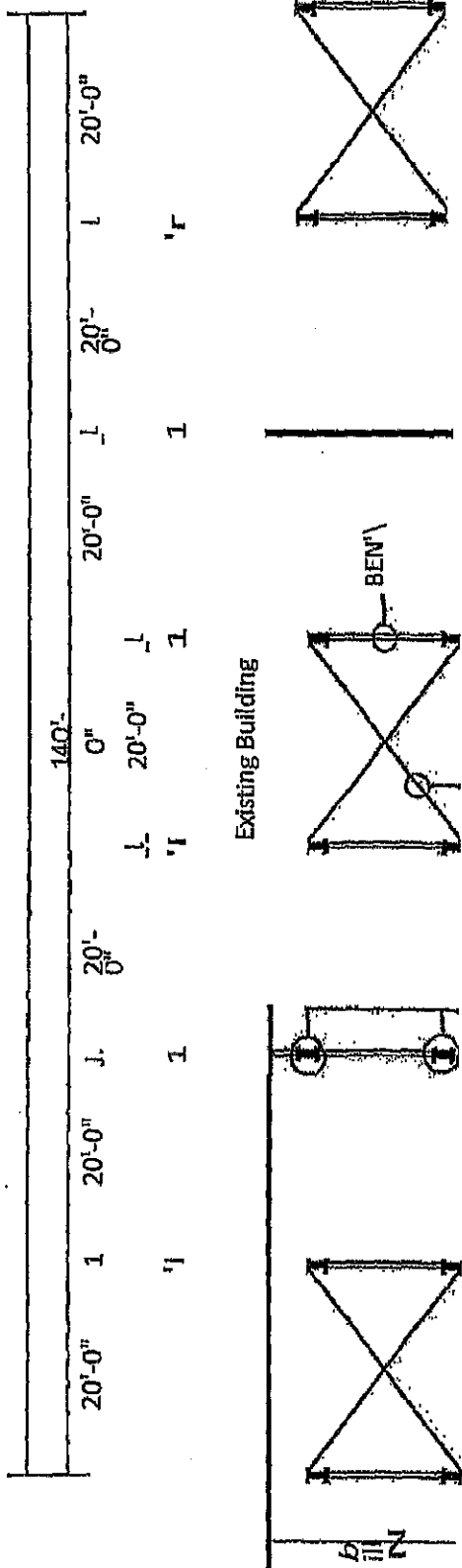

COLUMN AND BEAM PLAN

TRUSS BRACKET

COL-UHN

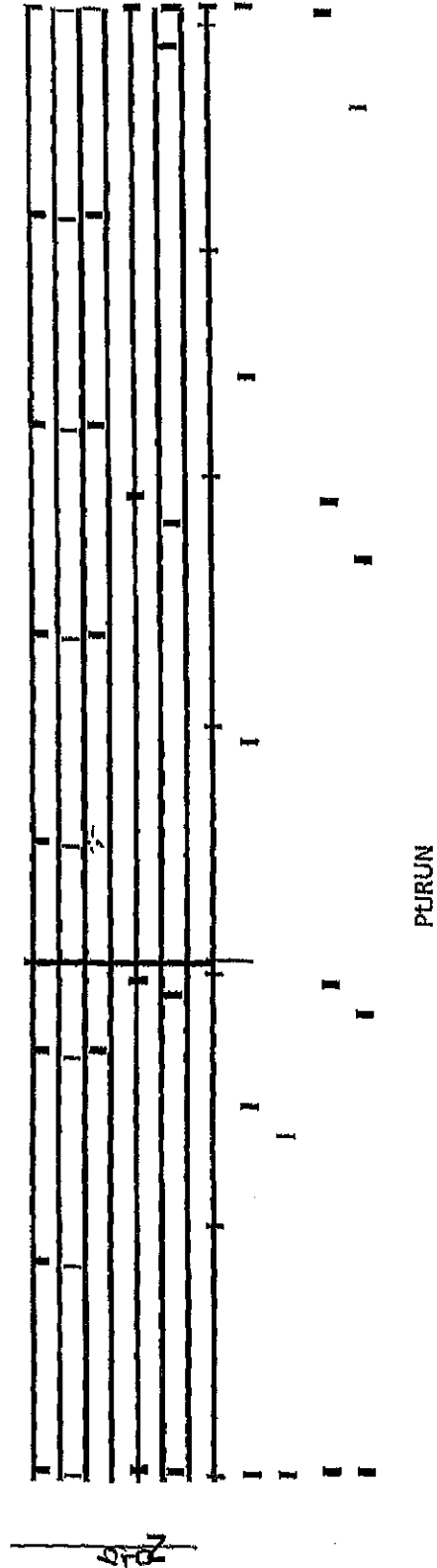

PURUN



ROOF PURLIN PLAN

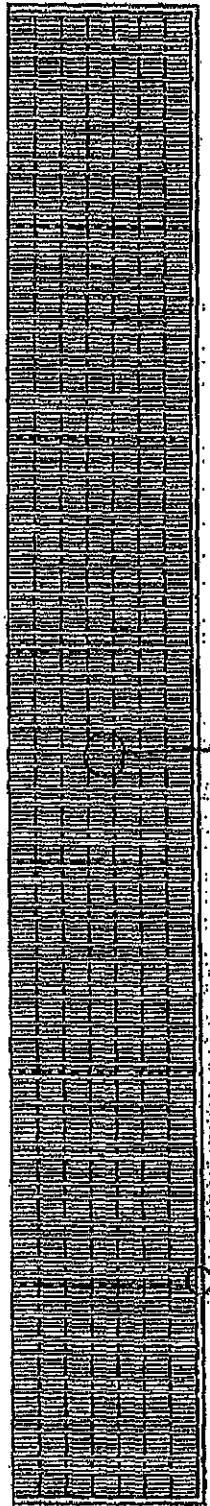

ROOF SHEETING PLAN

L ROOF SHEET N"EL

L GUTTER / DOWN SPOUT

28



Evaluation ~~for~~ onnes . page 1

Francisco Palacios  
Vendor: Clayarch  
GCC Bid No:  
GCC-FB-21-009

**Bid Description:**  
**Replacement of Building 900  
Metal Awning Structure**

May 2021

Page 1 of 7

1st Session: 6/15/2021

Guam Community College (GCC) is soliciting the service of a qualified contractor to replace the dilapidated awning structure located at building 900 and including (but not limited to) the following.

**SCOPE OF WORK (SOW):**

**A. General Requirements of the Scope of Work:**

The Qualified Contractor for this SOW shall:

- ① 1. Conduct a holistic assessment, verify existing conditions, and conduct all the necessary work for a design build concept to replace the dilapidated awning located at building 900 to include all component elements for complete functionality, operation, safety and code-compliance (i.e., civil, mechanical, infrastructure, etc.).
- ① 2. Provide contractual services to include at a minimum the following component elements – assessment, estimation, replacement requirements, certification, and as-build drawings
- ① 3. Ensure "good standings" with governing authorities having jurisdiction with the SOW (e.g., Guam Department of Public Works, Department of Revenue and Taxation, Guam Contractor's License Board, etc.) prior to commencing work related to this SOW.
- ① 4. When appropriate, obtain and pay requisite permits, clearances, and approvals, from all applicable government of Guam agencies.
- ① 5. A mandatory site visit is scheduled for 10:00 a.m. at the project site on Wednesday, May 19, 2021. Contact Josephine Arceo at 735-5521 if accommodative service or an additional site visit is needed.
- ① 6. Warranty: Qualified Contractor shall assure against defective materials and workmanship by providing a one (1) year written Certificate of Warranty. The Certificate of Warranty shall commence immediately upon GCC's explicit acceptance of the project. The Certificate of Warranty shall honor all product warranties and include the cost of all parts, workmanship, and related labor fees. Qualified Contractor must provide and honor all written product warranties.
- ① 7. When awarded, the Qualified Contractor shall submit a list and have all supplies and materials for GCC's explicit approval prior to their use or installation. All supplies, materials, and incidentals included in this SOW shall be new and of the most suitable grade for the purpose intended.
- ① 8. Qualified Contractor's employees assigned to this project shall be cleared from the Guam Sex Offender Registry and have a GCC badge clearly visible on his/her person.



Clayarch Inc Page 2

Kiko's Evaluation

GCC Bid No:

GCC-FB-21-009

**Bid Description:**  
**Replacement of Building 900**  
**Metal Awning Structure**

May 2021

Page 2 of 7

- ① 9. The Qualified Contractor shall conform to all Occupational Safety and Health Administration (OSHA) regulations, the National Electrical Code (NEC), Environmental Protection Agency and the National Fire Protection Association (NFPA). Clean, maintain, protect work site, and newly installed work as necessary throughout the project period. Provide suitable protective covering on newly installed work when reasonably required to mitigate damage (e.g., during inclement weather) until such time the project is accepted by GCC. Before commencing work, the Qualified Contractor shall coordinate and have in place necessary provisions to protect adjacent building properties for safety, to minimize disruptions and prevent ANY potential hazards. For example, relocate contents away from immediate work area to unoccupied location as work requirements dictate.
- ① 10. Properly dispose and recycle all waste, debris, rubbish, etc. associated with the project legally and off-site. Do not allow debris to accumulate at the project site.
- ① 11. Take all precautions to assure that GCC's stakeholders (students, employees, and visitors) remain out of harm's way throughout the project. The Qualified Contractor shall properly block off the project site and use appropriate signage.
- ① 12. GCC's hours of operation is Monday through Thursday, 7:30 a.m. to 10 p.m., Friday from 7:30 a.m. to 6:00 pm, and Saturday from 7:30 a.m. to 12 p.m. GCC also recognizes Government of Guam's holidays. The Qualified Contractor's request to work on campus outside of GCC's hours of operation must be preapproved by Planning and Development Department.
- ① 13. The Qualified Contractor and her/his employees shall adhere to GCC's Tobacco and Betel Nut (Pugu'a) Free Policy 175:
  - a. DO NOT use tobacco products while on Guam Community College property.
  - b. DO NOT use electronic cigarette (e-cigs) devices while on Guam Community College property.
  - c. DO NOT chew or spit pugu'a or chewing tobacco while on Guam Community College property.
- ① 14. The Qualified Contractor and her/his employees shall adhere to Public Health and GCC's COVID19 guidelines on campus at all times;
- ① 15. Correct defective work to meet SOW requirements.
- ① 16. The project is deemed complete by the Qualified Contractor's submission of all warranties, as-built, GCC's formal inspection, and GCC's acceptance of the project for its intended use.



Clayarch Inc page 3  
Kiko's Evaluation

**GCC Bid No:**  
**GCC-FB-21-009**

**Bid Description:**  
**Replacement of Building 900**  
**Metal Awning Structure**

May 2021

Page 3 of 7

17. Submit a price proposal having an itemized cost such that GCC may award the project based on the "...lowest, most responsive..." price proposal based on the Scope of Work and related requirements (A. General Requirements of the Scope of Work and B. Specific Requirements of the Scope of Work).

18. Qualified Contractor shall deliver a complete price proposal packet to include the following (18a-18e):

- ① a. A Narrative (required document) describing how the Qualified Contractor will address this project's SOW;
- ① b. A Critical Path Method (CPM) chart (required document) to illustrate the Qualified Contractor's timeline to complete the project within ninety (90) consecutive calendar days upon receipt of a purchase order and inclusive of the building permit process and material lead-time;
- ① c. Submission of a conceptual design illustrating the size and design of the awning.
- ① d. Submission of Bid (with required documents): one original and two complete copies; and
- e. **Cost breakdown for:**

**1. Building 900 Awning Bid Price Sheet:**

Description of Work	Cost for Supplies, Materials, etc..	Cost for Labor	Total
a. Removal and disposal of the existing awning. (i.e. Corrugated roof sheet panels, purlins, rafters, etc...)		\$9,440.00	\$9,440.00
b. Removal and disposal of the existing metal columns and beams		\$10,250.00	\$10,250.00
c. Installation of new metal columns and beams (Option 1 for Black Iron and Option 2 for Galvanized)	\$34,240.00 \$43,240.00	\$24,320.00	\$58,560.00 (Black Iron) \$67,560.00 (Galvanized)
d. Installation of cable bracing at three (3) specific locations	\$6,500.00	\$4,100.00	\$10,600.00
e. Installation of new Purlins, S-layer and 2'-6" overlap including all component elements	\$15,580.00	\$11,890.00	\$27,470.00
f. Installation of new rafter system including all component elements	\$6,500.00	\$8,610.00	\$15,170.00



Clayarch Inc. page 4  
 Kiko's Evaluation  
 GCC Bid No:  
 GCC-FB-21-009

**Bid Description:**  
 Replacement of Building 900  
 Metal Awning Structure

May 2021

Page 4 of 7

g. Installation of 22 gauge thickness corrugated roof sheet panels to include roof sealant for fastener and joint protection and leak prevention.	\$ 21,320.00	\$ 16,200.00	\$ 37,520.00
h. Application of oil based primer and two (2) coats final paint on corrugated roof sheet panels (top and bottom)	\$ 2,050.00	\$ 2,050.00	\$ 4,100.00
i. Removal and reinstallation of additional tools, equipment, infrastructure, etc... into the new awning structure.	\$ 2,400.00	\$ 7,170.00	\$ 9,570.00
Total Project Bid Price			\$ 143,000.00 (Black Iron) \$ 192,000.00 (Galvanize)

- ① e. Submit ALL required documents (A. General Requirements of the Scope of Work (SOW) and B. Technical Specifications of the SOW), before June 03, 2021 to:  
 Joleen Evangelista, Procurement & Inventory Administrator  
 Materials Management Office  
 Guam Community College  
 One Sesame Street  
 Student Services and Administration Building, Room 2105  
 Mangilao, Guam 96913

18. GCC shall be indemnified for any under-estimations / oversights attributed to the Qualified Contractor's lack of due diligence or wrongful assumptions.

**B. Technical Specifications:**

1. Awning: The new awning design shall be identical to the existing awning system at building 900.

- ① a. Removal and disposal of existing metal awning to include sheet panels, purlins, rafters and all component elements;
- ① b. Removal and disposal of existing metal columns and beams;
- ① c. Installation of new metal columns and beams with oil-based primer and two (2) coat final paint;
- ① d. Installation of cable bracing at 3 specific locations;
- ① e. Installation of purlins S-layer and 2'-5" overlap;
- ① f. Installation of rafter system;
- ① g. Installation of 22-gauge thickness corrugated roof sheet panels
- ① h. Installation of gutter and downspout.
- ① i. Removal and reinstallation of additional tools, equipment, infrastructure, etc... that were a part of the original awning structure (to be determined by Program Deans, Department Chairs and Faculty);

Clarify: if the contractor will remove existing tools, equipment, infrastructure, to include but not limited to: tools, cctv equipment, lights, Racking (metal), etc...

2. The Qualified Contractor shall ensure the new awning structure shall be properly and securely integrated into the building 900 structure;



Clayarch inc. page 5

Kiko's Evaluation

**Bid Description:**  
**Replacement of Building 900**  
**Metal Awning Structure**

**GCC Bid No:**  
**GCC-FB-21-009**

May 2021

Page 5 of 7

- ① → ③ 3. The Qualified Contractor shall ensure the use of only anti-corrosive fasteners, nuts, bolts, etc... and no metal to metal corrosion reactions as a result of two different metals being in contact;
- ① ④ 4. The Qualified contractor shall ensure absolutely no leaks at any point of the new awning structure roof;
- ① ⑤ 5. The Qualified Contractor shall ensure the structure is engineered to withstand maximum sustained winds of 200 miles-per hour.
- 6. Refer to the attached Exhibit #1

- ⑥ Clarify if rafters are a part of the purlins ?
  - ⑥ Clarify if the structure will be engineered to withstand 200 mph winds ?
- Questions / Clarifications sent to Clayarch, they responded on June 21, 2021.

After responses were received from Clayarch on June 21, 2021, The evaluation team continued its evaluation of their responses for the four (4) clarification questions on June 23, 2021. The evaluation team concluded the Clayarch Bid Submission to be responsive to all the General and Specific Requirements of this Bid Project.

Francisco E. Palacios

[GUAM COMMUNITY COLLEGE-BUILDING 900 METAL AWING]

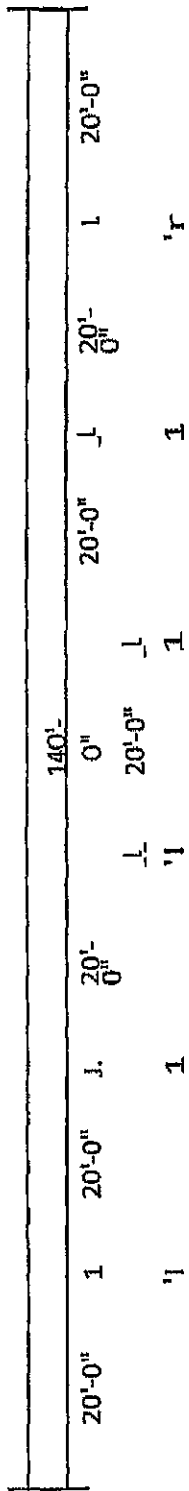

Existing Building

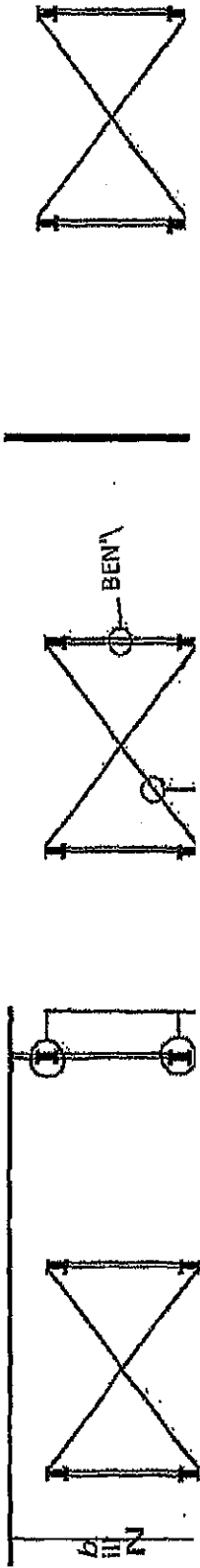

COL-UHN

UJBLE BRAC:HNET

COLUMN AND BEAM PLAN

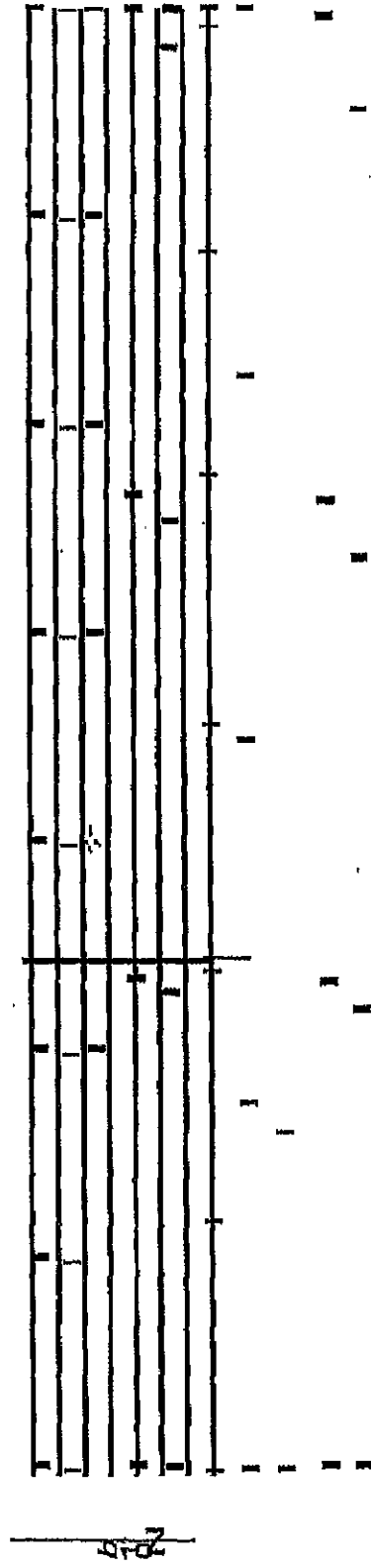



Evaluator: SHINE

GCC Bid No: GCC-FB-21-009

Bid Description: Replacement of Building 900 Metal Awning Structure

04/15/2021

May 2021

Guam Community College (GCC) is soliciting the service of a qualified contractor to replace the dilapidated awning structure located at building 900 and including (but not limited to) the following.

SCOPE OF WORK (SOW):

A. General Requirements of the Scope of Work:

The Qualified Contractor for this SOW shall:

- 1. Conduct a holistic assessment, verify existing conditions, and conduct all the necessary work for a design build concept to replace the dilapidated awning located at building 900 to include all component elements for complete functionality, operation, safety and code-compliance (i.e., civil, mechanical, infrastructure, etc.).
- 2. Provide contractual services to include at a minimum the following component elements - assessment, estimation, replacement requirements, certification, and as-build drawings
- 3. Ensure "good standings" with governing authorities having jurisdiction with the SOW (e.g., Guam Department of Public Works, Department of Revenue and Taxation, Guam Contractor's License Board, etc.) prior to commencing work related to this SOW.
- 4. When appropriate, obtain and pay requisite permits, clearances, and approvals, from all applicable government of Guam agencies.
- 5. A mandatory site visit schedule for 10:00 a.m. at the project site on Wednesday, May 19, 2021. Contact Josephine Arceo at 735-5521 if accommodative service or an additional site visit is needed.
- 6. Warranty: Qualified Contractor shall assure against defective materials and workmanship by providing a one (1) year written Certificate of Warranty. The Certificate of Warranty shall commence immediately upon GCC's explicit acceptance of the project. The Certificate of Warranty shall honor all product warranties and include the cost of all parts, workmanship, and related labor fees. Qualified Contractor must provide and honor all written product warranties.
- 7. When awarded, the Qualified Contractor shall submit a list and have all supplies and materials for GCC's explicit approval prior to their use or installation. All supplies, materials, and incidentals included in this SOW shall be new and of the most suitable grade for the purpose intended.
- 8. Qualified Contractor's employees assigned to this project shall be cleared from the Guam Sex Offender Registry and have a GCC badge clearly visible on his/her person.





① 9. The Qualified Contractor shall conform to all Occupational Safety and Health Administration (OSHA) regulations, the National Electrical Code (NEC), Environmental Protection Agency and the National Fire Protection Association (NFPA). Clean, maintain, protect work site, and newly installed work as necessary throughout the project period. Provide suitable protective covering on newly installed work when reasonably required to mitigate damage (e.g., during inclement weather) until such time the project is accepted by GCC. Before commencing work, the Qualified Contractor shall coordinate and have in place necessary provisions to protect adjacent building properties for safety, to minimize disruptions and prevent ANY potential hazards. For example, relocate contents away from immediate work area to unoccupied location as work requirements dictate.

DC ① 10. Properly dispose and recycle all waste, debris, rubbish etc. associated with the project legally and off-site. Do not allow debris to accumulate at the project site.

① 11. Take all precautions to assure that GCC's stakeholders (students, employees, and visitors) remain out of harm's way throughout the project. The Qualified Contractor shall properly block off the project site and use appropriate signage.

① 12. GCC's hours of operation is Monday through Thursday, 7:30 a.m. to 10 p.m., Friday from 7:30 a.m. to 6:00 pm, and Saturday from 7:30 a.m. to 12 p.m. GCC also recognizes Government of Guam's holidays. The Qualified Contractor's request to work on campus outside of GCC's hours of operation must be preapproved by Planning and Development Department.

① 13. The Qualified Contractor and her/his employees shall adhere to GCC's Tobacco and Betel Nut (Pugu'a) Free Policy 175:

- a. DO NOT use tobacco products while on Guam Community College property.
- b. DO NOT use electronic cigarette (e-cigs) devices while on Guam Community College property.
- c. DO NOT chew or spit pugu'a or chewing tobacco while on Guam Community College property. The Qualified Contractor and her/his employees shall adhere to Public Health and GCC's COVID19 guidelines on campus at all times;

① 14. Correct defective work to meet SOW requirements.

① 15. The project is deemed complete by the Qualified Contractor's submission of all warranties, as-built, GCC's formal inspection, and GCC's acceptance of the project for its intended use.

① 16. Submit a price proposal having an Itemized cost such that GCC may award the project based on the "...lowest, most responsive..." price proposal based on the Scope of Work and related requirements (A. General Requirements of the Scope of Work and B. Specific Requirements of the Scope of Work).



17. Qualified Contractor shall deliver a complete price proposal packet to include the following (18a-18e):

- ① a. A Narrative (required document) describing how the Qualified Contractor will address this project's SOW;
- ① b. A Critical Path Method (CPM) chart (required document) to illustrate the Qualified Contractor's timeline to complete the project within ninety (90) consecutive calendar days upon receipt of a purchase order and inclusive of the building permit process and material lead-time;
- ① c. Submission of a conceptual design illustrating the size and design of the awning.
- ① d. Submission of Bid (with required documents): one original and two complete copies; and
- ① e. Cost breakdown for:

*SEE SUBMITTED PRICE QUOTATION*

1. Building 900 Awning Bid Price Sheet:

Description of Work	Cost for Supplies, Materials, etc..	Cost for Labor	Total
a. Removal and disposal of the existing awning. (i.e. Corrugated roof sheet panels, purlins, rafters, etc...)			
b. Removal and disposal of the existing metal columns and beams			
c. Installation of new metal columns and beams (Option 1 for Black Iron and Option 2 for Galvanized)			
d. Installation of cable bracing at three (3) specific locations			
e. Installation of new Purlins, S-layer and 2'-6" overlap including all component elements			
f. Installation of new rafter system including all component elements			
g. Installation of 22 gauge thickness corrugated roof sheet panels to include roof sealant for fastener and joint protection and leak prevention.			
h. Application of oil based primer and two (2) coats final paint on corrugated roof sheet panels (top and bottom)			



**GCC Bid No:**  
**GCC-FB-21-009**

May 2021

Page 4 of 6

i. Removal and reinstallation of additional tools, equipment, infrastructure, etc... Into the new awning structure.			
Total Project Bid Price			

- ① e. Submit ALL required documents (A. General Requirements of the Scope of Work (SOW) and B. Technical Specifications of the SOW), before **June 03, 2021** to:  
 Joleen Evangelista, Procurement & Inventory Administrator  
 Materials Management Office  
 Guam Community College  
 One Sesame Street  
 Student Services and Administration Building, Room 2105  
 Mangilao, Guam 96913

18. GCC shall be indemnified for any under-estimations / oversights attributed to the Qualified Contractor's lack of due diligence or wrongful assumptions.

**B. Technical Specifications:**

1. Awning: The new awning design shall be identical to the existing awning system at building 900.

- ① a. Removal and disposal of existing metal awning to include sheet panels, purlins, rafters and all component elements;
  - ① b. Removal and disposal of existing metal columns and beams;
  - ① c. Installation of new metal columns and beams with oil-based primer and two (2) coat final paint;
  - ① d. Installation of cable bracing at 3 specific locations;
  - ① e. Installation of purlins S-layer and 2'-6" overlap;
  - ① f. Installation of rafter system;
  - ① g. Installation of 22-gauge thickness corrugated roof sheet panels
  - ① h. Installation of gutter and downspout.
  - ① i. Removal and reinstallation of additional tools, equipment, infrastructure, etc... that were a part of the original awning structure (to be determined by Program Deans, Department Chairs and Faculty);
2. The Qualified Contractor shall ensure the new awning structure shall be properly and securely integrated into the building 900 structure;
3. The Qualified Contractor shall ensure the use of only anti-corrosive fasteners, nuts, bolts, etc... and no metal to metal corrosion reactions as a result of two different metals being in contact;
- ① 4. The Qualified contractor shall ensure absolutely no leaks at any point of the new awning structure roof;
- ① 5. The Qualified Contractor shall ensure the structure is engineered to withstand maximum sustained winds of 200 miles-per hour.
6. Refer to the attached Exhibit #1

[GUAM COMMUNITY COLLEGE-BUILDING 900 METAL AWING]

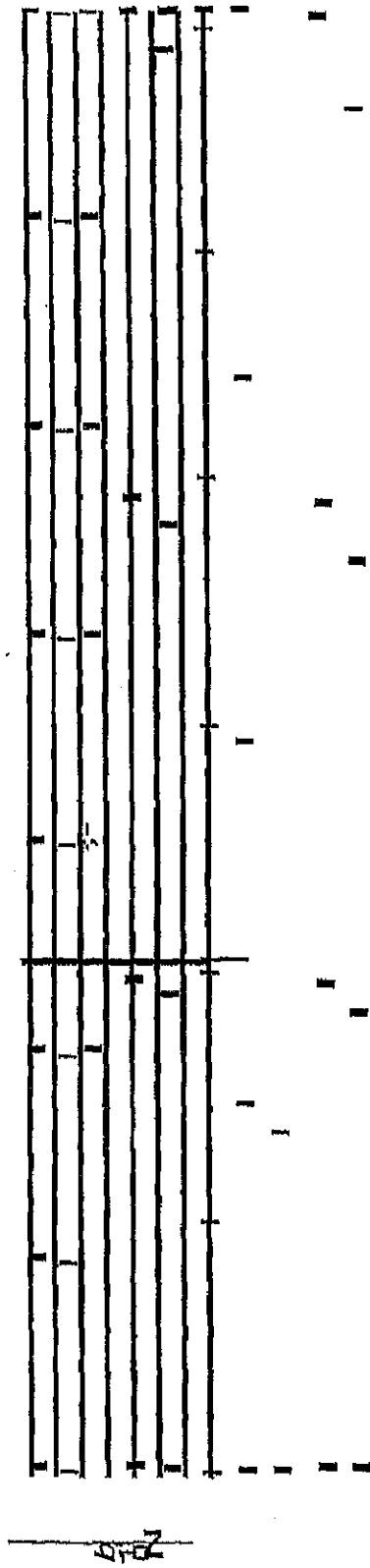
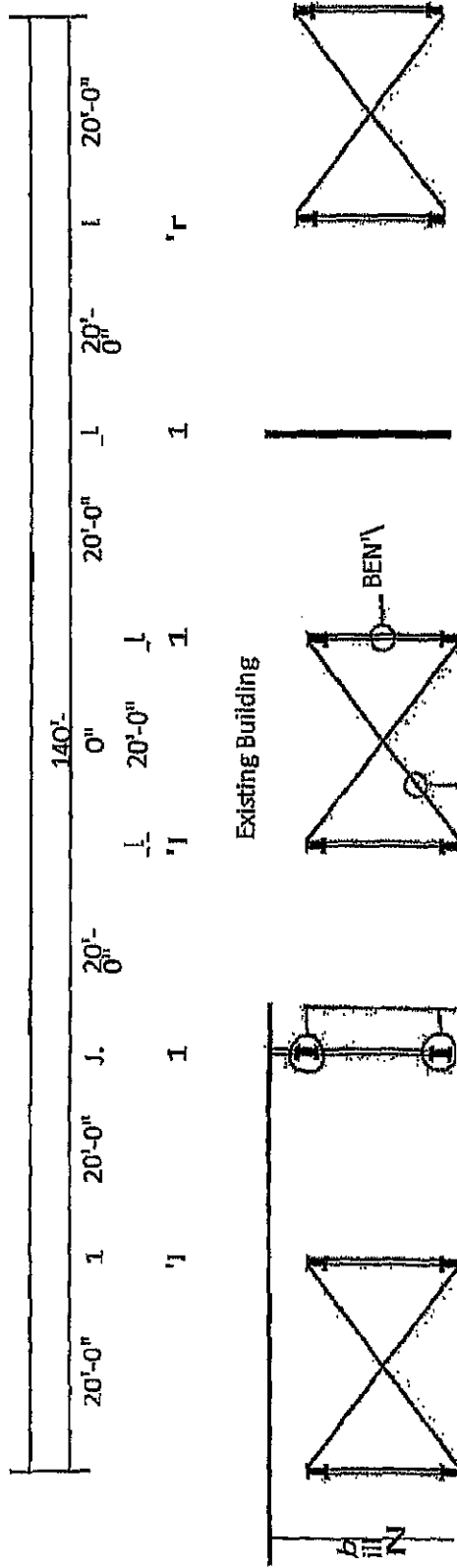

ROOF PURLIN PLAN

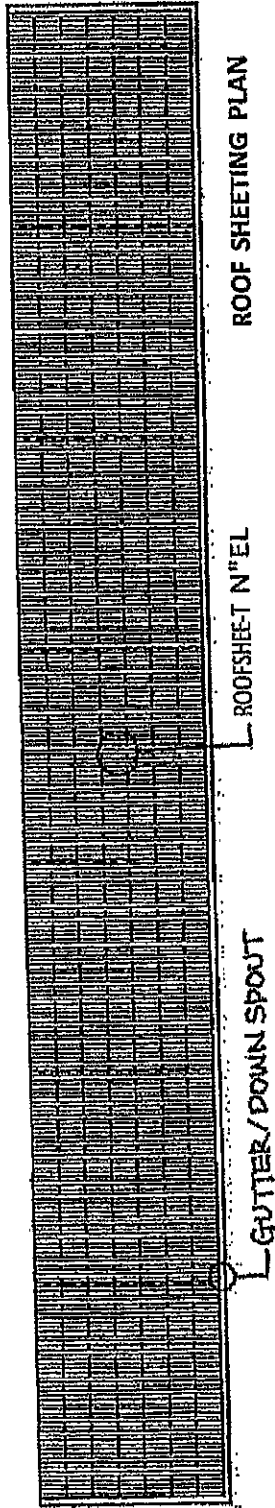

1/2"

## Joleen Evangelista

---

**From:** Joleen Evangelista <joleen.evangelista@guamcc.edu>  
**Sent:** Monday, June 21, 2021 9:20 AM  
**To:** admin@clayarchinc.com  
**Cc:** materialsmanagement@guamcc.edu; Francisco 'Kiko' Palacios (francisco.palacios1@guamcc.edu); 'Julie Ulloa-Heath'; inocencio.sanagustin@guamcc.edu  
**Subject:** Clarification request GCC-FB-21-009 Replacement of Building 900 Awning Structure

Mr. Kong,

GCC is working on the evaluation for the above bid and would like to clarify the following:

- 1) Please clarify if Clayarch will remove and reinstall existing equipment, tools, systems, infrastructure, CCTV, etc... into the new awning structure. This will be determined by GCC reps.
- 2) Please clarify if rafters are a part of the purlins phase.
- 3) Please clarify if the structure will be engineered to withstand 200 mile per hour winds.
- 4) Please clarify if Clayarch will utilize only anti-corrosive fasteners, nuts, bolts etc.. and no metal to metal corrosion reaction as a result of two different metals being in contact.

Please advise ASAP or by Tuesday, June 22, 2021 via email to: [materialsmanagement@guamcc.edu](mailto:materialsmanagement@guamcc.edu).

Thank you and Best Regards,

Joleen M. Evangelista  
Procurement & Inventory Administrator

## Joleen Evangelista

---

**From:** admin@clayarchinc.com  
**Sent:** Monday, June 21, 2021 3:58 PM  
**To:** joleen.evangelista@guamcc.edu  
**Cc:** materialsmanagement@guamcc.edu; 'Francisco 'Kiko' Palacios'; 'Julie Ulloa-Heath'; inocencio.sanagustin@guamcc.edu  
**Subject:** RE: Clarification request GCC-FB-21-009 Replacement of Building 900 Awning Structure  
**Attachments:** GCC-FB-21-009 Clarification Questions (Clayarch, Inc.).pdf

Good Afternoon. Ms. Joleen,  
Please see attached the letter of response for clarification questions.  
Please let me know if you need more information.  
Thank you and have a nice day.

Best regards,

MIN CHUL KONG



SBA 8(a), HUBZone Certified Small Business  
T (671) 646-8842 C (671) 486-8290  
[admin@clayarchinc.com](mailto:admin@clayarchinc.com)  
[mckong@clayarchinc.com](mailto:mckong@clayarchinc.com)  
[www.clayarchinc.com](http://www.clayarchinc.com)  
P.O.Box 12577 Tamuning, Guam 96931  
Suite 206 Oka Plaza No.202 Farenholt Ave.  
Tamuning, Guam 96913

---

**From:** Joleen Evangelista <joleen.evangelista@guamcc.edu>  
**Sent:** Monday, June 21, 2021 9:20 AM  
**To:** admin@clayarchinc.com  
**Cc:** materialsmanagement@guamcc.edu; Francisco 'Kiko' Palacios <francisco.palacios1@guamcc.edu>; 'Julie Ulloa-Heath' <julie.ulloaheath@guamcc.edu>; inocencio.sanagustin@guamcc.edu  
**Subject:** Clarification request GCC-FB-21-009 Replacement of Building 900 Awning Structure

Mr. Kong,

GCC is working on the evaluation for the above bid and would like to clarify the following:

- 1) Please clarify if Clayarch will remove and reinstall existing equipment, tools, systems, infrastructure, CCTV, etc... into the new awning structure. This will be determined by GCC reps.
- 2) Please clarify if rafters are a part of the purlins phase.
- 3) Please clarify if the structure will be engineered to withstand 200 mile per hour winds.
- 4) Please clarify if Clayarch will utilize only anti-corrosive fasteners, nuts, bolts etc.. and no metal to metal corrosion reaction as a result of two different metals being in contact.

Please advise ASAP or by Tuesday, June 22, 2021 via email to: [materialsmanagement@guamcc.edu](mailto:materialsmanagement@guamcc.edu).

Thank you and Best Regards,

Joleen M. Evangelista

GCC is working on the evaluation for the above bid and would like to clarify the following:

- 1) Please clarify JJ Globals One Year Written Certificate of Warranty as none was mentioned.
- 2) Please clarify JJ Globals demolition and disposal plan as none was mentioned.
- 3) Please clarify if JJ Global will complete the project within 90 Calendar Days, the provided CPM chart is unclear.
- 4) Clarify if JJ Global will utilize 22 gauge thickness corrugated roof sheet panels.
- 5) Please clarify if JJ Global will install new gutters and down spouts.
- 6) Please clarify if JJ Global will remove and reinstall existing equipment, tools, systems, infrastructure, CCTV, etc... into the new awning structure. This will be determined by GCC reps.
- 7) Please clarify if JJ Global will utilize only anti-corrosive fasteners, nuts, bolts etc.. and no metal to metal corrosion reaction as a result of two different metals being in contact.
- 8) Please clarify if the new awning structure will be engineered to withstand 200 mile per hour winds.

Please advise ASAP or by Tuesday, June 22, 2021 via email to: [materialsmanagement@guamcc.edu](mailto:materialsmanagement@guamcc.edu).

Thank you and Best Regards,

Joleen M. Evangelista

Procurement & Inventory Administrator

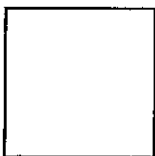

*E-mail administered by Guam Community College*



**Joleen Evangelista**

---

**From:** Aileen de Dios <aileen@jjglobal.services>  
**Sent:** Monday, June 21, 2021 9:29 AM  
**To:** Joleen Evangelista  
**Cc:** Luis E. Bustamante; materialsmanagement@guamcc.edu; Francisco 'Kiko' Palacios; Julie Uiloa-Heath; Inocencio San Agustin  
**Subject:** Re: Clarification request GCC-FB-21-009 Replacement of Building 900 Awning Structure JJ Global

Hi Ms. Joleen,

Confirming receipt of your email and I will forward it to our Engineers so they can provide the answers to your inquiries in another email.  
Thank you.

*All the best,*

**Aileen de Dios**  
General Manager  
<http://www.jjglobal.services/>  
E: aileen@jjglobal.services  
O: 671-632-1179  
F: 671-632-3550

On Mon, Jun 21, 2021 at 9:25 AM Joleen Evangelista <[joleen.evangelista@guamcc.edu](mailto:joleen.evangelista@guamcc.edu)> wrote:

Ms. De Dios and Mr. Luis Bustamante,

GCC is working on the evaluation for the above bid and would like to clarify the following:

- 1) Please clarify JJ Globals One Year Written Certificate of Warranty as none was mentioned.
- 2) Please clarify JJ Globals demolition and disposal plan as none was mentioned.
- 3) Please clarify if JJ Global will complete the project within 90 Calendar Days, the provided CPM chart is unclear.
- 4) Clarify if JJ Global will utilize 22 gauge thickness corrugated roof sheet panels.
- 5) Please clarify if JJ Global will install new gutters and down spouts.

6) Please clarify if JJ Global will remove and reinstall existing equipment, tools, systems, infrastructure, CCTV, etc... into the new awning structure. This will be determined by GCC reps.

7) Please clarify if JJ Global will utilize only anti-corrosive fasteners, nuts, bolts etc.. and no metal to metal corrosion reaction as a result of two different metals being in contact.

8) Please clarify if the new awning structure will be engineered to withstand 200 mile per hour winds.

Please advise ASAP or by Tuesday, June 22, 2021 via email to: [materialsmanagement@guamcc.edu](mailto:materialsmanagement@guamcc.edu).

Thank you and Best Regards,

Joleen M. Evangelista

Procurement & Inventory Administrator



*E-mail administered by Guam Community College*

## **Joleen Evangelista**

---

**From:** Aileen de Dios <aileen@jjglobal.services>  
**Sent:** Friday, June 25, 2021 2:57 PM  
**To:** Joleen Evangelista  
**Cc:** Kit Casin; Luis E. Bustamante; materialsmanagement@guamcc.edu; Francisco 'Kiko' Palacios; Julie Ulloa-Heath; Inocencio San Agustin; Aaron  
**Subject:** Re: Clarification request GCC-FB-21-009 Replacement of Building 900 Awning Structure JJ Global

Hi Joleen,

Please see formal responses to your inquiries:

1) Please clarify JJ Globals One Year Written Certificate of Warranty as none was mentioned.

---Yes the Certificate of Warranty is one year, per standard.

2) Please clarify JJ Globals demolition and disposal plan as none was mentioned.

---Yes we will comply as per Technical Specification on Items A & B.

---Although plan is not originally required, we will furnish upon award.

3) Please clarify if JJ Global will complete the project within 90 Calendar Days, the provided CPM chart is unclear. Will just need to input Start Days in the equation.

---CPM as shown below is clearly stipulating each line item and tentative days to finish.

Activity		Activity Description	Normal Time	Earliest Time (TE)	
start	end			Start (ES)	Finish (EF)
1	2	Assessment and evaluation of existing structure	3	0	3
1	3	Design Phase	7	0	7
3	4	Application for Building Permit & other Licenses	14	7	21
4	5	Mobilization	9	21	24
5	6	Removal of existing tools, equipment, etc. from the structure	5	24	29
5	7	Removal and disposal of the existing awning (Phase 1)	4	24	28
7	8	Removal and disposal of the existing metal columns and beams (Phase 1)	20	28	48
7	9	Removal and disposal of the existing awning (Phase 2)	4	28	32
9	10	Removal and disposal of the existing metal columns and beams (Phase 2)	10	32	42
8	9	Installation of new metal columns and beams (Phase 1)	10	38	48
10	11	Installation of new metal columns and beams (Phase 2)	10	42	52
10	12	Installation of new rafter system	7	42	49
12	13	Installation of cable bracing	5	49	54
12	14	Installation of new burlins	7	49	56
14	15	Installation of corrugated roof sheet panels	14	56	70
15	16	Application of oil based primer and paint	5	70	75

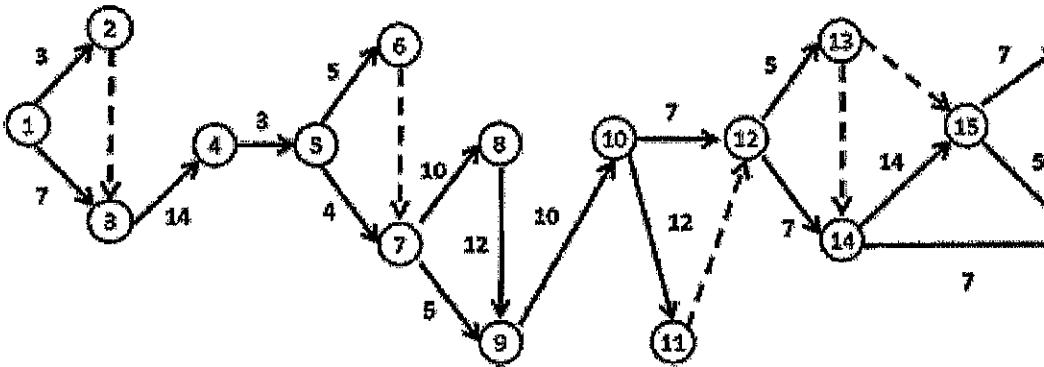

First Line Item shows progress to do from 1-2 will take about 3 (number in between arrows) Estimated Days but we are looking at finishing it "EF" 78-90 days.

Disclosure: 90 Days does not include delays due to weather or natural calamities that are beyond our control and scarcity of materials being available in our Island.

4) Clarify if JJ Global will utilize 22 gauge thickness corrugated roof sheet panels.

---Yes, it's per the required specifications.

5) Please clarify if JJ Global will install new gutters and down spouts.

---Yes, it's included in the proposal.

6) Please clarify if JJ Global will remove and reinstall existing equipment, tools, systems, infrastructure, CCTV, etc... into the new awning structure. This will be determined by GCC reps.

---Yes, kindly refer to Item I in the Bill of Quantities

7) Please clarify if JJ Global will utilize only anti-corrosive fasteners, nuts, bolts etc.. and no metal to metal corrosion reaction as a result of two different metals being in contact.

---Yes, confirmed.

8) Please clarify if the new awning structure will be engineered to withstand 200 mile per hour winds.

---Yes, it is designed to withstand the required wind load.

Thank you Joleen and let me know how else I can further assist.

*All the best,*

**Aileen de Dios**

*General Manager*

<http://www.jjglobal.services/>

*E: aileen@jjglobal.services*

*O: 671-632-1179*

*F: 671-632-3550*

On Wed, Jun 23, 2021 at 3:54 PM Joleen Evangelista <[joleen.evangelista@guamcc.edu](mailto:joleen.evangelista@guamcc.edu)> wrote:

Kit and Aileen,

Just following up again on the clarifications requested from JJ Global for the above bid. GCC needs to complete the evaluation. Please provide the information as requested in the email to [materialsmanagement@guamcc.edu](mailto:materialsmanagement@guamcc.edu).

Thank you.

Joleen M. Evangelista

Procurement & Inventory Administrator

---

**From:** Joleen Evangelista [mailto:[joleen.evangelista@guamcc.edu](mailto:joleen.evangelista@guamcc.edu)]

**Sent:** Tuesday, June 22, 2021 6:48 PM

**To:** 'Aileen de Dios' <[aileen@jjglobal.services](mailto:aileen@jjglobal.services)>

**Cc:** 'Luis E. Bustamante' <[luis.bustamante34@gmail.com](mailto:luis.bustamante34@gmail.com)>; 'materialsmanagement@guamcc.edu'

<[materialsmanagement@guamcc.edu](mailto:materialsmanagement@guamcc.edu)>; 'Francisco 'Kiko' Palacios' <[francisco.palacios1@guamcc.edu](mailto:francisco.palacios1@guamcc.edu)>; 'Julie Ulloa-

Heath' <[julie.ulloaheath@guamcc.edu](mailto:julie.ulloaheath@guamcc.edu)>; 'Inocencio San Agustin' <[inocencio.sanagustin@guamcc.edu](mailto:inocencio.sanagustin@guamcc.edu)>  
**Subject:** RE: Clarification request GCC-FB-21-009 Replacement of Building 900 Awning Structure JJ Global

Ms. De Dios,

Just following up on the clarifications requested for the above bid. Please note that the responses were due today, 6/22/21. Please provide the information as requested in the email to [materialsmanagement@guamcc.edu](mailto:materialsmanagement@guamcc.edu).

Thank you.

Joleen M. Evangelista

Procurement & Inventory Administrator

**From:** Aileen de Dios [<mailto:aileen@jjglobal.services>]

**Sent:** Monday, June 21, 2021 9:29 AM

**To:** Joleen Evangelista <[joleen.evangelista@guamcc.edu](mailto:joleen.evangelista@guamcc.edu)>

**Cc:** Luis E. Bustamante <[luis.bustamante34@gmail.com](mailto:luis.bustamante34@gmail.com)>; [materialsmanagement@guamcc.edu](mailto:materialsmanagement@guamcc.edu); Francisco 'Kiko' Palacios <[francisco.palacios1@guamcc.edu](mailto:francisco.palacios1@guamcc.edu)>; Julie Ulloa-Heath <[julie.ulloaheath@guamcc.edu](mailto:julie.ulloaheath@guamcc.edu)>; Inocencio San Agustin <[inocencio.sanagustin@guamcc.edu](mailto:inocencio.sanagustin@guamcc.edu)>

**Subject:** Re: Clarification request GCC-FB-21-009 Replacement of Building 900 Awning Structure JJ Global

Hi Ms. Joleen,

Confirming receipt of your email and I will forward it to our Engineers so they can provide the answers to your inquiries in another email.

Thank you.

*All the best,*

*Aileen de Dios*

*General Manager*

*<http://www.jjglobal.services/>*

*E: [aileen@jjglobal.services](mailto:aileen@jjglobal.services)*

*O: 671-632-1179*

*F: 671-632-3550*

On Mon, Jun 21, 2021 at 9:25 AM Joleen Evangelista <[joleen.evangelista@guamcc.edu](mailto:joleen.evangelista@guamcc.edu)> wrote:

Ms. De Dios and Mr. Luis Bustamante,

GCC is working on the evaluation for the above bid and would like to clarify the following:

- 1) Please clarify JJ Globals One Year Written Certificate of Warranty as none was mentioned.
- 2) Please clarify JJ Globals demolition and disposal plan as none was mentioned.
- 3) Please clarify if JJ Global will complete the project within 90 Calendar Days, the provided CPM chart is unclear.
- 4) Clarify if JJ Global will utilize 22 gauge thickness corrugated roof sheet panels.
- 5) Please clarify if JJ Global will install new gutters and down spouts.
- 6) Please clarify if JJ Global will remove and reinstall existing equipment, tools, systems, infrastructure, CCTV, etc... into the new awning structure. This will be determined by GCC reps.
- 7) Please clarify if JJ Global will utilize only anti-corrosive fasteners, nuts, bolts etc.. and no metal to metal corrosion reaction as a result of two different metals being in contact.
- 8) Please clarify if the new awning structure will be engineered to withstand 200 mile per hour winds.

Please advise ASAP or by Tuesday, June 22, 2021 via email to: [materialsmanagement@guamcc.edu](mailto:materialsmanagement@guamcc.edu).

Thank you and Best Regards,

Joleen M. Evangelista

Procurement & Inventory Administrator

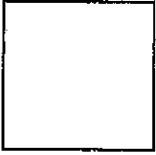

*E-mail administered by Guam Community College*



*E-mail administered by Guam Community College*



*Sent clarifications  
via email 6/21/21*

**Joleen Evangelista**

---

**From:** Francisco Palacios <francisco.palacios1@guamcc.edu>  
**Sent:** Wednesday, June 16, 2021 10:28 AM  
**To:** Joleen Evangelista  
**Cc:** Julie Ulloa-Heath; Inocencio SanAgustin  
**Subject:** GCC-FB-21-009 Clarification Questions

Hafa adai Ms. Joleen,

Below are a list of clarification questions we had for bidders for the Replacement of Bldg. 900 Awning Project(GCC-FB-21-009). Please review the questions first to see if indeed these are qualified clarification questions:

**Clayarch Inc:**

- 1) Please clarify if Clayarch will remove and reinstall existing equipment, tools, systems, infrastructure, CCTV, etc... into the new awning structure. This will be determined by GCC reps.
- 2) Please clarify if rafters are a part of the purlins phase.
- 3) Please clarify if the structure will be engineered to withstand 200 mile per hour winds.
- 4) Please clarify if Clayarch will utilize only anti-corrosive fasteners, nuts, bolts etc.. and no metal to metal corrosion reaction as a result of two different metals being in contact.

**JJ Global:**

- 1) Please clarify JJ Globals One Year Written Certificate of Warranty as none was mentioned.
- 2) Please clarify JJ Globals demolition and disposal plan as none was mentioned.
- 3) Please clarify if JJ Global will complete the project within 90 Calendar Days, the provided CPM chart is unclear.
- 4) Clarify if JJ Global will utilize 22 gauge thickness corrugated roof sheet panels.
- 5) Please clarify if JJ Global will install new gutters and down spouts
- 6) Please clarify if JJ Global will remove and reinstall existing equipment, tools, systems, infrastructure, CCTV, etc... into the new awning structure. This will be determined by GCC reps.
- 7) Please clarify if JJ Global will utilize only anti-corrosive fasteners, nuts, bolts etc.. and no metal to metal corrosion reaction as a result of two different metals being in contact.
- 8) Please clarify if the new awning structure will be engineered to the withstand 200 mile per hour winds.

--  
Francisco "Kiko" Palacios  
Guam Community College  
Planning and Development Dept.  
Sustainability and Project Coordinator  
(w)671-735-5501  
(c) 671-777-8087

"Nature is inexhaustibly sustainable if we care for it. It is our universal responsibility to pass a healthy earth onto future generations."

— Sylvia Dolson



*E-mail administered by Guam Community College*

**Memorandum**

Date: June 14, 2021

To: Francisco "Kiko" Palacios, P&D Sustainability & Project Coordinator *FCP*  
Inocencio "Shine" San Augustin, Facilities Building & Maintenance Superintendent *SH*

From: ~~Joleen Evangelista, Procurement & Inventory Administrator~~ *JW*

Subject: Evaluation of Replacement of Building 900 Metal Awning Structure

Bid No: **GCC-FB-21-009**

Bid Issued in Guam Daily Post: Thursday, May 13, 2021  
Mandatory Pre-Bid & Site Visit: Wednesday, May 19, 2021  
Bid Opening: Thursday, June 3, 2021

The following vendors showed interest in the bid (attended the Mandatory Pre-Bid Conference & site visits & purchased a bid packet):

1. Clayarch, Inc.
2. Paradise Awning
3. JJ Global

There were two (2) bids received and opened at the Bid Opening:

1. JJ Global
2. Clayarch, Inc.

Please review the bids submitted and evaluate based on the specifications set forth in the bid. Please submit the evaluations to MMO ASAP or by Monday, June 21, 2021. Please review each specification and SOW in detail to ensure the requirements are met (if not met, please provide in detail what was not met) and ensure the final evaluations are signed by all evaluators.

Thank you.

**Joleen Evangelista**

---

**From:** Aileen de Dios <aileen@jjglobal.services>  
**Sent:** Tuesday, June 8, 2021 3:41 PM  
**To:** Joleen Evangelista  
**Cc:** materialsmanagement@guamcc.edu; Luis E. Bustamante; Kit Casin; Admin Assistant; Rodalyn Gerardo  
**Subject:** Re: PRICE CORRECTION: GCC-FB-21-009 Replacement of Bldg 900 Metal Awning Structure

Hi Ms. Joleen,

Well noted. Thank you.

*All the best,*

**Aileen de Dios**  
*General Manager*  
<http://www.jjglobal.services/>  
*E: aileen@jjglobal.services*  
*O: 671-632-1179*  
*F: 671-632-3550*

On Fri, Jun 4, 2021 at 5:29 PM Joleen Evangelista <[joleen.evangelista@guamcc.edu](mailto:joleen.evangelista@guamcc.edu)> wrote:

Ms. De Dios,

Please be advised that the bid prices received from JJ Global Services cannot be changed after the Bid Opening.

Thank you.

Joleen M. Evangelista

Procurement & Inventory Administrator

**From:** Aileen de Dios [mailto:[aileen@jjglobal.services](mailto:aileen@jjglobal.services)]  
**Sent:** Thursday, June 3, 2021 6:08 PM  
**To:** Joleen Evangelista <[joleen.evangelista@guamcc.edu](mailto:joleen.evangelista@guamcc.edu)>  
**Cc:** [materialsmanagement@guamcc.edu](mailto:materialsmanagement@guamcc.edu); Luis E. Bustamante <[luis.bustamante34@gmail.com](mailto:luis.bustamante34@gmail.com)>; Kit Casin <[kit.casin@jjglobal.services](mailto:kit.casin@jjglobal.services)>; Admin Assistant <[admin@jjglobal.services](mailto:admin@jjglobal.services)>  
**Subject:** PRICE CORRECTION: GCC-FB-21-009 Replacement of Bldg 900 Metal Awning Structure

Hafa Adai Ms. Joleen and GCC Procurement Team,

This email is in pursuant to the bid opening for the above mentioned project conducted earlier today. Kindly refer to the attached for your review and consideration.

Thank you and have a blessed evening.

*All the best,*

***Aileen de Dios***

*General Manager*

<http://www.jjglobal.services/>

*E: [aileen@jjglobal.services](mailto:aileen@jjglobal.services)*

*O: 671-632-1179*

*F: 671-632-3550*



*E-mail administered by Guam Community College*

**Joleen Evangelista**

---

**From:** Aileen de Dios <aileen@jjglobal.services>  
**Sent:** Thursday, June 3, 2021 6:08 PM  
**To:** Joleen Evangelista  
**Cc:** materialsmanagement@guamcc.edu; Luis E. Bustamante; Kit Casin; Admin Assistant  
**Subject:** PRICE CORRECTION: GCC-FB-21-009 Replacement of Bldg 900 Metal Awning Structure  
**Attachments:** Price Correction Letter.pdf

Hafa Adai Ms. Joleen and GCC Procurement Team,

This email is in pursuant to the bid opening for the above mentioned project conducted earlier today. Kindly refer to the attached for your review and consideration.

Thank you and have a blessed evening.

*All the best,*

**Aileen de Dios**

*General Manager*

<http://www.jjglobal.services/>

*E: aileen@jjglobal.services*

*O: 671-632-1179*

*F: 671-632-3550*



July 2, 2021

Clayarch, Inc.  
P.O. Box 12577  
Tamuning, Guam 96931

Attention: Mr. Min Chul Kong  
Vice President

Subject: **Notice of Non-Award**

Bid No: GCC-FB-21-009  
Bid Description: Replacement of Building 900 Metal Awning Structure

Dear Mr. Kong,

This letter is to advise you that the above bid has been reviewed and evaluated and will be awarded to JJ Global Services. JJ Global Services is deemed to be the lowest, responsive and responsible bidder.

Please contact the GCC Materials Management Office to pick up your original bid bond.

GCC appreciates your time and effort in preparing for this bid and encourages you to bid in the future. Thank you for your participation and interest.

If you have any questions, please contact Joleen M. Evangelista in the GCC Materials Management Office at 735-6540 or email: [joleen.evangelista@guamcc.edu](mailto:joleen.evangelista@guamcc.edu).

Sincerely,

Mary A. Y. Okada, Ed.D.  
President

Res

cc: Materials Management

7/3/2021

Min Chul Kong  
Clayarch, Inc.



July 2, 2021

Clayarch, Inc.  
P.O. Box 12577  
Tamuning, Guam 96931

Attention: Mr. Min Chul Kong  
Vice President

Subject: **Notice of Non-Award**

Bid No: GCC-FB-21-009  
Bid Description: Replacement of Building 900 Metal Awning Structure

Dear Mr. Kong,

This letter is to advise you that the above bid has been reviewed and evaluated and will be awarded to JJ Global Services. JJ Global Services is deemed to be the lowest, responsive and responsible bidder.

Please contact the GCC Materials Management Office to pick up your original bid bond.

GCC appreciates your time and effort in preparing for this bid and encourages you to bid in the future. Thank you for your participation and interest.

If you have any questions, please contact Joleen M. Evangelista in the GCC Materials Management Office at 735-5540 or email: [joleen.evangelista@guamcc.edu](mailto:joleen.evangelista@guamcc.edu).

Sincerely,

Mary A.Y. Okada, Ed.D.  
President

*Ray*

cc: Materials Management



**Joleen Evangelista**

---

**From:** Joleen Evangelista <joleen.evangelista@guamcc.edu>  
**Sent:** Friday, July 2, 2021 5:38 PM  
**To:** admin@clayarchinc.com  
**Cc:** materialsmanagement@guamcc.edu; 'Rodalyn Gerardo'; Francisco 'Kiko' Palacios (francisco.palacios1@guamcc.edu); Huan Hosei (huan.hosei@guamcc.edu); 'Julie Ulloa-Heath'  
**Subject:** Notice of Non-Award GCC-FB-21-009 Replacement of Building 900 Metal Awning Structure  
**Attachments:** Notice of Non-Award GCC-FB-21-009.pdf

Mr. Kong,

Please see the attached Non-Award letter for GCC-FB-21-009 Replacement of Building 900 Metal Awning Structure.

Please acknowledge receipt of this Non-Award ASAP or by Tuesday, July 6, 2021 via email to: materialsmanagement@guamcc.edu.

The original letter may be picked up next week anytime between 8 am and 5 pm otherwise, we will mail it out by Thursday, July 8, 2021.

Thank you and Best Regards,

Joleen M. Evangelista  
Procurement & Inventory Administrator



July 2, 2021

To: JJ Global Services  
P.O. Box 217881 GMF  
Barrigada, Guam 96921

Attn: Mr. Luis Bustamante  
CEO

Ms. Aileen de Dios  
General Manager

Subject: Notice of Intent to Award  
GCC Bid No: **GCC-FB-21-009**  
Bid Description: Replacement of Building 900 Metal Awning Structure

Dear Mr. Bustamante and Ms. De Dios,

GCC has reviewed and evaluated your bid submission and intends to award JJ Global Services, JJ's bid is deemed the lowest, responsive and responsible. GCC intends to award Option 2: Galvanized Iron for this project in the amount of **\$163,263.84.**

Prior to providing you with the contract, JJ Global Services will need to submit the following documents:

1. The list of workers that will be assigned to this project so that GCC can clear them off the sex offender registry. Please provide their full legal name and Date of Birth.
2. Performance Bond in the amount of one-hundred percent (100%) of the contract price. The bond shall be in accordance with Item 18 of the General Terms and Conditions of this bid.
3. Certificate of Insurance showing proof of Contractor's Liability Insurance
4. Listing of subcontractors- If none, please indicate; if there are subcontractors, please provide the contractor's name and full legal name and Date of birth of the subcontractor's employees that will be assigned to this project.
5. Schedule of Values
6. Overhead and Profit Multiplier (Isolated)
7. Updated CPM Chart
8. Copy of your current Guam Contractor's license.

The project completion time is 90 consecutive calendar days upon the Notice to Proceed date.

Please provide the information and documents requested ASAP or no later than 10 days from the date of this letter. Once the requested documents are submitted, GCC will contact you to pick up the contract/PO and will schedule a post-award meeting.

GCC thanks you in participating in this bid and looks forward to working with you.

*Emmaron Rose*

7-23-21

Sincerely,

Mary A. Okada, Ed.D.  
President

*Ref*

**Joleen Evangelista**

---

**From:** Joleen Evangelista <joleen.evangelista@guamcc.edu>  
**Sent:** Friday, July 2, 2021 5:34 PM  
**To:** 'Aileen de Dios'; 'Luis E. Bustamante'  
**Cc:** Francisco 'Kiko' Palacios (francisco.palacios1@guamcc.edu); 'Julie Ulloa-Heath'; Huan Hosen (huan.hosen@guamcc.edu); 'Rodalyn Gerardo'; materialsmanagement@guamcc.edu  
**Subject:** Notice of Intent to Award GCC-FB-21-009 Replacement of Building 900 Metal Awning Structure  
**Attachments:** Notice of Intent to Award GCC-FB-21-009.pdf

Mr. Bustamante and Ms. De Dios,

Please see the attached Notice of Intent to Award letter for the GCC-FB-21-009 Replacement of Building 900 Metal Awning Structure for Option 2: Galvanized Iron.

Please review the letter and acknowledge receipt ASAP or by 5 pm Tuesday, July 6, 2021 via email to: materialsmanagement@guamcc.edu.

Please provide the required documents requested ASAP or no later than 10 days from the date of the letter.

Thank you and Best Regards,

Joleen M. Evangelista  
Procurement & Inventory Administrator

**Joleen Evangelista**

---

**From:** Joleen Evangelista <joleen.evangelista@guamcc.edu>  
**Sent:** Tuesday, July 6, 2021 9:49 AM  
**To:** 'Aileen de Dios'; 'Luis E. Bustamante'; 'Kit Casin'; 'Admin Assistant'  
**Cc:** Francisco 'Kiko' Palacios (francisco.palacios1@guamcc.edu); 'Julie Ulloa-Heath'; Huan Hosei (huan.hosei@guamcc.edu); 'Rodilyn Gerardo'; materialsmanagement@guamcc.edu  
**Subject:** Notice of Intent to Award GCC-FB-21-009 Replacement of Building 900 Metal Awning Structure  
**Attachments:** Notice of Intent to Award GCC-FB-21-009.pdf

Mr. Bustamante, Ms. Casin and JJ Global Administration:

Please note that GCC received an email return from Ms. Aileen de Dios stating that she will be out of the office from July 1, 2021 to August 2, 2021 with limited access to my email. It also indicated to send emails to Ms. Kit Casin and JJ Global Admin. for urgent matters.

Please review the letter and acknowledge receipt ASAP or by 5 pm Tuesday, July 6, 2021 via email to: materialsmanagement@guamcc.edu.

Please provide the required documents requested ASAP or no later than 10 days from the date of the letter otherwise, GCC will not be able to continue with the award.

Please let me know if you have any questions or concerns.

Thank you and Best Regards,

Joleen M. Evangelista  
Procurement & Inventory Administrator

-----Original Message-----

From: Joleen Evangelista [mailto:joleen.evangelista@guamcc.edu]  
Sent: Friday, July 2, 2021 5:34 PM  
To: 'Aileen de Dios' <aileen@jjglobal.services>; 'Luis E. Bustamante' <luis.bustamante34@gmail.com>  
Cc: Francisco 'Kiko' Palacios (francisco.palacios1@guamcc.edu) <francisco.palacios1@guamcc.edu>; 'Julie Ulloa-Heath' <julie.ulloaheath@guamcc.edu>; Huan Hosei (huan.hosei@guamcc.edu) <huan.hosei@guamcc.edu>; 'Rodilyn Gerardo' <rodilyn.gerardo@guamcc.edu>; materialsmanagement@guamcc.edu  
Subject: Notice of Intent to Award GCC-FB-21-009 Replacement of Building 900 Metal Awning Structure

Mr. Bustamante and Ms. De Dios,

Please see the attached Notice of Intent to Award letter for the GCC-FB-21-009 Replacement of Building 900 Metal Awning Structure for Option 2: Galvanized Iron.

Please review the letter and acknowledge receipt ASAP or by 5 pm Tuesday, July 6, 2021 via email to: materialsmanagement@guamcc.edu.

Please provide the required documents requested ASAP or no later than 10 days from the date of the letter.

Thank you and Best Regards,

Joleen M. Evangelista  
Procurement & Inventory Administrator

**Procurement Appeal No. OPA-PA-21-013**

# **Procurement Record**

## **Tab 11**

Date: September 23, 2021

To: MEMO TO FILE

From: Procurement & Inventory Administrator

Subject: Reason for cancellation of purchase order issued to JJ Global Services

GCC Bid No: GCC-FB-21-009

Bid Description: Replacement of Building 900 Metal Awning Structure

On September 21, 2021, GCC emailed Ms. Dios and Mr. Bustamante advised purchase order is cancelled because JJ Global services failed to sign and submit the contract picked up by Emma Reyes on August 4, 2021. The contract signed by GCC, Purchase order, and Bid Award letter was picked by Emma Reyes on August 4, 2021

**Please see the communication timeline between GCC and JJ Global representatives regarding the submission of the signed copy of contract by JJ Global Services:**

Bid Award letter dated 7/26/2021-GCC emailed on 7/27/21 & original picked up by Emma Reyes on 8/4/21

Contract signed by GCC to take effect: 7/27/21-GCC emailed on 7/27/21 & original contract picked up by Emma Reyes on 8/4/21

PO dated 7/27/21 and approved 7/28/21-GCC emailed on 7/28/21 & original PO picked up by Emma Reyes on 8/4/21

On 7/29/21, Kit Casin acknowledged receipt of the bid award, PO and contract by email- attached a letter from Mr. Bustamante requesting that the letter be rescinded and the NTP should be the date they receive the Building permit and the 90 day completion time should be affected by the delay of the non-receipt of the Building Permit.

On 8/3/21, Kit Casin emailed a letter indicating they carefully reviewed the SOW and didn't see the specifications about the Building Permit.

On 8/4/21, Procurement & Inventory Administrator referenced page 3 of 7 in the SOW where it states "Contractor's timeline to complete the project within ninety (90) consecutive calendar days upon receipt of the PO and inclusive of the building permit process and material lead-time". Also stated that the contractor may request for additional time if the permit process takes longer than what was anticipated.

On 8/6/21, Aileen de Dios emailed requesting an extension for the completion date for an additional 15 days. Stating that the design will take 2 weeks to complete and the design will be provided for GCC to approve. No extension was granted by GCC.

On 8/9/21, Virginia Tedpahago advised that Aileen de Dios will be servicing GCC on the contract. On the same day, Virginia Tedpahago advised that she followed up on the contract and was informed that the contract will be expedited via postal service to Mr. Bustamante because he was currently off-island.

On 8/25/21, Procurement & Inventory Administrator followed up on the following: 1. GCC needs the signed contract by Mr. Luis Bustamante. 2. Confirm if the drawings/plans for the project have been submitted to GCC since the time has passed. 3. Is JJ Global able to proceed with this project and carry out all the required work stated in the bid? Response due by: 8/26/21.

On 8/26/21, Aileen de Dios, after reviewing the contract, she indicated that it did not address the disclosures in their 6/25/21 email regarding unanticipated delay and delays out of their control.

On 8/30/21, Procurement & Inventory Administrator advised that the executed contract must be received by the MMO by 5:00 p.m. on 8/31/21. The request to add additional language is not approved. Noted: GCC has not received the drawings for approval.

On 9/10/21, Francisco Palacios, Sustainability and Project Coordinator received an email which included drawings from Aileen de Dios of JJ Global services.

On 9/22/21, Procurement & Inventory Administrator advised that since JJ Global has not submitted the signed contract, the PO is cancelled.

On 9/22/21, Aileen de Dios confirmed receipt of the email on the cancellation of the PO and advised that a formal response is forthcoming.

As of 9/23/21, GCC has yet to receive a formal response.

GCC would like to proceed with the cancellation of the PO and this project initially awarded to JJ Global Services and take the next step in this procurement.



**Joleen Evangelista**

---

**From:** Mary Okada <mary.okada@guamcc.edu>  
**Sent:** Wednesday, September 22, 2021 11:49 AM  
**To:** Joleen Evangelista  
**Cc:** 'Rodalyn Gerardo'  
**Subject:** procurement file

Ms. Joleen,

Please ensure that there is a document in the procurement file for Building 900 awning in the procurement file indicating the reason for the cancellation of the purchase order. It would be best to have a chronology that outlines the delay from JJ in providing documentation.

Thank you!

Mary



*E-mail administered by Guam Community College*

**Joleen Evangelista**

---

**From:** Aileen de Dios <aileen@jglobal.services>  
**Sent:** Wednesday, September 22, 2021 4:37 PM  
**To:** Joleen Evangelista  
**Cc:** Luis Bustamante; Kit Casin; Virginia Tedpahogo; Julie Ulloa-Heath; Admin Assistant; Francisco 'Kiko' Palacios; Rodalyn Gerardo; Luis E. Bustamante  
**Subject:** Re: GCC-FB-21-009 Replacement of Bldg. 900 Metal Awning Structure

Hafa Adai Ms. Joleen,

Confirming receipt of your email and our formal response forthcoming.  
Thank you.

*All the best,*

**Aileen de Dios**  
*General Manager*  
<http://www.jglobal.services/>  
*E: aileen@jglobal.services*  
*O: 671-632-1179*  
*F: 671-632-3550*

On Wed, Sep 22, 2021 at 12:27 PM Joleen Evangelista <[joleen.evangelista@guamcc.edu](mailto:joleen.evangelista@guamcc.edu)> wrote:

Ms. De Dios and Mr. Bustamante,

**Please note:** Correction to the date of when the email was sent: The date is 8/30/21 and not 9/30/21.

Please acknowledge receipt of this email ASAP or by 5:00 p.m., September 22, 2021.

Thank you and Best Regards,

Joleen M. Evangelista

Procurement & Inventory Administrator

---

**From:** Joleen Evangelista [mailto:[joleen.evangelista@guamcc.edu](mailto:joleen.evangelista@guamcc.edu)]  
**Sent:** Tuesday, September 21, 2021 5:21 PM  
**To:** 'Aileen de Dios' <[aileen@jjglobal.services](mailto:aileen@jjglobal.services)>; 'Luis Bustamante' <[luis.bustamante@jjglobal.services](mailto:luis.bustamante@jjglobal.services)>  
**Cc:** 'Kit Casin' <[kit.casin@jjglobal.services](mailto:kit.casin@jjglobal.services)>; 'Virginia Tedpahogo' <[virginia@jjglobal.services](mailto:virginia@jjglobal.services)>; 'Julie Ulloa-Heath' <[julie.ulloaheath@guamcc.edu](mailto:julie.ulloaheath@guamcc.edu)>; 'Admin Assistant' <[admin@jjglobal.services](mailto:admin@jjglobal.services)>; 'Francisco 'Kiko' Palacios' <[francisco.palacios1@guamcc.edu](mailto:francisco.palacios1@guamcc.edu)>; 'Rodalyn Gerardo' <[rodalyn.gerardo@guamcc.edu](mailto:rodalyn.gerardo@guamcc.edu)>; 'Luis E. Bustamante' <[luis.bustamante34@gmail.com](mailto:luis.bustamante34@gmail.com)>  
**Subject:** RE: GCC-FB-21-009 Replacement of Bldg. 900 Metal Awning Structure

Ms. De Dios and Mr. Bustamante,

Please advised that since JJ Global has not submitted the signed contract, the purchase order is canceled. Please note the email sent on 9/30/21 requesting for the signed contract to be submitted by August 31, 2021.

Please let me know if you have any questions.

Best Regards,

Joleen M. Evangelista

Procurement & Inventory Administrator

---

**From:** Joleen Evangelista [mailto:[joleen.evangelista@guamcc.edu](mailto:joleen.evangelista@guamcc.edu)]  
**Sent:** Monday, August 30, 2021 4:54 PM  
**To:** 'Aileen de Dios' <[aileen@jjglobal.services](mailto:aileen@jjglobal.services)>; 'Luis Bustamante' <[luis.bustamante@jjglobal.services](mailto:luis.bustamante@jjglobal.services)>  
**Cc:** 'Kit Casin' <[kit.casin@jjglobal.services](mailto:kit.casin@jjglobal.services)>; 'Virginia Tedpahogo' <[virginia@jjglobal.services](mailto:virginia@jjglobal.services)>; 'Julie Ulloa-Heath' <[julie.ulloaheath@guamcc.edu](mailto:julie.ulloaheath@guamcc.edu)>; 'Admin Assistant' <[admin@jjglobal.services](mailto:admin@jjglobal.services)>; 'Francisco 'Kiko' Palacios' <[francisco.palacios1@guamcc.edu](mailto:francisco.palacios1@guamcc.edu)>; 'Rodalyn Gerardo' <[rodalyn.gerardo@guamcc.edu](mailto:rodalyn.gerardo@guamcc.edu)>; 'Luis E. Bustamante' <[luis.bustamante34@gmail.com](mailto:luis.bustamante34@gmail.com)>  
**Subject:** GCC-FB-21-009 Replacement of Bldg. 900 Metal Awning Structure

Ms. De dios and Mr. Bustamante,

GCC is in receipt of your letter dated August 26, 2021. Please be advised that the executed contract must be received by our office by 5:00pm, CHST on August 31, 2021. The request to add additional language is not approved.

Please note, we have not received the drawings for approval.

Thank you.

Joleen M. Evangelista

Procurement & Inventory Administrator

**From:** Aileen de Dios [<mailto:aileen@jjglobal.services>]

**Sent:** Thursday, August 26, 2021 10:05 PM

**To:** Joleen Evangelista <[joleen.evangelista@guamcc.edu](mailto:joleen.evangelista@guamcc.edu)>

**Cc:** Kit Casin <[kit.casin@jjglobal.services](mailto:kit.casin@jjglobal.services)>; Virginia Tedpahogo <[virginia@jjglobal.services](mailto:virginia@jjglobal.services)>; Julie Ulloa-Heath <[julie.ulloaheath@guamcc.edu](mailto:julie.ulloaheath@guamcc.edu)>; Admin Assistant <[admin@jjglobal.services](mailto:admin@jjglobal.services)>; Francisco 'Kiko' Palacios <[francisco.palacios1@guamcc.edu](mailto:francisco.palacios1@guamcc.edu)>; Rodalyn Gerardo <[rodalyn.gerardo@guamcc.edu](mailto:rodalyn.gerardo@guamcc.edu)>; Luis E. Bustamante <[luis.bustamante34@gmail.com](mailto:luis.bustamante34@gmail.com)>

**Subject:** Re: Replacement of Bldg. 900 Metal Awning Structure

Hafa Adai Ms Joleen,

Pls see attached letter pursuant to the signing of the contract.

*All the best,*

***Aileen de Dios***

*General Manager*

<http://www.jjglobal.services/>

E: [ajleen@jjglobal.services](mailto:ajleen@jjglobal.services)

O: 671-632-1179

F: 671-632-3550

On Wed, Aug 25, 2021 at 2:01 PM Joleen Evangelista <[joleen.evangelista@guamcc.edu](mailto:joleen.evangelista@guamcc.edu)> wrote:

Dear Mr. Bustamante and the JJ Global Services Team:

I would like to follow up on the following for the items for the above project:

1. GCC needs the signed original contract by Mr. Luis Bustamante. On August 9, 2021, GCC was informed that he was off-island and that the signed contract would be submitted however, as of 8/25/2021 GCC has not received the signed contract. GCC Materials management Office has called to follow up by phone and in person however, it is Ms. Casin did not know status of the signed contract. The PO was acknowledged and received by JJ Global since 8/4/2021. Please note that Mr. Bustamante attended an on-site (informal post award) meeting on August 11, 2021 with additional JJ Global employees however, the signed contract was not submitted.
2. Please confirm if the drawings/plans for the project have been submitted to GCC Facilities Office (Dr. Julie Ulloa-Heath and Mr. Kiko Palacios). There was a request for additional time to submit the drawings to GCC for approval so that JJ Global can obtain the permit to start the project. Please confirm if the drawings are ready for submission to GCC since the additional 15 days to submit the drawings has passed.
3. Is JJ Global able to proceed with this project and carry out all the required work to complete as stated in the bid? Please advise.

Please provide a response to this request ASAP or by Thursday, August 26, 2021 via email to: [materialsmanagement@guamcc.edu](mailto:materialsmanagement@guamcc.edu) <<mailto:materialsmanagement@guamcc.edu>> .

Thank you and Regards,

Joleen M. Evangelista

Procurement & Inventory Administrator

From: Joleen Evangelista [mailto:[joleen.evangelista@guamcc.edu](mailto:joleen.evangelista@guamcc.edu)]  
Sent: Wednesday, August 4, 2021 4:17 PM  
To: 'Kit Casin' <[kit.casin@jjglobal.services](mailto:kit.casin@jjglobal.services)>  
Cc: 'Julie Ulloa-Heath' <[julie.ulloaheath@guamcc.edu](mailto:julie.ulloaheath@guamcc.edu)>; 'Aileen de Dios' <[aileen@jjglobal.services](mailto:aileen@jjglobal.services)>; 'Luis E. Bustamante' <[luis.bustamante34@gmail.com](mailto:luis.bustamante34@gmail.com)>; 'Virginia Tedpahogo' <[virginia@jjglobal.services](mailto:virginia@jjglobal.services)>; 'Florenda Miranda' <[flor@jjglobal.services](mailto:flor@jjglobal.services)>; 'Admin Assistant' <[admin@jjglobal.services](mailto:admin@jjglobal.services)>  
Subject: RE: Replacement of Bldg. 900 Metal Awning Structure

Kit,

Please see page 3 of 7 in the SOW titled: Bid Description Replacement of Building 900 Metal Awning Structure GCC Bid No: GCC-FB-21-009.

Item Number 18. B. states "Contractor's timeline to complete the project within ninety (90) consecutive calendar days upon receipt of PO and inclusive of the building permit process and material lead-time". You may request for an extension if the permit process takes longer than what you anticipated when you submitted your bid. JJ Global may submit a request in writing asking for an extension because of the time it took to obtain a permit.

Thank you and Best Regards,

Joleen M. Evangelista

Procurement & Inventory Administrator

From: Kit Casin [mailto:[kit.casin@jjglobal.services](mailto:kit.casin@jjglobal.services)]  
Sent: Tuesday, August 3, 2021 4:25 PM  
To: Joleen Evangelista <[joleen.evangelista@guamcc.edu](mailto:joleen.evangelista@guamcc.edu)>  
<<mailto:joleen.evangelista@guamcc.edu>> >  
Cc: Julie Ulloa-Heath <[julie.ulloaheath@guamcc.edu](mailto:julie.ulloaheath@guamcc.edu)>  
<<mailto:julie.ulloaheath@guamcc.edu>> >; Aileen de Dios  
<[aileen@jjglobal.services](mailto:aileen@jjglobal.services) <<mailto:aileen@jjglobal.services>> >; Luis E.  
Bustamante <[luis.bustamante34@gmail.com](mailto:luis.bustamante34@gmail.com) <<mailto:luis.bustamante34@gmail.com>>  
>; Virginia Tedpahogo <[virginia@jjglobal.services](mailto:virginia@jjglobal.services)>  
<<mailto:virginia@jjglobal.services>> >; Florenda Miranda  
<[flor@jjglobal.services](mailto:flor@jjglobal.services) <<mailto:flor@jjglobal.services>> >; Admin Assistant  
<[admin@jjglobal.services](mailto:admin@jjglobal.services) <<mailto:admin@jjglobal.services>> >  
Subject: Replacement of Bldg. 900 Metal Awning Structure

Hafa Adai Mr. Joleen,

I hope this email finds you well.

Kindly find attached Replacement of Bldg. 900 Metal Awning Structure of contract for your reference.

Please acknowledge receipt of this email.

Should you need further assistance, please do not hesitate to contact us.

Thank you

Best Regards,

Kit Casin

Executive Secretary

Services

PO Box 217881

GMF Barrigada GU 96921

Tel # 671-633-2603

email: kit.casin <<mailto:kit.casin@jjglobal.services>> @jjglobal.services

<<http://www.jjglobal.services/>> <http://www.jjglobal.services/>

--

E-mail administered by Guam Community College



*E-mail administered by Guam Community College*



**Joleen Evangelista**

---

**From:** Joleen Evangelista <joleen.evangelista@guamcc.edu>  
**Sent:** Wednesday, September 22, 2021 12:27 PM  
**To:** 'Aileen de Dios'; 'Luis Bustamante'  
**Cc:** 'Kit Casin'; 'Virginia Tedpahogo'; 'Julie Ulloa-Heath'; 'Admin Assistant'; 'Francisco 'Kiko' Palacios'; 'Rodaly Gerardo'; 'Luis E. Bustamante'  
**Subject:** RE: GCC-FB-21-009 Replacement of Bldg. 900 Metal Awning Structure

Ms. De Dios and Mr. Bustamante,

**Please note:** Correction to the date of when the email was sent: The date is 8/30/21 and not 9/30/21.

Please acknowledge receipt of this email ASAP or by 5:00 p.m., September 22, 2021.

Thank you and Best Regards,

Joleen M. Evangelista  
Procurement & Inventory Administrator

---

**From:** Joleen Evangelista [mailto:joleen.evangelista@guamcc.edu]  
**Sent:** Tuesday, September 21, 2021 5:21 PM  
**To:** 'Aileen de Dios' <aileen@jjglobal.services>; 'Luis Bustamante' <luis.bustamante@jjglobal.services>  
**Cc:** 'Kit Casin' <kit.casin@jjglobal.services>; 'Virginia Tedpahogo' <virginia@jjglobal.services>; 'Julie Ulloa-Heath' <julie.ulloaheath@guamcc.edu>; 'Admin Assistant' <admin@jjglobal.services>; 'Francisco 'Kiko' Palacios' <francisco.palacios1@guamcc.edu>; 'Rodaly Gerardo' <rodalyn.gerardo@guamcc.edu>; 'Luis E. Bustamante' <luis.bustamante34@gmail.com>  
**Subject:** RE: GCC-FB-21-009 Replacement of Bldg. 900 Metal Awning Structure

Ms. De Dios and Mr. Bustamante,

Please advised that since JJ Global has not submitted the signed contract, the purchase order is canceled. Please note the email sent on 9/30/21 requesting for the signed contract to be submitted by August 31, 2021.

Please let me know if you have any questions.

Best Regards,

Joleen M. Evangelista  
Procurement & Inventory Administrator

---

**From:** Joleen Evangelista [mailto:joleen.evangelista@guamcc.edu]  
**Sent:** Monday, August 30, 2021 4:54 PM  
**To:** 'Aileen de Dios' <aileen@jjglobal.services>; 'Luis Bustamante' <luis.bustamante@jjglobal.services>  
**Cc:** 'Kit Casin' <kit.casin@jjglobal.services>; 'Virginia Tedpahogo' <virginia@jjglobal.services>; 'Julie Ulloa-Heath' <julie.ulloaheath@guamcc.edu>; 'Admin Assistant' <admin@jjglobal.services>; 'Francisco 'Kiko' Palacios' <francisco.palacios1@guamcc.edu>; 'Rodaly Gerardo' <rodalyn.gerardo@guamcc.edu>; 'Luis E. Bustamante'

<luis.bustamante34@gmail.com>

Subject: GCC-FB-21-009 Replacement of Bldg. 900 Metal Awning Structure

Ms. De dios and Mr. Bustamante,

GCC is in receipt of your letter dated August 26, 2021. Please be advised that the executed contract must be received by our office by 5:00pm, CHST on August 31, 2021. The request to add additional language is not approved.

Please note, we have not received the drawings for approval.

Thank you.

Joleen M. Evangelista  
Procurement & Inventory Administrator

**From:** Aileen de Dios [mailto:[aileen@jjglobal.services](mailto:aileen@jjglobal.services)]

**Sent:** Thursday, August 26, 2021 10:05 PM

**To:** Joleen Evangelista <[joleen.evangelista@guamcc.edu](mailto:joleen.evangelista@guamcc.edu)>

**Cc:** Kit Casin <[kit.casin@jjglobal.services](mailto:kit.casin@jjglobal.services)>; Virginia Tedpahogo <[virginia@jjglobal.services](mailto:virginia@jjglobal.services)>; Julie Ulloa-Heath <[julie.ulloaheath@guamcc.edu](mailto:julie.ulloaheath@guamcc.edu)>; Admin Assistant <[admin@jjglobal.services](mailto:admin@jjglobal.services)>; Francisco 'Kiko' Palacios <[francisco.palacios1@guamcc.edu](mailto:francisco.palacios1@guamcc.edu)>; Rodalyn Gerardo <[rodalyn.gerardo@guamcc.edu](mailto:rodalyn.gerardo@guamcc.edu)>; Luis E. Bustamante <[luis.bustamante34@gmail.com](mailto:luis.bustamante34@gmail.com)>

**Subject:** Re: Replacement of Bldg. 900 Metal Awning Structure

Hafa Adai Ms Joleen,

Pls see attached letter pursuant to the signing of the contract.

*All the best,*

**Aileen de Dios**

**General Manager**

<http://www.jjglobal.services/>

*E: [aileen@jjglobal.services](mailto:aileen@jjglobal.services)*

*O: 671-632-1179*

*F: 671-632-3550*

On Wed, Aug 25, 2021 at 2:01 PM Joleen Evangelista <[joleen.evangelista@guamcc.edu](mailto:joleen.evangelista@guamcc.edu)> wrote:

Dear Mr. Bustamante and the JJ Global Services Team:

I would like to follow up on the following for the items for the above project:

1. GCC needs the signed original contract by Mr. Luis Bustamante. On August 9, 2021, GCC was informed that he was off-island and that the signed

contract would be submitted however, as of 8/25/2021 GCC has not received the signed contract. GCC Materials management Office has called to follow up by phone and in person however, it is Ms. Casin did not know status of the signed contract. The PO was acknowledged and received by JJ Global since 8/4/2021. Please note that Mr. Bustamante attended an on-site (informal post award) meeting on August 11, 2021 with additional JJ Global employees however, the signed contract was not submitted.

2. Please confirm if the drawings/plans for the project have been submitted to GCC Facilities Office (Dr. Julie Ulloa-Heath and Mr. Kiko Palacios). There was a request for additional time to submit the drawings to GCC for approval so that JJ Global can obtain the permit to start the project. Please confirm if the drawings are ready for submission to GCC since the additional 15 days to submit the drawings has passed.

3. Is JJ Global able to proceed with this project and carry out all the required work to complete as stated in the bid? Please advise.

Please provide a response to this request ASAP or by Thursday, August 26, 2021 via email to: [materialsmanagement@guamcc.edu](mailto:materialsmanagement@guamcc.edu) <<mailto:materialsmanagement@guamcc.edu>> .

Thank you and Regards,

Joleen M. Evangelista

Procurement & Inventory Administrator

From: Joleen Evangelista [<mailto:joleen.evangelista@guamcc.edu>]  
Sent: Wednesday, August 4, 2021 4:17 PM  
To: 'Kit Casin' <[kit.casin@jjglobal.services](mailto:kit.casin@jjglobal.services)>  
Cc: 'Julie Ulloa-Heath' <[julie.ulloaheath@guamcc.edu](mailto:julie.ulloaheath@guamcc.edu)>; 'Aileen de Dios' <[aileen@jjglobal.services](mailto:aileen@jjglobal.services)>; 'Luis E. Bustamante' <[luis.bustamante34@gmail.com](mailto:luis.bustamante34@gmail.com)>; 'Virginia Tedpahogo' <[virginia@jjglobal.services](mailto:virginia@jjglobal.services)>; 'Florenda Miranda' <[flor@jjglobal.services](mailto:flor@jjglobal.services)>;

'Admin Assistant' <[admin@jjglobal.services](mailto:admin@jjglobal.services)>  
Subject: RE: Replacement of Bldg. 900 Metal Awning Structure

Kit,

Please see page 3 of 7 in the SOW titled: Bid Description Replacement of Building 900 Metal Awning Structure GCC Bid No: GCC-FB-21-009.

Item Number 18. B. states "Contractor's timeline to complete the project within ninety (90) consecutive calendar days upon receipt of PO and inclusive of the building permit process and material lead-time". You may request for an extension if the permit process takes longer than what you anticipated when you submitted your bid. JJ Global may submit a request in writing asking for an extension because of the time it took to obtain a permit.

Thank you and Best Regards,

Joleen M. Evangelista

Procurement & Inventory Administrator

From: Kit Casin [<mailto:kit.casin@jjglobal.services>]  
Sent: Tuesday, August 3, 2021 4:25 PM  
To: Joleen Evangelista <[joleen.evangelista@guamcc.edu](mailto:joleen.evangelista@guamcc.edu)>  
<<mailto:joleen.evangelista@guamcc.edu>> >  
Cc: Julie Ulloa-Heath <[julie.ulloaheath@guamcc.edu](mailto:julie.ulloaheath@guamcc.edu)>  
<<mailto:julie.ulloaheath@guamcc.edu>> >; Aileen de Dios  
<[aileen@jjglobal.services](mailto:aileen@jjglobal.services) <<mailto:aileen@jjglobal.services>> >; Luis E.  
Bustamante <[luis.bustamante34@gmail.com](mailto:luis.bustamante34@gmail.com) <<mailto:luis.bustamante34@gmail.com>>  
>; Virginia Tedpahogo <[virginia@jjglobal.services](mailto:virginia@jjglobal.services)>  
<<mailto:virginia@jjglobal.services>> >; Florenda Miranda  
<[flor@jjglobal.services](mailto:flor@jjglobal.services) <<mailto:flor@jjglobal.services>> >; Admin Assistant  
<[admin@jjglobal.services](mailto:admin@jjglobal.services) <<mailto:admin@jjglobal.services>> >  
Subject: Replacement of Bldg. 900 Metal Awning Structure

Hafa Adai Mr. Joleen,

I hope this email finds you well.

Kindly find attached Replacement of Bldg. 900 Metal Awning Structure of contract for your reference.

Please acknowledge receipt of this email.

Should you need further assistance, please do not hesitate to contact us.

Thank you

Best Regards,

Kit Casin

Executive Secretary

Services

PO Box 217881

GMF Barrigada GU 96921

Tel # 671-633-2603

email: kit.casin <<mailto:kit.casin@jjglobal.services>> @jjglobal.services

<<http://www.jjglobal.services/>> <http://www.jjglobal.services/>

|\_E-mail administered by Guam Community College\_

## Joleen Evangelista

---

**From:** Mary Okada <mary.okada@guamcc.edu>  
**Sent:** Tuesday, September 21, 2021 2:34 PM  
**To:** Joleen Evangelista  
**Cc:** Julie Ulloa-Heath; Rodalyn Gerardo  
**Subject:** Re: GUAM AWNING TITLE BLOCK REVISION GCC-FB-21-009

Please advise them that since they did not submit the signed contract, the purchase order is canceled.

Mary

---

**From:** Joleen Evangelista <joleen.evangelista@guamcc.edu>  
**Date:** Tuesday, September 14, 2021 at 4:40 AM  
**To:** Mary Okada <mary.okada@guamcc.edu>  
**Cc:** Julie Ulloa-Heath <julie.ulloaheath@guamcc.edu>, Rodalyn Gerardo <rodalyn.gerardo@guamcc.edu>  
**Subject:** Re: GUAM AWNING TITLE BLOCK REVISION GCC-FB-21-009

Mary,

No. We still have not received the signed contract from JJ Global.

Thanks,

Joleen

On Mon, Sep 13, 2021 at 10:02 PM Mary Okada <mary.okada@guamcc.edu> wrote:

Please confirm whether we received the signed contract.

Mary

---

**From:** Joleen Evangelista <joleen.evangelista@guamcc.edu>  
**Reply-To:** <joleen.evangelista@guamcc.edu>  
**Date:** Monday, September 13, 2021 at 4:12 PM  
**To:** <mary.okada@guamcc.edu>  
**Cc:** 'Julie Ulloa-Heath' <julie.ulloaheath@guamcc.edu>, 'Rodalyn Gerardo' <rodalyn.gerardo@guamcc.edu>  
**Subject:** FW: GUAM AWNING TITLE BLOCK REVISION GCC-FB-21-009

Mary,

Please see the attached drawing provided by JJ Global to Kiko via email. Please advise on how to proceed.

Thanks,

Joleen

**From:** Francisco Palacios [mailto:[francisco.palacios1@guamcc.edu](mailto:francisco.palacios1@guamcc.edu)]  
**Sent:** Monday, September 13, 2021 10:03 AM  
**To:** Joleen Evangelista <[joleen.evangelista@guamcc.edu](mailto:joleen.evangelista@guamcc.edu)>  
**Subject:** Fwd: GUAM AWNING TITLE BLOCK REVISION

Ms. Joleen,

JJ Global sent me their "draft" official drawing (bldg. 900 Awning) for review, however, Dr. Julie had told me not to respond and instead forward to you for communication with JJ Global. Please see message and submitted documentation. Please let me know how you want to proceed.

Best,

Kiko

----- Forwarded message -----

**From:** Aileen de Dios <[aileen@jjglobal.services](mailto:aileen@jjglobal.services)>  
**Date:** Fri, Sep 10, 2021 at 2:41 PM  
**Subject:** Fwd: GUAM AWNING TITLE BLOCK REVISION  
**To:** Francisco 'Kiko' Palacios <[francisco.palacios1@guamcc.edu](mailto:francisco.palacios1@guamcc.edu)>  
**Cc:** Luis E. Bustamante <[luis.bustamante34@gmail.com](mailto:luis.bustamante34@gmail.com)>, Aaron <[aaronburger@outlook.com](mailto:aaronburger@outlook.com)>, Admin Assistant <[admin@jjglobal.services](mailto:admin@jjglobal.services)>

HI Kiko,



Please see attached document for your perusal. Hoping for your quick assistance and approval.

*All the best,*

**Aileen de Dios**

*General Manager*

<http://www.ijglobal.services/>

*E: aileen@ijglobal.services*

*O: 671-632-1179*

*F: 671-632-3550*

----- Forwarded message -----

From: **mcd architecture** <[mcdarchitects1991@gmail.com](mailto:mcdarchitects1991@gmail.com)>

Date: Thu, Sep 9, 2021 at 5:02 PM

Subject: GUAM AWNING TITLE BLOCK REVISION

To: <[aaronburger@outlook.com](mailto:aaronburger@outlook.com)>

Cc: <[aileen@ijglobal.services](mailto:aileen@ijglobal.services)>

Hi Sir Aaron,

Sending you the revised title block of the structural plans. Kindly check if there are more corrections.

Regards,

**Luis Paulo B. Bibat**

Project Architect

## MC Dacanay Architectural Design

Address: Fillinvest East Homes, Calinta, Rizal

Landline: 8 645-0003 | 8 645-1983

Mobile: +639174058798

[www.mcddesign.com.ph](http://www.mcddesign.com.ph)

**Disclaimer notice:**

The information contained in this email and any attachment may be legally privileged and confidential. If you are not an intended recipient, you are hereby notified that any dissemination, distribution or copying of this email is strictly prohibited. If you have received this email in error, please notify the sender and permanently delete this email and any attachment immediately. You should not retain, copy or use this email or any attachment for any purpose, nor disclose all or any part of the contents to any person. The information included with this electronic mail communication is not being transmitted by secure means. M.C. Dacanay Architectural Design and its affiliates have no responsibility for unauthorized access and/or alteration to this communication, nor any consequence based on or arising from your use of information that may have been accessed or altered by any person.

--

Francisco "Kiko" Palacios

Guam Community College

Planning and Development Dept.

Sustainability and Project Coordinator

(w)671-735-5501

(c) 671-777-8087

"Nature is inexhaustibly sustainable if we care for it. It is our universal responsibility to pass a healthy earth onto future generations."

— Sylvia Dolson

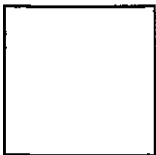

*E-mail administered by Guam Community College*

**Error! Filename not specified.**

*E-mail administered by Guam Community College*



*E-mail administered by Guam Community College*

Joleen M. Evangelista  
Procurement & Inventory Administrator

phone: 671-735-5540  
fax: 671-734-5238  
email: [joleen.evangelista@guamcc.edu](mailto:joleen.evangelista@guamcc.edu)



*E-mail administered by Guam Community College*



*E-mail administered by Guam Community College*

**A. GENERAL NOTES**

1. GENERAL NOTES AND SPECIAL STRUCTURAL DETAILS SHALL APPLY TO ALL DIMENSIONS UNLESS OTHERWISE SHOWN OR NOTED.
2. FEATURES OF CONSTRUCTION SHOWN ARE TYPICAL AND SHALL APPLY GENERALLY UNLESS OTHERWISE SPECIFIED FOR SPECIAL CONDITIONS. SMOOTH TYPICAL DETAILS IS REQUIRED TO MEET SPECIAL CONDITIONS.
3. THE CONTRACTOR SHALL EXAMINE THE DRAWINGS AND SHALL NOTIFY THE ARCHITECT/ENGINEER OF ANY DISCREPANCIES HE MAY FIND BEFORE PROCEEDING WITH THE WORK OR BEFORE CONSTRUCTION.
4. IT SHALL BE THE CONTRACTOR'S RESPONSIBILITY TO PROVIDE ADEQUATE DRAINAGE AND PROTECT THE STRUCTURE FOR ALL WEATHER THAT MAY BE REQUIRED DURING CONSTRUCTION.
5. THE CONTRACTOR SHALL FOLD WORK'S END DIMENSIONS, ELEVATIONS, ETC., NECESSARY FOR THE PROPER CONSTRUCTION AND COMPLETION OF THE WORK PORTIONS OF THE WORK TO THE EXACT WORK. THE CONTRACTOR SHALL MAKE ALL NECESSARILY NECESSARY FOR FABRICATION AND ERECTION OF STRUCTURAL MEMBERS. ANY DISCREPANCY SHALL BE IMMEDIATELY BROUGHT TO THE ATTENTION OF THE ARCHITECT.
6. THE CONTRACTOR WILL BE RESPONSIBLE FOR THE COMBINATION OF WORK AMONG THE VARIOUS TRADES AS NECESSARY TO AVOID CONFLICTS AND TO INSURE THE INSTALLATION OF ALL WORK WITHIN THE AVAILABLE SPACE.
7. DO NOT SCALE DRAWINGS. CALLED-OUT DIMENSIONS AND FINISHED WORK REQUIREMENTS SHALL BE SHOWN OVER UNCALLED DIMENSIONS. ALL DIMENSIONS ARE IN UNLESS OTHERWISE SPECIFIED.
8. SPECIAL NOTES: DIMENSIONS INDICATED ON THE STRUCTURAL DRAWINGS SHALL BE COORDINATED WITH THE ARCHITECTURAL DRAWINGS. ARCHITECTURAL DIMENSIONS SHALL BE USED TO DEFINE THE COORDINATION, DEVIATIONS, DIMENSIONS, SLOPES, ETC.
9. ALL MATERIALS AND WORKMANSHIP SHALL CONFORM TO THE LATEST APPLICABLE STANDARDS OR SPECIFICATIONS. ALL WORK SHALL CONFORM WITH THE BEST PRACTICE PREVALENT IN THE VARIOUS TRADES.
10. INSPECTION - ALL CONSTRUCTION AND WORKMANSHIP SHALL BE SUBJECT TO INSPECTION, EXAMINATION AND TESTING BY THE ENGINEER/ARCHITECT. THE ENGINEER/ARCHITECT SHALL HAVE THE RIGHT TO REQUEST SUFFICIENT MATERIALS AND WORKMANSHIP OR BEFORE ITS CONNECTION.

**B. REINFORCED CONCRETE NOTES**

**SCHEDULE OF STRUCTURAL CONCRETE 28-DAY COMPRESSIVE STRENGTH AND TYPES**

LOCATION	STRUCTURAL ELEMENTS	28-DAY COMPRESSIVE STRENGTH	CONCRETE TYPE	MINIMUM SLAB THICKNESS
FOUNDATION	FOUNDATION	3000 psi	100 PCF	#1(130mm)
	PIEDIMENTAL	3000 psi	100 PCF	#1(130mm)
GROUND FLOOR	SLAB ON GRADE	3000 psi	100 PCF	#1(130mm)

**SCHEDULE OF CONCRETE AGGREGATES**

ITEMS	AGGREGATE SIZE
FOUNDATION	3/4" (19 mm)
PIEDIMENTAL	3/4" (19 mm)
SLAB ON GRADE	1" (25 mm)

**SCHEDULE OF REINFORCING BARS**

DIAMETER OF BARS	GRADE (fy)	A. STEEL
#10 AND SMALLER	GRADE 40 (42000psi)	A101/A1011 (HOT ROLLED)

**C. FORMWORKS**

1. FORMS SHALL BE PROVIDED FOR ALL CONCRETE INDICATED UNLESS SPECIFIED OTHERWISE. FORMS SHALL BE SET TRUE TO LINE AND GRADE AND MAINTAINED SO AS TO INSURE COMPLIANT WORK WITHIN THE ALLOWABLE TOLERANCES SPECIFIED AND SHALL BE WORKMANLY.

**D. STRUCTURAL STEEL**

1. ALL STRUCTURAL STEEL SECTIONS SHALL CONFORM TO THE AISC MANUAL OF STEEL CONSTRUCTION, 13TH EDITION.
2. UNLESS OTHERWISE NOTED, ALL MATERIALS SHALL BE IN ACCORDANCE WITH THE FOLLOWING AISC SPECIFICATIONS:
  - STRUCTURAL STEEL: AISC 360
  - ANCHOR BOLTS: AISC 308
  - PLATES, TUBES: AISC 360
  - WELDS: AWS D1.1
3. ALL WELDS SHALL BE IN ACCORDANCE WITH AWS D1.1 CODE BOOK FOR STEEL WELDS, UNLESS OTHERWISE NOTED. PROVIDE CORN. UN. WELD FILL METERS FOR WELD REPAIRS.
4. ALL CONNECTIONS SHALL BE RIGID-FRAME, UNLESS OTHERWISE SPECIFIED. ALL CONNECTIONS SHALL HAVE SUFFICIENT RIGIDITY TO MAINTAIN FULLY DEVELOPED THE ORIGINAL ANGLES BETWEEN INTERSECTING MEMBERS.
5. ALL SOLD FORMER STEEL REINFORCING MEMBERS, THEIR BENDS, FABRICATION SHALL CONFORM TO THE SPECIFICATIONS FOR THE DESIGN OF SOLD FORMED STEEL REINFORCING MEMBERS, PART OF THE AISC.
6. UNLESS OTHERWISE NOTED, ALL STRUCTURAL STEEL PERMANENTLY EXPOSED TO WEAR SHALL BE PAINTED WITH STANDARD PAINT MATERIALS AND COATING FOR WEAR PROTECTION.

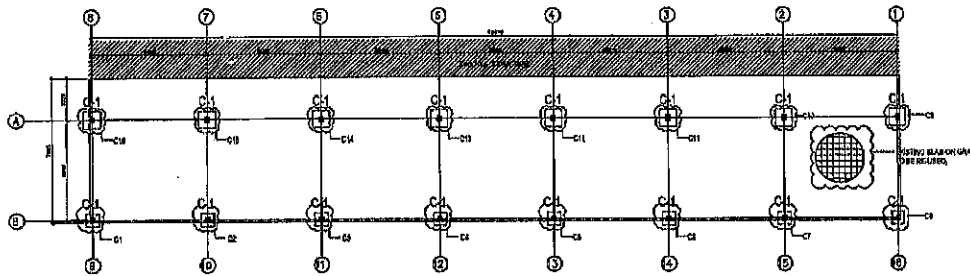

COLUMN NUMBER	BEAM NUMBER	WALL BEAM NO.
C1	BEAM	WALL BEAM NO.
C2	BEAM	WALL BEAM NO.
C3	L	J
C4	E	J
C5	K	J
C6	BEAM	WALL BEAM NO.
C7	BEAM	WALL BEAM NO.
C8	L	WALL BEAM NO.
C9	K	WALL BEAM NO.
C10	BEAM	WALL BEAM NO.
C11	BEAM	WALL BEAM NO.
C12	BEAM	WALL BEAM NO.
C13	BEAM	WALL BEAM NO.
C14	BEAM	WALL BEAM NO.
C15	BEAM	WALL BEAM NO.
C16	BEAM	WALL BEAM NO.
C17	BEAM	WALL BEAM NO.
C18	BEAM	WALL BEAM NO.

**FOUNDATION PLAN**



PROJECT NO.	100-10-21-001	PROJECT TITLE	REPLACEMENT OF BUILDING AND METAL FRAME STRUCTURE	DATE	1/20/2020	DESIGNED BY	ADRIAN B. SUN	DRAWN BY	ADRIAN B. SUN	CHECKED BY	ADRIAN B. SUN	SCALE	AS SHOWN	SHEET NO.	S-1.0	TOTAL SHEETS	1
CLIENT	THE UNIVERSITY OF THE PHILIPPINES - DILIGEN	PROJECT NO.	100-10-21-001	DATE	1/20/2020	DESIGNED BY	ADRIAN B. SUN	DRAWN BY	ADRIAN B. SUN	CHECKED BY	ADRIAN B. SUN	SCALE	AS SHOWN	SHEET NO.	S-1.0	TOTAL SHEETS	1

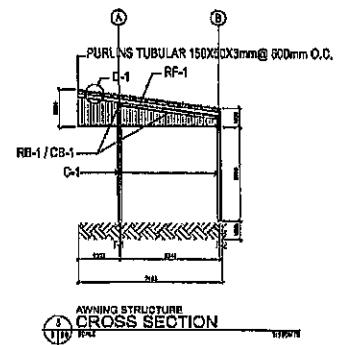
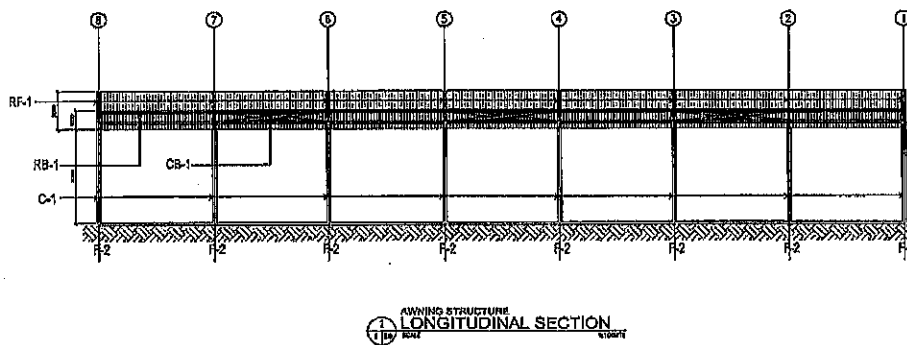
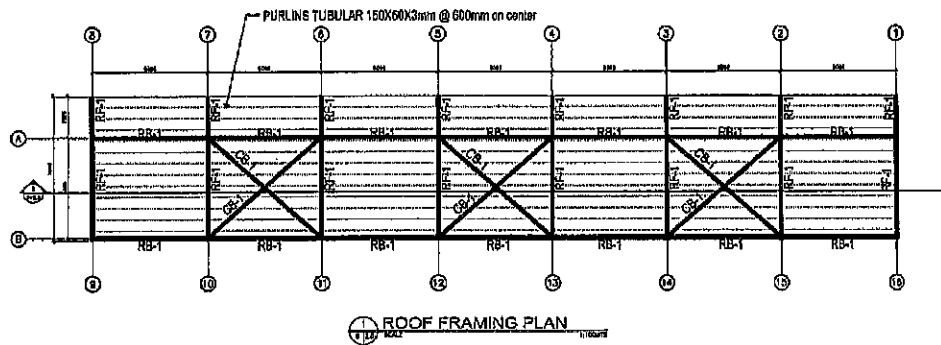

<p><b>JJGlobal</b> Technicals Maintenance • Logistics • Construction</p>	REVISIONS NO.   DATE   BY   DESCRIPTION	APPROVALS NAME   SIGNATURE   DATE   POSITION	PROJECT TITLE REPLACEMENT OF RAILING FOR METAL AWNING STRUCTURE	PROJECT NO.   I.D. NO.	SHEET NO.   TOTAL SHEETS
	CLIENT NAME PROJECT NO.	DESIGNER DATE	CHECKER DATE	PROJECT NO.   I.D. NO.	SHEET NO.   TOTAL SHEETS
	CLIENT NAME PROJECT NO.	DESIGNER DATE	CHECKER DATE	PROJECT NO.   I.D. NO.	SHEET NO.   TOTAL SHEETS
	CLIENT NAME PROJECT NO.	DESIGNER DATE	CHECKER DATE	PROJECT NO.   I.D. NO.	SHEET NO.   TOTAL SHEETS

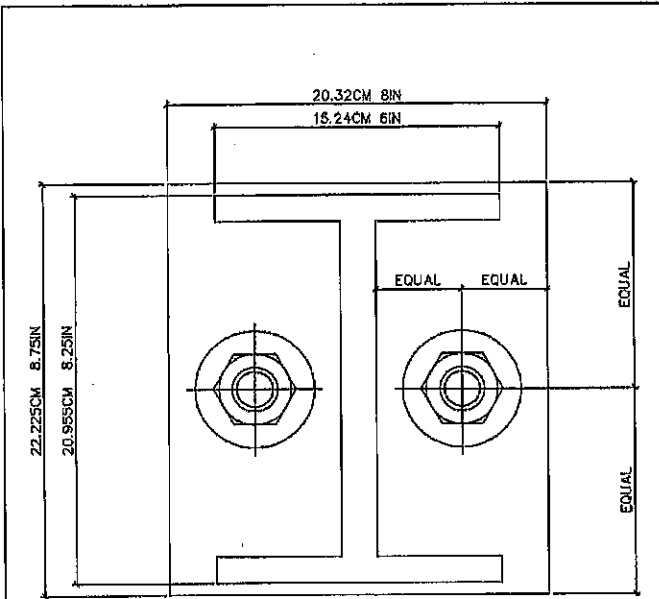

**EXISTING BASEPLATE**

**NOTE:**

IF ANCHOR BOLT IS UNUSABLE DUE TO CORROSION,  
IT WILL BE REPLACED WITH DRILLED TYPE ANCHOR BOLT.

**BASE PLATE DETAIL**  
REV 19 2022

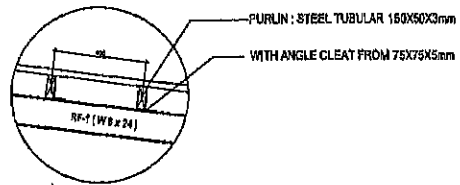

**D-1 DETAIL**

**COLUMN SCHEDULE**

GRADE ID	MARK	DIMENSION (mm)			
		D	Bf	tf	tw
BEAM HEAD	C-1 (W 8 x 35)	204.00	204.00	12.50	7.57

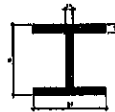

**BEAM SCHEDULE**

BEAM	MARK	DIMENSION (mm)				REMARKS
		D	Bf	tf	tw	
BEAM ROOF LEVEL						
	R1-1 (W 8 x 24)	201.00	155.00	10.20	5.22	RAFTER
	RB-3 (W 8 x 15)	152.00	152.00	6.63	5.84	ROOF BEAM
	CB-1 (STEEL TENSION ROD)	20.00	28.00	6.63	5.84	CROSS BEAM

**SCHEDULE OF BEAMS & COLUMNS**  
REV 19 2022

<p><b>JJGlobal</b> Facilities Maintenance • Logistics • Construction</p>	<p>PROJECT NO: 000-15-31-002</p> <p>REVISIONS OF DESIGN AND DRAWINGS</p>	<p>PROJECT NAME: SCHEDULE OF BEAMS &amp; COLUMNS</p>	<p>DATE: 19/10/2022</p>	<p>SCALE: 1/10</p>	<p>PROJECT NO: 000-15-31-002</p>	<p>PROJECT NAME: SCHEDULE OF BEAMS &amp; COLUMNS</p>	<p>DATE: 19/10/2022</p>	<p>SCALE: 1/10</p>	<p>PROJECT NO: 000-15-31-002</p>	<p>PROJECT NAME: SCHEDULE OF BEAMS &amp; COLUMNS</p>	<p>DATE: 19/10/2022</p>	<p>SCALE: 1/10</p>
	<p>DESIGNER: [Name]</p> <p>CHECKER: [Name]</p> <p>APPROVER: [Name]</p>	<p>DESIGNER: [Name]</p> <p>CHECKER: [Name]</p> <p>APPROVER: [Name]</p>	<p>DESIGNER: [Name]</p> <p>CHECKER: [Name]</p> <p>APPROVER: [Name]</p>	<p>DESIGNER: [Name]</p> <p>CHECKER: [Name]</p> <p>APPROVER: [Name]</p>	<p>DESIGNER: [Name]</p> <p>CHECKER: [Name]</p> <p>APPROVER: [Name]</p>	<p>DESIGNER: [Name]</p> <p>CHECKER: [Name]</p> <p>APPROVER: [Name]</p>	<p>DESIGNER: [Name]</p> <p>CHECKER: [Name]</p> <p>APPROVER: [Name]</p>	<p>DESIGNER: [Name]</p> <p>CHECKER: [Name]</p> <p>APPROVER: [Name]</p>	<p>DESIGNER: [Name]</p> <p>CHECKER: [Name]</p> <p>APPROVER: [Name]</p>	<p>DESIGNER: [Name]</p> <p>CHECKER: [Name]</p> <p>APPROVER: [Name]</p>	<p>DESIGNER: [Name]</p> <p>CHECKER: [Name]</p> <p>APPROVER: [Name]</p>	<p>DESIGNER: [Name]</p> <p>CHECKER: [Name]</p> <p>APPROVER: [Name]</p>

<mailto:virginia@jjglobal.services> >; Florenda Miranda  
<flor@jjglobal.services <mailto:flor@jjglobal.services> >; Admin Assistant  
<admin@jjglobal.services <mailto:admin@jjglobal.services> >  
Subject: Replacement of Bldg. 900 Metal Awning Structure

Hafa Adai Mr. Joleen,

I hope this email finds you well.

Kindly find attached Replacement of Bldg. 900 Metal Awning Structure of contract for your reference.

Please acknowledge receipt of this email.

Should you need further assistance, please do not hesitate to contact us.

Thank you

Best Regards,

Kit Casin

Executive Secretary

Services

PO Box 217881

GMF Barrigada GU 96921

Tel # 671-633-2603

email: kit.casin <mailto:kit.casin@jjglobal.services> @jjglobal.services

<<http://www.jjglobal.services/>> <http://www.jjglobal.services/>

## Joleen Evangelista

---

**From:** Aileen de Dios <aileen@jjglobal.services>  
**Sent:** Thursday, August 26, 2021 10:05 PM  
**To:** Joleen Evangelista  
**Cc:** Klt Casin; Virginia Tedpahogo; Julie Ulloa-Heath; Admin Assistant; Francisco 'Kiko' Palacios; Rodalyn Gerardo; Luis E. Bustamante  
**Subject:** Re: Replacement of Bldg. 900 Metal Awning Structure  
**Attachments:** GCC-FB-21-009- Replacement of Awning Structure .pdf

Hafa Adai Ms Joleen,

Pls see attached letter pursuant to the signing of the contract.

*All the best,*

**Aileen de Dios**  
*General Manager*  
<http://www.jjglobal.services/>  
E: [aileen@jjglobal.services](mailto:aileen@jjglobal.services)  
O: 671-632-1179  
F: 671-632-3550

On Wed, Aug 25, 2021 at 2:01 PM Joleen Evangelista <[joleen.evangelista@guamcc.edu](mailto:joleen.evangelista@guamcc.edu)> wrote:  
Dear Mr. Bustamante and the JJ Global Services Team:

I would like to follow up on the following for the items for the above project:

1. GCC needs the signed original contract by Mr. Luis Bustamante. On August 9, 2021, GCC was informed that he was off-island and that the signed contract would be submitted however, as of 8/25/2021 GCC has not received the signed contract. GCC Materials management Office has called to follow up by phone and in person however, it is Ms. Casin did not know status of the signed contract. The PO was acknowledged and received by JJ Global since 8/4/2021. Please note that Mr. Bustamante attended an on-site (informal post award) meeting on August 11, 2021 with additional JJ Global employees however, the signed contract was not submitted.
2. Please confirm if the drawings/plans for the project have been submitted to GCC Facilities Office (Dr. Julie Ulloa-Heath and Mr. Kiko Palacios). There was a request for additional time to submit the drawings to GCC for approval so that JJ Global can obtain the permit to start the project. Please confirm if the drawings are ready for submission to GCC



since the additional 15 days to submit the drawings has passed.

3. Is JJ Global able to proceed with this project and carry out all the required work to complete as stated in the bid? Please advise.

Please provide a response to this request ASAP or by Thursday, August 26, 2021 via email to: [materialsmanagement@guamcc.edu](mailto:materialsmanagement@guamcc.edu)  
<<mailto:materialsmanagement@guamcc.edu>> .

Thank you and Regards,

Joleen M. Evangelista

Procurement & Inventory Administrator

From: Joleen Evangelista [<mailto:joleen.evangelista@guamcc.edu>]  
Sent: Wednesday, August 4, 2021 4:17 PM  
To: 'Kit Casin' <[kit.casin@jjglobal.services](mailto:kit.casin@jjglobal.services)>  
Cc: 'Julie Ulloa-Heath' <[julie.ulloaheath@guamcc.edu](mailto:julie.ulloaheath@guamcc.edu)>; 'Aileen de Dios' <[aileen@jjglobal.services](mailto:aileen@jjglobal.services)>; 'Luis E. Bustamante' <[luis.bustamante34@gmail.com](mailto:luis.bustamante34@gmail.com)>; 'Virginia Tedpahogo' <[virginia@jjglobal.services](mailto:virginia@jjglobal.services)>; 'Florenda Miranda' <[flor@jjglobal.services](mailto:flor@jjglobal.services)>; 'Admin Assistant' <[admin@jjglobal.services](mailto:admin@jjglobal.services)>  
Subject: RE: Replacement of Bldg. 900 Metal Awning Structure

Kit,

Please see page 3 of 7 in the SOW titled: Bid Description Replacement of Building 900 Metal Awning Structure GCC Bid No: GCC-FB-21-009.

Item Number 18. B. states "Contractor's timeline to complete the project

within ninety (90) consecutive calendar days upon receipt of PO and inclusive of the building permit process and material lead-time". You may request for an extension if the permit process takes longer than what you anticipated when you submitted your bid. JJ Global may submit a request in writing asking for an extension because of the time it took to obtain a permit.

Thank you and Best Regards,

Joleen M. Evangelista

Procurement & Inventory Administrator

From: Kit Casin [<mailto:kit.casin@jjglobal.services>]  
Sent: Tuesday, August 3, 2021 4:25 PM  
To: Joleen Evangelista <[joleen.evangelista@guamcc.edu](mailto:joleen.evangelista@guamcc.edu)>  
<<mailto:joleen.evangelista@guamcc.edu>> >  
Cc: Julie Ulloa-Heath <[julie.ulloaheath@guamcc.edu](mailto:julie.ulloaheath@guamcc.edu)>  
<<mailto:julie.ulloaheath@guamcc.edu>> >; Aileen de Dios  
<[aileen@jjglobal.services](mailto:aileen@jjglobal.services) <<mailto:aileen@jjglobal.services>> >; Luis E.  
Bustamante <[luis.bustamante34@gmail.com](mailto:luis.bustamante34@gmail.com) <<mailto:luis.bustamante34@gmail.com>>  
>; Virginia Tedpahogo <[virginia@jjglobal.services](mailto:virginia@jjglobal.services)>  
<<mailto:virginia@jjglobal.services>> >; Florenda Miranda  
<[flor@jjglobal.services](mailto:flor@jjglobal.services) <<mailto:flor@jjglobal.services>> >; Admin Assistant  
<[admin@jjglobal.services](mailto:admin@jjglobal.services) <<mailto:admin@jjglobal.services>> >  
Subject: Replacement of Bldg. 900 Metal Awning Structure

Hafa Adai Mr. Joleen,

I hope this email finds you well.

Kindly find attached Replacement of Bldg. 900 Metal Awning Structure of contract for your reference.

Please acknowledge receipt of this email.

Should you need further assistance, please do not hesitate to contact us.

Thank you

Best Regards,

Kit Casin

Executive Secretary

Services

PO Box 217881

GMF Barrigada GU 96921

Tel # 671-633-2603

email: kit.casin <<mailto:kit.casin@jjglobal.services>> @jjglobal.services

<<http://www.jjglobal.services/>> <http://www.jjglobal.services/>

--

E-mail administered by Guam Community College



August 26, 2021

To: Guam Community College  
PO Box 23069, GMF, Guam 96921  
Attn: Joleen Evangelista (Procurement & Inventory Administrator)

Re: GCC-FB-21-009  
Replacement of Building 900 Metal Awning Structure

Dear Ms. Evangelista,

After having an opportunity to review the draft contract on August 9, 2021, we noted that the contract does not address the disclosures in our June 25th email regarding unanticipated delay and delays out of our control. These provisions were also confirmed in our July 6, 2021, letter. Specifically, in reference to the "Contract Time", the following language should be included.

"Completion Date may be extended forward in allotment to the number of days needed for any/all the following: delay of permit(s); delay due to weather conditions, i.e., natural disasters, storms, etc.; or delay due to the COVID-19 pandemic, including, but not limited to, materials not on Island."

Once the contract reflects this understanding, we can execute. Thank you.

Very respectfully,

Luis E. Bustamante  
President/CEO  
JJ Global Services

Physical Address: 215 Rojas Street, Suite 126 Harmon Industrial Park, Tamuning Guam, 96913  
Mailing Address: PO Box 217881, GMF Barrigada Guam 96921  
Tel: (671) 632-1179 Fax: (671) 632-3550  
Email: jjg@teleguam.net

GCC PR0313



**GUAM COMMUNITY COLLEGE**  
 Bill/Ship TO MATERIALS MANAGEMENT SECTION  
 P. O. Box 23069 GMF  
 Barrigada, Guam 96921-3069  
 1 Sesame St. Mangilao, Guam 96913  
 Website: www.guamcc.edu  
 Email: materialsmanagement@guamcc.edu  
 Phone: 671.735.5540/2 Fax: 671.734.5238

Purchase Order Number

P2101070

Issue Date: 07/27/21

Delivery Date: 07/27/21

Vendor:

B00145188  
 JJ Global Services  
 P.O. Box 217881 GMF  
 Barrigada GU 96921  
 Guam

Ship To:

Materials Management  
 PO Box 23069 GMF  
 Barrigada GU 96921

This Purchase Order Number must appear on all packages, shipping papers, correspondence, and invoices pertaining to the order. Please supply promptly the articles below or services. All invoices and statements must show the purchase order number to avoid delay in payment.

24 hour notice for large deliveries is recommended. Please call 671.735.5225 to make arrangements.

Billing instructions: Send certified invoice with three (3) copies to Bill/Ship to address only.

Shipping instructions: Make sure Bill/Ship to address appears on the crate or package. Invoice must accompany shipment.

ITEM	DESCRIPTION	QUANTITY	UOM	UNIT PRICE	EXTENDED AMOUNT
1	2015 Contractual Services Bid No. GCC-FB-21-009 Replacement of Building 900 Metal Awning Structure. Description of work and cost break down: a, b, c with Option 2 Galvanized, d, e, f, g, h, i) Total Cost \$163,263.84. Timeline to complete project within ninety (90) consecutive calendar days upon receipt of purchase order and inclusive of the building permit process and material lead-time. *****FOR INTERNAL USE ONLY*****  <i>Elmo Reus</i> <i>8-4-21</i> 		EA		163,263.84

REMARKS:

TOTAL AUTHORIZED

CONTINUED

FOR GUAM COMMUNITY COLLEGE USE ONLY

*Joleen M. Evangelista*

Joleen M. Evangelista  
 Procurement & Inventory Administrator

*R. Maganaris*

Rodalyn Gerardo, CIA, CGFM, CPA, CGAP, CGMA, CICA  
 Vice President, Finance & Administration  
 Certifying Officer

*Mary A. Y. Okada*

Mary A. Y. Okada, Ed.D.  
 President

JUL 28 2021

Date

MATERIALS MANAGEMENT

GCC PR0314



**GUAM COMMUNITY COLLEGE**  
 Bill/Ship TO MATERIALS MANAGEMENT SECTION  
 P. O. Box 23069 GMF  
 Barrigada, Guam 96921-3069  
 1 Sesame St. Mangilao, Guam 96913  
 Website: www.guamcc.edu  
 Email: materialmanagement@guamcc.edu  
 Phone: 671.735.5540/2 Fax: 671.734.5238

Purchase Order Number

P2101070

Issue Date: 07/27/21

Delivery Date: 07/27/21

This Purchase Order Number must appear on all packages, shipping papers, correspondence, and invoices pertaining to the order. Please supply promptly the articles below or services. All invoices and statements must show the purchase order number to avoid delay in payment.

24 hour notice for large deliveries is recommended. Please call 671.735.6825 to make arrangements.

Billing Instructions: Send certified invoice with three (3) copies to Bill/Ship to address only.

Shipping Instructions: Make sure Bill/Ship to address appears on the crate or package. Invoice must accompany shipment.

Vendor:

B00145188  
 JJ Global Services  
 P.O. Box 217881 GMF  
 Barrigada GU 96921  
 Guam

Ship To:

Materials Management  
 PO Box 23069 GMF  
 Barrigada GU 96921

ITEM	DESCRIPTION	QUANTITY	UOM	UNIT PRICE	EXTENDED AMOUNT
	Requestor: Francisco Palacios (P&D) FOAP: 30.1065.7230.66.P2106 (Contractual Services) Requisition: R2101180				

REMARKS:

DISCOUNT: .00  
 ADDL CHARGES: .00  
 TOTAL TAXES: .00

TOTAL AUTHORIZED 163,263.84

FOR GUAM COMMUNITY COLLEGE USE ONLY

*Joleen M. Evangelista*

Joleen M. Evangelista  
 Procurement & Inventory Administrator

*R. Magaranda*

Rodalyn Gerardo, CIA, CGFM, CPA, CGAP, CGMA, CICA  
 Vice President, Finance & Administration  
 Certifying Officer

*Mary A. Y. Okada*

Mary A. Y. Okada, Ed.D.  
 President

JUL 28 2021

Date

MATERIALS MANAGEMENT

**CONTRACT NO. P2101070**

**CONTRACT  
(Replacement of Building 900 Metal Awning Structure)**

**JJ Global Services  
(Contractor)**

**Guam Community College  
(GCC)**

**Bid No: GCC-FB-21-009**

**Amount: \$163,263.84**

**Place: Guam Community College**

## FORMAL CONTRACT

**THIS AGREEMENT AND FORMAL CONTRACT, made and entered into this 27th day of July 2021, by and between Guam Community College, hereinafter called "GCC", represented by the Contracting officer executing this contract, party of the first part, and JJ Global Services, a corporation of the Territory of Guam, hereinafter called the "Contractor" party of the second part.**

**WITNESSETH, That whereas the Guam Community College intends to Replace the Metal Awning Structure at Building 900 with galvanized iron (option 2) called the "Project", in accordance with the scope of work and other contract documents.**

**NOW THEREFORE, Guam Community College and Contractor for the considerations hereinafter set forth, agree as follows:**

**I. THE CONTRACTOR AGREES to construct and furnish all the necessary labor, materials, equipment, tools and services necessary to perform and complete in a safe and efficient manner all the work required for the performance of the Project, in strict compliance with the contract documents herein mentioned, which are hereby made a part of the contract.**

**(a) Contract Time:** The contractor agrees to commence work under this contract upon written notice to proceed which is established as July 27, 2021, and to complete the project ready for use and operation based on the below requirements:

**90 Calendar Days upon Notice to Proceed Date  
Completion Date: October 24, 2021**

**II. Guam Community College agrees to pay, subject to availability of funds, and the Contractor agrees to accept, in full payment for the performance of this contract, a total contract amount of \$163,263.84 using Galvanized Iron.**

**III. CONTRACT DOCUMENTS:** It is hereby mutually agreed that the following list of specifications and documents which are attached hereto, bound herewith or incorporated herein by reference shall constitute the contract documents, all of which are part hereof, and collectively evidence and constitute the contract between the parties hereto, and they are as fully a part of this Agreement as if they were set out verbatim and in full herein, and are designated as follows:

- (a) Instructions to Bidders**
- (b) Bid Form**
- (c) Bid Schedule**
- (d) Bid Bond**
- (e) Subcontractor: None**
- (f) Performance Bond**
- (g) General Provisions**



- (h) General Conditions
- (i) Special Provisions
- (j) SOW
- (k) Amendments

- IV. LIQUIDATED DAMAGES:** The Contractor further agrees to pay to GCC the sum of one-fourth of one percent (1%) of the contract amount per calendar day not as a penalty, but as reasonable liquidated damages for breach of this contract by the Contractor by his failing, neglecting or refusing to complete work within the time herein specified and said sums shall be paid for each consecutive calendar day thereafter that the Contractor shall be in default after the time stipulated in the contract for completing the work ready for use and/or operation. Liquidated damages will start after contract completion deadline.
- V. SPECIAL PERMITS AND LICENSES:** The Contractor shall, at his own expense, procure all permits, certificates, and licenses and shall give notices and necessary reports required by law for the Scope of Work. Failure to maintain required permits and licenses shall be grounds for immediate termination of contract.
- VI. CONTROL:** The GCC President or the Assistant Director, Planning & Development/Facilities will meet periodically with the Contractor for the purpose of reviewing progress and providing necessary guidance to the Contractor in solving problems.
- VII. JUSTIFICATION OF DELAY:** The Contractor guarantees that the project will be completed within the agreed upon completion date. If however, the Contractor cannot comply with the completion requirement, it is the Contractor's responsibility to advise GCC in writing explaining the cause and reasons for delay.
- VIII. GENERAL COMPLIANCE WITH LAWS:** In the performance of work provided herein, Contractor agrees that it shall be conducted in full compliance with any and all applicable laws, rules and regulation adopted or promulgated by any governmental agency or regulatory body, both territorial and federal. Contractor assumes full responsibility for the payment of all contributions payroll taxes or assessments, territorial or federal, and further agrees to meet all requirements that may be specified under regulations of administrative officials or bodies charged with enforcement of any territorial or federal laws.

- IX. EQUAL EMPLOYMENT OPPORTUNITY:** Section 3.01 OF THE Executive Order 10935 dated march 7, 1965 requires the Contractor not to discriminate against any employee or applicant for employment because of race, creed, color or national origin. The Contractor will take affirmative action to ensure that employees are treated equally during employment without regards to their race, creed, color or national origin.
- X. CONVENANT AGAINST CONTINGENT FEES.** The Contractor warrants that he has not employed any person to solicit or secure the contract upon any agreement for a commission, percentage, brokerage or contingent fee. Breach of this warranty shall give GCC the right to terminate the contract, or in its discretion, to deduct from the contract price or consideration the amount of such commission, percentage, brokerage or contingent fee. The warranty shall not apply to commissions payable by contractors upon contracts or sales secured or made through bonafide established commercial or selling agencies maintained by the Contractor for the purpose of securing business.
- XI. OTHER CONTRACTS.** GCC may award other contracts for additional work, and the Contractor shall fully cooperate with such other contractors and carefully fit his own work to that provided under other contracts as may be directed by the Contracting Officer. The Contractor shall not commit or permit any act which will interfere with the performance of work by any other contractor.
- XII. DISPUTES.** Except as otherwise specifically provided in this contract, all disputes concerning questions of fact arising under this contract shall be decided by the President of Guam Community College whose decision shall be final and conclusive upon the parties thereto. In the meantime the Contractor shall diligently proceed with the work as directed.
- XIII. CONTRACT BINDING.** It is agreed that this contract and all the Covenants hereof shall inure to the benefit of and be binding upon GCC and the Contractor respectively and his partners, successors, assignees and legal representatives. Neither GCC nor the Contractor shall have the right to assign, transfer or sublet his interest or obligations hereunder without written consent of the other party. It is hereby mutually agreed by and between the parties hereto that no mechanic, contractor, subcontractor, material man or other person can or will contract for or in any other manner have or acquire any lien upon the building or works covered by this contract, or the land upon which the same is situated.

- XIV. INDEMNITY.** Contractor agrees to save and hold harmless GCC, its officers, agents, representatives, successors and assigns and other governmental agencies from any and all suits or actions of every nature and kind, which may be brought for or on account of any injury, death, or damage arising or growing out of the acts or omissions of the Contractor, Contractor's officers, agents, servants or employees under this contract.
- XV. MODIFICATION OR AMENDMENTS:** No modification, amendment, alteration or change of the terms and conditions of this Agreement shall be valid or enforceable unless made in writing and executed by both parties hereto and approved by appropriate action by GCC.
- XVI. ATTORNEY FEES:** If either GCC or Contractor institute legal action to enforce the provisions of this Agreement, the prevailing party shall be entitled to recover reasonable attorney's fees and cost of suit.
- XVII. INSURANCE:** During the term of this agreement, Contractor must maintain insurance as required on the Notice of Intent to Award. Contractor is responsible for obtaining all applicable insurance. GCC assumes no liability for any accident or injury that may occur to the Contractor, his agents, dependents, or personal property while on GCC premises performing said scope of service.
- XVIII. ASSIGNMENT OF AGREEMENT:** Assignment will not be accepted without approval from GCC. Request for approval of assignment must be made with submission of proposal. No assignment will be accepted if request is not made in writing with the proposal.
- XIX. RESTRICTIONS AGAINST CONTRACTORS EMPLOYING CONVICTED SEX OFFENDERS:** The contractor warrants that no person in its employments who has been convicted of a sex offense under the provisions of Chapter 25 of Title 9 of the Guam Code Annotated, or who has been convicted of an offense with the same elements as heretofore defined in any other jurisdiction, or who is listed on the Sex Offender Registry shall provide services on behalf of the contractor while on government property, with the exception of public highways. If any employee of contractor is providing services on government property and is convicted subsequent to an award of a contract, then the contractor warrants that it will notify GCC of the conviction within twenty-four hours of the conviction, and will remove immediately such convicted person from providing services on government property. If the contractor is found to be in violation of any of the provisions of this paragraph, then GCC will give notice to the contractor to take corrective action. The contractor shall take corrective action within twenty-four hours of notice from GCC, and the contractor shall notify GCC when action has been taken. If the contractor fails to take corrective steps within twenty-four hours of notice from GCC, then GCC in its sole discretion may

suspend temporarily any contract for services until corrective action has been taken.

**XX. NOTICES:** All notices, requests, demands and other communications which are required or permitted to be given under this Agreement shall be made in writing and shall be deemed to have been duly given upon the delivery or receipt thereof, as the case may be, if delivered personally, or shall deemed to be received as of the date of mailing if sent by registered or certified mail, return receipt requested, postage prepaid as follows:

GCC: Guam Community College  
P.O. Box 23069  
GMF, Guam 96921

The Contractor: JJ Global Services  
P.O. Box 217881 GMF  
Barrigada, Guam 96921

**IN THIS WHEREOF parties hereto have executed this contract as of the day and year first written.**

\_\_\_\_\_  
Luis E. Bustamante  
CEO  
JJ Global Services

*Mary A. Okada on 06/20/21*  
\_\_\_\_\_  
Mary A. Okada, Ed.D. *Reg*  
President  
Guam Community College

**CERTIFIED FUNDS AVAILABE**

Contract No.: P2101070  
FOAP: 30.1065.7230.66.P2106 *pm 7/26/2021*  
Contract Amount: \$163,263.84



July 26, 2021

JJ Global Services  
P.O. Box 217881 GMF  
Barrigada, Guam 96921

Attention: Mr. Luis Bustamante  
CEO

Ms. Aileen de Dios  
General Manager

Subject: **Notification of Bid Award**

Bid No: GCC-FB-21-009  
Bid Description: Replacement of Building 900 Metal Awning Structure

Dear Mr. Bustamante and Ms. De Dios,

Your bid has been evaluated and is deemed the lowest, responsive, and responsible bid.

Guam Community College is pleased to inform you that the contract for the Replacement of Building 900 Metal Awning Structure will be awarded to JJ Global Services. The total bid amount for Option 2: Galvanized Iron is \$163,263.84.

The contract award date and Notice to Proceed date is July 27, 2021. Based on the 90 consecutive calendar days upon the issuance of the purchase order/contract, the deadline to complete this project is October 24, 2021. You will be contacted to pick up the purchase order/contract.

GCC will contact you to schedule the Post-Award meeting via Google Meet. Please be sure to inform all key JJ Global Services personnel who will be assigned to carry out this project. Please inform the Materials Management office of their email addresses so that we can send them an invite.

GCC thanks you for participating in this bid and looks forward to working with you.

If you have any questions or need additional information, please contact Joleen M. Evangelista at 735-5540 or email: [joleen.evangelista@guamcc.edu](mailto:joleen.evangelista@guamcc.edu).

Sincerely,

Mary A.Y. Okada, Ed.D.  
President

Ref

Emma Reyes  
8-4-21  
ER



August 26, 2021

To: Guam Community College  
PO Box 23069, GMF, Guam 96921  
Attn: Joleen Evangelista (Procurement & Inventory Administrator)

Re: GCC-FB-21-009  
Replacement of Building 900 Metal Awning Structure

Dear Ms. Evangelista,

After having an opportunity to review the draft contract on August 9, 2021, we noted that the contract does not address the disclosures in our June 25th email regarding unanticipated delay and delays out of our control. These provisions were also confirmed in our July 6, 2021, letter. Specifically, in reference to the "Contract Time", the following language should be included.

"Completion Date may be extended forward in allotment to the number of days needed for any/all the following: delay of permit(s); delay due to weather conditions, i.e., natural disasters, storms, etc.; or delay due to the COVID-19 pandemic, including, but not limited to, materials not on Island."

Once the contract reflects this understanding, we can execute. Thank you.

Very respectfully,

Luis E. Bustamante  
President/CEO  
JJ Global Services

Physical Address: 215 Rojas Street, Suite 126 Harmon Industrial Park, Tamuning Guam, 96913  
Mailing Address: PO Box 217881, GMF Barrigada Guam 96921  
Tel: (671) 632-1179 Fax: (671) 632-3550  
Email: [jjg@teleguam.net](mailto:jjg@teleguam.net)

GCC PR0323

free  
GCC-FB-21-009

**Joleen Evangelista**

---

**From:** Aileen de Dios <aileen@jjglobal.services>  
**Sent:** Thursday, August 26, 2021 10:05 PM  
**To:** Joleen Evangelista  
**Cc:** Kit Casin; Virginia Tedpahogo; Julie Ulloa-Heath; Admin Assistant; Francisco 'Kiko' Palacios; Rodalyn Gerardo; Luis E. Bustamante  
**Subject:** Re: Replacement of Bldg. 900 Metal Awning Structure  
**Attachments:** GCC-FB-21-009- Replacement of Awning Structure .pdf

Hafa Adai Ms Joleen,

Pls see attached letter pursuant to the signing of the contract.

*All the best,*

**Aileen de Dios**  
*General Manager*  
<http://www.jjglobal.services/>  
E: [aileen@jjglobal.services](mailto:aileen@jjglobal.services)  
O: 671-632-1179  
F: 671-632-3550

On Wed, Aug 25, 2021 at 2:01 PM Joleen Evangelista <[joleen.evangelista@guamcc.edu](mailto:joleen.evangelista@guamcc.edu)> wrote:  
Dear Mr. Bustamante and the JJ Global Services Team:

I would like to follow up on the following for the items for the above project:

1. GCC needs the signed original contract by Mr. Luis Bustamante. On August 9, 2021, GCC was informed that he was off-island and that the signed contract would be submitted however, as of 8/25/2021 GCC has not received the signed contract. GCC Materials management Office has called to follow up by phone and in person however, it is Ms. Casin did not know status of the signed contract. The PO was acknowledged and received by JJ Global since 8/4/2021. Please note that Mr. Bustamante attended an on-site (informal post award) meeting on August 11, 2021 with additional JJ Global employees however, the signed contract was not submitted.
2. Please confirm if the drawings/plans for the project have been submitted to GCC Facilities Office (Dr. Julie Ulloa-Heath and Mr. Kiko Palacios). There was a request for additional time to submit the drawings to GCC for approval so that JJ Global can obtain the permit to start the project. Please confirm if the drawings are ready for submission to GCC

since the additional 15 days to submit the drawings has passed.

3. Is JJ Global able to proceed with this project and carry out all the required work to complete as stated in the bid? Please advise.

Please provide a response to this request ASAP or by Thursday, August 26, 2021 via email to: [materialsmanagement@guamcc.edu](mailto:materialsmanagement@guamcc.edu)  
<<mailto:materialsmanagement@guamcc.edu>> .

Thank you and Regards,

Joleen M. Evangelista

Procurement & Inventory Administrator

From: Joleen Evangelista [<mailto:joleen.evangelista@guamcc.edu>]  
Sent: Wednesday, August 4, 2021 4:17 PM  
To: 'Kit Casin' <[kit.casin@jjglobal.services](mailto:kit.casin@jjglobal.services)>  
Cc: 'Julie Ulloa-Heath' <[julie.ulloaheath@guamcc.edu](mailto:julie.ulloaheath@guamcc.edu)>; 'Aileen de Dios' <[aileen@jjglobal.services](mailto:aileen@jjglobal.services)>; 'Luis E. Bustamante' <[luis.bustamante34@gmail.com](mailto:luis.bustamante34@gmail.com)>; 'Virginia Tedpahogo' <[virginia@jjglobal.services](mailto:virginia@jjglobal.services)>; 'Florenda Miranda' <[flor@jjglobal.services](mailto:flor@jjglobal.services)>; 'Admin Assistant' <[admin@jjglobal.services](mailto:admin@jjglobal.services)>  
Subject: RE: Replacement of Bldg. 900 Metal Awning Structure

Kit,

Please see page 3 of 7 in the SOW titled: Bid Description Replacement of Building 900 Metal Awning Structure GCC Bid No: GCC-FB-21-009.

Item Number 18. B. states "Contractor's timeline to complete the project



within ninety (90) consecutive calendar days upon receipt of PO and inclusive of the building permit process and material lead-time". You may request for an extension if the permit process takes longer than what you anticipated when you submitted your bid. JJ Global may submit a request in writing asking for an extension because of the time it took to obtain a permit.

Thank you and Best Regards,

Joleen M. Evangelista

Procurement & Inventory Administrator

From: Kit Casin [mailto:[kit.casin@jjglobal.services](mailto:kit.casin@jjglobal.services)]  
Sent: Tuesday, August 3, 2021 4:25 PM  
To: Joleen Evangelista <[joleen.evangelista@guamcc.edu](mailto:joleen.evangelista@guamcc.edu)>  
<<mailto:joleen.evangelista@guamcc.edu>> >  
Cc: Julie Ulloa-Heath <[julie.ulloaheath@guamcc.edu](mailto:julie.ulloaheath@guamcc.edu)>  
<<mailto:julie.ulloaheath@guamcc.edu>> >; Aileen de Dios  
<[aileen@jjglobal.services](mailto:aileen@jjglobal.services) <<mailto:aileen@jjglobal.services>> >; Luis E.  
Bustamante <[luis.bustamante34@gmail.com](mailto:luis.bustamante34@gmail.com) <<mailto:luis.bustamante34@gmail.com>>  
>; Virginia Tedpahogo <[virginia@jjglobal.services](mailto:virginia@jjglobal.services)>  
<<mailto:virginia@jjglobal.services>> >; Florenda Miranda  
<[flor@jjglobal.services](mailto:flor@jjglobal.services) <<mailto:flor@jjglobal.services>> >; Admin Assistant  
<[admin@jjglobal.services](mailto:admin@jjglobal.services) <<mailto:admin@jjglobal.services>> >  
Subject: Replacement of Bldg. 900 Metal Awning Structure

Hafa Adai Mr. Joleen,

I hope this email finds you well.

Kindly find attached Replacement of Bldg. 900 Metal Awning Structure of contract for your reference.

Please acknowledge receipt of this email.

Item Number 18. B. states "Contractor's timeline to complete the project within ninety (90) consecutive calendar days upon receipt of PO and inclusive of the building permit process and material lead-time". You may request for an extension if the permit process takes longer than what you anticipated when you submitted your bid. JI Global may submit a request in writing asking for an extension because of the time it took to obtain a permit.

Thank you and Best Regards,

Joleen M. Evangelista  
Procurement & Inventory Administrator

**From:** Kit Casin [<mailto:kit.casin@jiglobal.services>]  
**Sent:** Tuesday, August 3, 2021 4:25 PM  
**To:** Joleen Evangelista <[joleen.evangelista@guamcc.edu](mailto:joleen.evangelista@guamcc.edu)>  
**Cc:** Julie Ulloa-Heath <[julie.ulloaheath@guamcc.edu](mailto:julie.ulloaheath@guamcc.edu)>; Aileen de Dios <[aileen@jiglobal.services](mailto:aileen@jiglobal.services)>; Luis E. Bustamante <[luis.bustamante34@gmail.com](mailto:luis.bustamante34@gmail.com)>; Virginia Tedpahogo <[virginia@jiglobal.services](mailto:virginia@jiglobal.services)>; Florenda Miranda <[flor@jiglobal.services](mailto:flor@jiglobal.services)>; Admin Assistant <[admin@jiglobal.services](mailto:admin@jiglobal.services)>  
**Subject:** Replacement of Bldg. 900 Metal Awning Structure

Hafa Adai Mr. Joleen,

I hope this email finds you well.

Kindly find attached Replacement of Bldg. 900 Metal Awning Structure of contract for your reference.

Please acknowledge receipt of this email.

Should you need further assistance, please do not hesitate to contact us.

Thank you

Best Regards,  
Kit Casin  
*Executive Secretary*

 Services  
PO Box 217881  
GMF Barrigada GU 96921  
Tel # 671-633-2603  
email: [kit.casin@jiglobal.services](mailto:kit.casin@jiglobal.services)  
<http://www.jiglobal.services/>

## Joleen Evangelista

---

**From:** Joleen Evangelista <joleen.evangelista@guamcc.edu>  
**Sent:** Thursday, July 29, 2021 5:24 PM  
**To:** 'Kit Casin'  
**Cc:** 'Luis E. Bustamante'; 'Aileen de Dios'; 'Admin Assistant'; 'materialsmanagement@guamcc.edu'; 'Julie Ulloa-Heath'; 'Francisco 'Kiko' Palacios'; 'Josephine.arceo@guamcc.edu'; 'Rodalyn Gerardo'; 'Virginia Tedpahogo'; 'Florenda Miranda'  
**Subject:** RE: Bid Award and Contract for GCC-FB-21-009 Replacement of Building 900 Metal Awning Structure

Ms. Casin,

Thank you for the acknowledgement receipt of the Bid Award and Contract via email. Please note that a copy of the purchase order for this project was also sent via email for acknowledgement as well on 7/28/2021. Please note that the original documents are ready for a representative from JJ Global to pick it up. Please have someone pick up the original documents tomorrow, Friday, July 30, 2021. Is JJ Global able to comply and perform the work required in this construction project?

The two (2) days will be adjusted since JJ Global just acknowledged today however, please refer back to the bid SOW. It states "Contractor's timeline to complete the project within ninety (90) consecutive calendar days upon receipt of PO and inclusive of the building permit process and material lead-time". You may request for an extension if the permit process takes longer than what you anticipated when you submitted your bid. JJ Global may submit a request in writing asking for an extension because of the time it took to obtain a permit.

Please advise if you have any additional questions.

Thank you and Regards,

Joleen M. Evangelista  
Procurement & Inventory Administrator

**From:** Kit Casin [mailto:kit.casin@jjglobal.services]  
**Sent:** Thursday, July 29, 2021 10:12 AM  
**To:** Joleen Evangelista <joleen.evangelista@guamcc.edu>  
**Cc:** Luis E. Bustamante <luis.bustamante34@gmail.com>; Aileen de Dios <aileen@jjglobal.services>; Admin Assistant <admin@jjglobal.services>; materialsmanagement@guamcc.edu; Julie Ulloa-Heath <julie.ulloaheath@guamcc.edu>; Francisco 'Kiko' Palacios <francisco.palacios1@guamcc.edu>; Josephine.arceo@guamcc.edu; Rodalyn Gerardo <rodalyn.gerardo@guamcc.edu>; Virginia Tedpahogo <virginia@jjglobal.services>; Florenda Miranda <flor@jjglobal.services>  
**Subject:** Re: Bid Award and Contract for GCC-FB-21-009 Replacement of Building 900 Metal Awning Structure

Hafa Adai Ms. Joleen,

I hope this email finds you well. Apologies for the late reply.

Kindly find the attached letter of our reply for the said email.  
Please refer to the letter of our response for the notice to proceed.

Please advise.

Should you need further assistance, please do not hesitate to contact us.

Thank you

Best Regards,  
Kit Casin  
*Executive Secretary*

 Services

PO Box 217881

GMF Barrigada GU 96921

Tel # 671-633-2603

email: [kit.casin@jjglobal.services](mailto:kit.casin@jjglobal.services)

<http://www.jjglobal.services/>

On Tue, Jul 27, 2021 at 4:46 PM Joleen Evangelista <[joleen.evangelista@guamcc.edu](mailto:joleen.evangelista@guamcc.edu)> wrote:

Mr. Bustamante and Ms. De Dios,

GCC is pleased to issue the attached Bid Award letter and contract for the Replacement of Building 900 Metal Awning Structure. Please review and sign the contract and return the signed contract to GCC. The original letter, contract, and PO can be picked up in the Materials Management Office any time between 8 am and 5 pm tomorrow, 7/28/21.

GCC would also like to schedule the Post Award google meeting this week. Are you available to meet tomorrow afternoon at 3 pm or on Thursday morning 7/29/2021 at 9 am? Please advise of all email addresses of key personnel assigned to this project.

Please advise if you have any questions.

Thank you and Best Regards,

Joleen M. Evangelista  
Procurement & Inventory Administrator

--

E-mail administered by Guam Community College

## Joleen Evangelista

---

**From:** virginia@jjglobal.services  
**Sent:** Monday, August 9, 2021 11:51 AM  
**To:** joleen.evangelista@guamcc.edu  
**Cc:** 'Luis Bustamante'; 'Aileen de Dios'; 'Kit Casin'; 'Admin'; 'Julie Ulloa-Heath'; 'Francisco 'Kiko' Palacios'  
**Subject:** RE: Bid Award & Contract for GCC-FB-21-009

Hello Ms Joleen,

I followed up on the Contract and was informed the Contract will be expedited via postal service to Mr. Bustamante as he is currently off-island. If I can be of any further assistance, please feel free to contact me. Thank you and have a Safe Day.

**Please acknowledge receipt of this email transmission!**

Sincerely,  
VIRGINIA M. TEDPAHOGO  
Collection Administrator  
virginia@jjglobal.services



Website: <http://www.jjglobal.services>

---

**From:** Joleen Evangelista <joleen.evangelista@guamcc.edu>  
**Sent:** Friday, August 6, 2021 6:28 PM  
**To:** virginia@jjglobal.services  
**Cc:** 'Luis Bustamante' <luis.bustamante@jjglobal.services>; 'Aileen de Dios' <aileen@jjglobal.services>; 'Kit Casin' <kit.casin@jjglobal.services>; 'Admin' <admin@jjglobal.services>; 'Julie Ulloa-Heath' <julie.ulloaheath@guamcc.edu>; Francisco 'Kiko' Palacios <francisco.palacios1@guamcc.edu>  
**Subject:** RE: Bid Award & Contract for GCC-FB-21-009

Ms. Tepahago,

This is to confirm receipt of your letter. I have included Ms. Julie Ulloa-Heath and Mr. Kiko Palacios on this email regarding the request for time extension for this project.

I would like to follow up on the signed contract from JJ Global. The original documents were picked up from our office on 8/4/2021. Please submit.

Thank you.

Joleen M. Evangelista  
Procurement & Inventory Administrator

---

**From:** [virginia@jjglobal.services](mailto:virginia@jjglobal.services) [mailto:[virginia@jjglobal.services](mailto:virginia@jjglobal.services)]  
**Sent:** Friday, August 6, 2021 5:48 PM  
**To:** [joleen.evangelista@guamcc.edu](mailto:joleen.evangelista@guamcc.edu)  
**Cc:** Luis Bustamante <[luis.bustamante@jjglobal.services](mailto:luis.bustamante@jjglobal.services)>; Aileen de Dios <[aileen@jjglobal.services](mailto:aileen@jjglobal.services)>; Kit Casin <[kit.casin@jjglobal.services](mailto:kit.casin@jjglobal.services)>; Admin <[admin@jjglobal.services](mailto:admin@jjglobal.services)>  
**Subject:** Bid Award & Contract for GCC-FB-21-009

Buenas Ms. Joleen,

Find herein attached, a transmittal letter from Ms. Aileen de Dios, GM for JJ Global Services. Thank you and have a safe weekend.

<< File: GCC Awning Letter 8.6.21.pdf >>

**Please acknowledge receipt of this email transmission**

Sincerely,  
**VIRGINIA M. TEDPAHOGO**  
Collection Administrator  
[virginia@jjglobal.services](mailto:virginia@jjglobal.services)

<< OLE Object: Picture (Device Independent Bitmap) >>  
PO Box 217881 Barrigada, GU 96921  
Telephone Number: 671.632.1179  
Facsimile Number: 671.632.3550  
Website: <http://www.jjglobal.services>

**CONFIDENTIALITY NOTICE:**

*This electronic message transmission and any attachments to it has been sent for the sole purpose of the intended recipient(s). If you are not an intended recipient, you are hereby notified that any unauthorized dissemination, distribution, or copying of this message, or any attachment, is strictly prohibited. Any use of this information and its attachments, without consent of the sender is punishable by law. Furthermore, the sender does not accept any responsibility for any loss, disruption or damage to your data or computer system that may occur while using data contained in, or transmitted with, this e-mail and its attachments. If you have received this communication in error, please notify the sender and immediately delete or otherwise destroy the original message and all attachments.*

## Joleen Evangelista

---

**From:** virginia@jjglobal.services  
**Sent:** Monday, August 9, 2021 11:55 AM  
**To:** joleen.evangelista@guamcc.edu  
**Cc:** 'Luis Bustamante'; 'Aileen de Dios'; 'Kit Casin'; 'Admin'; 'Julie Ulloa-Heath'; 'Francisco 'Kiko' Palacios'  
**Subject:** RE: Bid Award & Contract for GCC-FB-21-009  
  
**Importance:** High

Hi again Ms. Joleen,

In addition to the Contract. May I please gain status on the request for Extension. Has JJ Global's request been approved for the Extension, your kind and immediate response is greatly appreciated.

Virginia

---

**From:** Joleen Evangelista <joleen.evangelista@guamcc.edu>  
**Sent:** Friday, August 6, 2021 6:28 PM  
**To:** virginia@jjglobal.services  
**Cc:** 'Luis Bustamante' <luis.bustamante@jjglobal.services>; 'Aileen de Dios' <aileen@jjglobal.services>; 'Kit Casin' <kit.casin@jjglobal.services>; 'Admin' <admin@jjglobal.services>; 'Julie Ulloa-Heath' <julie.ulloaheath@guamcc.edu>; Francisco 'Kiko' Palacios <francisco.palacios1@guamcc.edu>  
**Subject:** RE: Bid Award & Contract for GCC-FB-21-009

Ms. Tepahago,

This is to confirm receipt of your letter. I have included Ms. Julie Ulloa-Heath and Mr. Kiko Palacios on this email regarding the request for time extension for this project.

I would like to follow up on the signed contract from JJ Global. The original documents were picked up from our office on 8/4/2021. Please submit.

Thank you.

Joleen M. Evangelista  
Procurement & Inventory Administrator

---

**From:** virginia@jjglobal.services [mailto:virginia@jjglobal.services]  
**Sent:** Friday, August 6, 2021 5:48 PM  
**To:** joleen.evangelista@guamcc.edu  
**Cc:** Luis Bustamante <luis.bustamante@jjglobal.services>; Aileen de Dios <aileen@jjglobal.services>; Kit Casin <kit.casin@jjglobal.services>; Admin <admin@jjglobal.services>  
**Subject:** Bid Award & Contract for GCC-FB-21-009

Buenas Ms. Joleen,

Find herein attached, a transmittal letter from Ms. Aileen de Dios, GM for JJ Global Services. Thank you and have a safe weekend.

<< File: GCC Awning Letter 8.6.21.pdf >>

**Please acknowledge receipt of this email transmission**

Sincerely,

**VIRGINIA M. TEDPAHOGO**

Collection Administrator

[virginia@jjglobal.services](mailto:virginia@jjglobal.services)

<< OLE Object: Picture (Device Independent Bitmap) >>

PO Box 217881 Barrigada, GU 96921

Telephone Number: 671.632.1179

Facsimile Number: 671.632.3550

Website: <http://www.jjglobal.services>

**CONFIDENTIALITY NOTICE:**

*This electronic message transmission and any attachments to it has been sent for the sole purpose of the intended recipient(s). If you are not an intended recipient, you are hereby notified that any unauthorized dissemination, distribution, or copying of this message, or any attachment, is strictly prohibited. Any use of this information and its attachments, without consent of the sender is punishable by law. Furthermore, the sender does not accept any responsibility for any loss, disruption or damage to your data or computer system that may occur while using data contained in, or transmitted with, this e-mail and its attachments. If you have received this communication in error, please notify the sender and immediately delete or otherwise destroy the original message and all attachments.*



**Joleen Evangelista**

---

**From:** virginia@jjglobal.services  
**Sent:** Monday, August 9, 2021 10:55 AM  
**To:** joleen.evangelista@guamcc.edu  
**Subject:** RE: Bid Award & Contract for GCC-FB-21-009

Hi Ms. Joleen,

Aileen de Dios / GM will be servicing you on the Contract. Thank you and be safe.

**Please acknowledge receipt of this email transmission:**

Sincerely,  
VIRGINIA M. TEDPAHOGO  
Collection Administrator  
virginia@jjglobal.services



Website: <http://www.jjglobal.services>

---

**From:** Joleen Evangelista <joleen.evangelista@guamcc.edu>  
**Sent:** Friday, August 6, 2021 6:28 PM  
**To:** virginia@jjglobal.services  
**Cc:** 'Luis Bustamante' <luis.bustamante@jjglobal.services>; 'Aileen de Dios' <aileen@jjglobal.services>; 'Kit Casin' <kit.casin@jjglobal.services>; 'Admin' <admin@jjglobal.services>; 'Julie Ulloa-Heath' <julle.ulloaheath@guamcc.edu>; Francisco 'Kiko' Palacios <francisco.palacios1@guamcc.edu>  
**Subject:** RE: Bid Award & Contract for GCC-FB-21-009

Ms. Tepahago,

This is to confirm receipt of your letter. I have included Ms. Julie Ulloa-Heath and Mr. Kiko Palacios on this email regarding the request for time extension for this project.

I would like to follow up on the signed contract from JJ Global. The original documents were picked up from our office on 8/4/2021. Please submit.

Thank you.

Joleen M. Evangelista  
Procurement & Inventory Administrator

**From:** [virginia@jjglobal.services](mailto:virginia@jjglobal.services) [mailto:[virginia@jjglobal.services](mailto:virginia@jjglobal.services)]  
**Sent:** Friday, August 6, 2021 5:48 PM  
**To:** [joleen.evangelista@guamcc.edu](mailto:joleen.evangelista@guamcc.edu)  
**Cc:** Luis Bustamante <[luis.bustamante@jjglobal.services](mailto:luis.bustamante@jjglobal.services)>; Aileen de Dios <[aileen@jjglobal.services](mailto:aileen@jjglobal.services)>; Kit Casin <[kit.casin@jjglobal.services](mailto:kit.casin@jjglobal.services)>; Admin <[admin@jjglobal.services](mailto:admin@jjglobal.services)>  
**Subject:** Bid Award & Contract for GCC-FB-21-009

Buenas Ms. Joleen,

Find herein attached, a transmittal letter from Ms. Aileen de Dios, GM for JJ Global Services. Thank you and have a safe weekend.

<< File: GCC Awning Letter 8.6.21.pdf >>

~~Please acknowledge receipt of this email transmission~~

Sincerely,

**VIRGINIA M. TEDPAHOGO**

Collection Administrator

[virginia@jjglobal.services](mailto:virginia@jjglobal.services)

<< OLE Object: Picture (Device Independent Bitmap) >>

PO Box 217881 Barrigada, GU 96921

Telephone Number: 671.632.1179

Facsimile Number: 671.632.3550

Website: <http://www.jjglobal.services>

**CONFIDENTIALITY NOTICE:**

*This electronic message transmission and any attachments to it has been sent for the sole purpose of the intended recipient(s). If you are not an intended recipient, you are hereby notified that any unauthorized dissemination, distribution, or copying of this message, or any attachment, is prohibited. Any use of this information and its attachments, without consent of the sender is punishable by law. Furthermore, the sender does not accept any responsibility for any loss, disruption or damage to your data or computer system that may occur while using data contained in, or transmitted with, this e-mail and its attachments. If you have received this communication in error, please notify the sender and immediately delete or otherwise destroy the original message and all attachments.*

## Joleen Evangelista

---

**From:** Francisco Palacios <francisco.palacios1@guamcc.edu>  
**Sent:** Monday, August 9, 2021 10:10 AM  
**To:** Joleen Evangelista  
**Cc:** Julie Ulloa-Heath  
**Subject:** Re: FW: Bid Award & Contract for GCC-FB-21-009

These Extensions should have been brought up in the beginning (during the bid phase) as it dealt with our requirement for completion days. JJ Global did not ask about this at the time. I am hesitant to approve this at the moment, however, it is Dr. Julie's call.

On Fri, Aug 6, 2021 at 6:28 PM Joleen Evangelista <[joleen.evangelista@guamcc.edu](mailto:joleen.evangelista@guamcc.edu)> wrote:  
Kiko and Julie,

Please see the attached letter from JJ Global requesting an extension for the plans for GCC to approve. Please advise.

Thanks,

Joleen

---

**From:** [virginia@jjglobal.services](mailto:virginia@jjglobal.services) [mailto:[virginia@jjglobal.services](mailto:virginia@jjglobal.services)]  
**Sent:** Friday, August 6, 2021 5:48 PM  
**To:** [joleen.evangelista@guamcc.edu](mailto:joleen.evangelista@guamcc.edu)  
**Cc:** Luis Bustamante <[luis.bustamante@jjglobal.services](mailto:luis.bustamante@jjglobal.services)>; Aileen de Dios <[aileen@jjglobal.services](mailto:aileen@jjglobal.services)>; Kit Casin <[kit.casin@jjglobal.services](mailto:kit.casin@jjglobal.services)>; Admin <[admin@jjglobal.services](mailto:admin@jjglobal.services)>  
**Subject:** Bid Award & Contract for GCC-FB-21-009

Buenas Ms. Joleen,

Find herein attached, a transmittal letter from Ms. Aileen de Dios, GM for JJ Global Services. Thank you and have a safe weekend.

Please acknowledge receipt of this email transmission.

Sincerely,  
VIRGINIA M. TEDPAHOGO  
Collection Administrator  
[virginia@jjglobal.services](mailto:virginia@jjglobal.services) <mailto:[virginia@jjglobal.services](mailto:virginia@jjglobal.services)>

PO Box 217881 Barrigada, GU 96921  
Telephone Number: 671.632.1179  
Facsimile Number: 671.632.3550

Website: <http://www.jjglobal.services> <<http://www.jjglobal.services/>>

**CONFIDENTIALITY NOTICE:**

This electronic message transmission and any attachments to it has been sent for the sole purpose of the intended recipient(s). If you are not an intended recipient, you are hereby notified that any unauthorized dissemination, distribution, or copying of this message, or any attachment, is strictly prohibited. Any use of this information and its attachments, without consent of the sender is punishable by law. Furthermore, the sender does not accept any responsibility for any loss, disruption or damage to your data or computer system that may occur while using data contained in, or transmitted with, this e-mail and its attachments. If you have received this communication in error, please notify the sender and immediately delete or otherwise destroy the original message and all attachments.

--

E-mail administered by Guam Community College

--

Francisco "Kiko" Palacios  
Guam Community College  
Planning and Development Dept.  
Sustainability and Project Coordinator  
(w)671-735-5501  
(c) 671-777-8087

"Nature is inexhaustibly sustainable if we care for it. It is our universal responsibility to pass a healthy earth onto future generations."

— Sylvia Dolson



*E-mail administered by Guam Community College*



**JJGlobal**

Facilities Maintenance • Logistics • Construction

**VIA EMAIL:**

joleen.evangelista@guamcc.edu

GUAM COMMUNITY COLLEGE

Attn.: Joleen Evangelista / Procurement & Inventory Administrator

Po Box 23069

GMF Barrigada, GU 96921

Friday, August 6, 2021

**Re.: Bid Award and Contract for GCC-FB-21-009 Replacement of Building 900 Metal Awning Structure**

Dear Ms. Joleen,

To confirm this Bid Award, JJ Global would like to request an extension for the completion date for an additional fifteen (15) working days. The design will take two (2) weeks to be completed, thus then we will furnish the design to your good office for approval. The design will be needed to obtain a Building Permit. Seeking your kind approval, thank you and have a great weekend.

Sincerely,

  
Aileen de Dios  
General Manager

vmt

Shop Address: 351 Alageta Street, Dededo Guam 96929  
Office Address: 185 Ilipog Drive, Bldg A Suite 203 Hannon Business Center, Tamuning Guam, 96913  
Mailing Address: PO Box 217881, GMF Barrigada Guam 96921  
Tel: (671) 632-1179 Fax: (671) 632-3550  
Email: jjg@tefeguam.net

GCC PR0340

## Joleen Evangelista

---

**From:** Joleen Evangelista <joleen.evangelista@guamcc.edu>  
**Sent:** Wednesday, August 4, 2021 4:17 PM  
**To:** 'Kit Casin'  
**Cc:** 'Julie Ulloa-Heath'; 'Aileen de Dios'; 'Luis E. Bustamante'; 'Virginia Tedpahogo'; 'Florenda Miranda'; 'Admin Assistant'  
**Subject:** RE: Replacement of Bldg. 900 Metal Awning Structure

Kit,

Please see page 3 of 7 in the SOW titled: Bid Description Replacement of Building 900 Metal Awning Structure GCC Bid No: GCC-FB-21-009.

Item Number 18. B. states "Contractor's timeline to complete the project within ninety (90) consecutive calendar days upon receipt of PO and inclusive of the building permit process and material lead-time". You may request for an extension if the permit process takes longer than what you anticipated when you submitted your bid. JJ Global may submit a request in writing asking for an extension because of the time it took to obtain a permit.

Thank you and Best Regards,

Joleen M. Evangelista  
Procurement & Inventory Administrator

**From:** Kit Casin [mailto:kit.casin@jjglobal.services]  
**Sent:** Tuesday, August 3, 2021 4:25 PM  
**To:** Joleen Evangelista <joleen.evangelista@guamcc.edu>  
**Cc:** Julie Ulloa-Heath <julie.ulloaheath@guamcc.edu>; Aileen de Dios <aileen@jjglobal.services>; Luis E. Bustamante <luis.bustamante34@gmail.com>; Virginia Tedpahogo <virginia@jjglobal.services>; Florenda Miranda <flor@jjglobal.services>; Admin Assistant <admin@jjglobal.services>  
**Subject:** Replacement of Bldg. 900 Metal Awning Structure

Hafa Adai Mr. Joleen,

I hope this email finds you well.

Kindly find attached Replacement of Bldg. 900 Metal Awning Structure of contract for your reference.

Please acknowledge receipt of this email.

Should you need further assistance, please do not hesitate to contact us.

Thank you

Best Regards,  
Kit Casin  
*Executive Secretary*

 Services



**VIA FACSIMILE:**

joleen.evangelista@guamcc.edu

GUAM COMMUNITY COLLEGE  
Attn.: Joleen Evangelista / Procurement & Inventory Administrator  
Po Box 23069  
GMF Barrigada, GU 96921

Tuesday, August 3, 2021

**Re.: Bid Award and Contract for GCC-FB-21-009 Replacement of Building 900 Metal Awning Structure**

Dear Ms. Joleen,

JJ Global will be complying and is qualified to perform the work required as stipulated in the Original Bid Offering.

Additionally, we thank you for the adjusted two (2) days, we appreciate you.

We have carefully reviewed the SOW; we don't see the specifications about the Building Permit; nowhere on the Bid documents does it reflect and regretfully we're interpreting it differently. Will you kindly provide us the specific paragraph for specifications? Referencing the Building Permit, we had clarified during the Intent of Award, but we never received a response, so we are under the impression that our clarification was permitted.

Lastly but not final, we thank you again for allowing us the opportunity of the extension when/if needed during this pandemic due to weather conditions, and/or due to lack of materials not on island.

We understand this Project is important to GCC and it is important also with us. In humble gratitude and appreciation, thank you for your time and attention.

It's Duly Authorized Representative:

  
KIT CASIN  
Executive Secretary  
JJ GLOBAL SERVICES

Shop Address: 351 Atageta Street, Dededo Guam 96929  
Office Address: 185 Ilipog Drive, Bldg A Suite 203 Harmon Business Center, Tamuning Guam, 96913  
Mailing Address: PO Box 217881, GMF Barrigada Guam 96921  
Tel: (671) 632-1179 Fax: (671) 632-3550  
Email: jjg@teleguam.net

GCC PR0342

**Joleen Evangelista**

---

**From:** Kit Casin <kit.casin@jjglobal.services>  
**Sent:** Tuesday, August 3, 2021 4:25 PM  
**To:** Joleen Evangelista  
**Cc:** Julie Ulloa-Heath; Aileen de Dios; Luis E. Bustaman Miranda; Admin Assistant  
**Subject:** Replacement of Bldg. 900 Metal Awning Structure  
**Attachments:** Awning ltr 08.03.21 for gcc.pdf

8/3/21 JJ Global  
Called Spoke Virginia  
She will relay the  
message to Aileen  
or Kit. m

Hafa Adai Mr. Joleen,

I hope this email finds you well.

Kindly find attached Replacement of Bldg. 900 Metal Awning Structure of contract for your reference.

Please acknowledge receipt of this email.

Should you need further assistance, please do not hesitate to contact us.

Thank you

Best Regards,  
Kit Casin  
*Executive Secretary*



Services

PO Box 217881

GMF Barrigada GU 96921

Tel # 671-633-2603

email: [kit.casin@jjglobal.services](mailto:kit.casin@jjglobal.services)

<http://www.jjglobal.services/>





**JJGlobal**

Facilities Maintenance • Logistics • Construction

**VIA EMAIL**

joleen.evangelista@guamcc.edu

Guam Community College  
**Attn.: Joleen M. Evangelista**  
PO Box 23069  
GMF Barrigada, GU 96921

July 29, 2021

**Re.: Mary Okada's Letter Dated 07/26/2021 for Notice of Bid Award No. GCC-FB-21-009**

Dear Ms. Jolene,

We are grateful and delighted that you have awarded us the Awning Project.

But I must bring to attention that in the Notification of Intent to Award, we clarified that once JJ Global Services acquires the Building Permit from GCC and allotted mobilization time, GCC will then provide the Notice to Proceed Date letter.

Please note the Notice to Proceed Date is dated 07/27/2021 with the deadline to complete this project by October 24, 2021; which I must advise that to date, it has reduced JJ Global Services two (2) days off of the required ninety (90) days completion of project. To date our office has not been furnished with the Building Permit.

I write to state that the Letter Dated 07/26/2021 be rescinded and supplanted with a date that the Notice to Proceed Date can suffice to the date we receive the Building Permit from GCC and the mobilization time. The ninety (90) days completion of project should not be affected by the delay of the non-receipt of the Building Permit.

Your immediate resolution the Notice to Proceed Date is direly needed, as again JJ Global is now two (2) days deficit based on the Notice to Proceed Letter dated 07/26/2021.

Sincerely,

LUIS E. BUSTAMANTE  
C.E.O. / Owner

Shop Address: 351 Alageta Street, Dededo Guam 96929  
Office Address: 185 Ilipog Drive, Bldg A Suite 203 Harmon Business Center, Tamuning Guam, 96913  
Mailing Address: PO Box 217881, GMF Barrigada Guam 96921  
Tel: (671) 632-1179 Fax: (671) 632-3550  
Email: jjg@teleguam.net

GCC PR0344

**Joleen Evangelista**

---

**From:** Kit Casin <kit.casin@jjglobal.services>  
**Sent:** Thursday, July 29, 2021 10:12 AM  
**To:** Joleen Evangelista  
**Cc:** Luis E. Bustamante; Aileen de Dios; Admin Assistant; materialsmanagement@guamcc.edu; Julie Ulloa-Heath; Francisco 'Kiko' Palacios; Josephine.arceo@guamcc.edu; Rodalyn Gerardo; Virginia Tedpahogo; Florenda Miranda  
**Subject:** Re: Bid Award and Contract for GCC-FB-21-009 Replacement of Building 900 Metal Awning Structure  
**Attachments:** GCC Awning in resp to Ntc 2 Proceed Ltr.pdf

Hafa Adai Ms. Joleen,

I hope this email finds you well. Apologies for the late reply.

Kindly find the attached letter of our reply for the said email.  
Please refer to the letter of our response for the notice to proceed.

Please advise.

Should you need further assistance, please do not hesitate to contact us.

Thank you

Best Regards,  
Kit Casin  
*Executive Secretary*



Services  
PO Box 217881  
GMF Barrigada GU 96921  
Tel # 671-633-2603  
email: kit.casin@jjglobal.services  
<http://www.jjglobal.services/>

On Tue, Jul 27, 2021 at 4:46 PM Joleen Evangelista <joleen.evangelista@guamcc.edu> wrote:  
Mr. Bustamante and Ms. De Dios,

GCC is pleased to issue the attached Bid Award letter and contract for the Replacement of Building 900 Metal Awning Structure. Please review and sign the contract and return the signed contract to GCC. The original letter, contract, and PO can be picked up in the Materials Management Office any time between 8 am and 5 pm tomorrow, 7/28/21.

Joleen M. Evangelista

Procurement & Inventory Administrator

**From:** Kit Casin [mailto:[kit.casin@jiglobal.services](mailto:kit.casin@jiglobal.services)]

**Sent:** Tuesday, July 6, 2021 3:44 PM

**To:** Joleen Evangelista [joleen.evangelista@guamcc.edu](mailto:joleen.evangelista@guamcc.edu)

**Cc:** Aileen de Dios <[aileen@jiglobal.services](mailto:aileen@jiglobal.services)>; Luis E. Bustamante <[luis.bustamante34@gmail.com](mailto:luis.bustamante34@gmail.com)>; Admin Assistant <[admin@jiglobal.services](mailto:admin@jiglobal.services)>; Francisco 'Kiko' Palacios <[francisco.palacios1@guamcc.edu](mailto:francisco.palacios1@guamcc.edu)>; Julie Ulloa-Heath <[julie.ulloaheath@guamcc.edu](mailto:julie.ulloaheath@guamcc.edu)>; Huan Hosei <[huan.hosei@guamcc.edu](mailto:huan.hosei@guamcc.edu)>; Rodalyn Gerardo <[rodalyn.gerardo@guamcc.edu](mailto:rodalyn.gerardo@guamcc.edu)>; [materialsmanagement@guamcc.edu](mailto:materialsmanagement@guamcc.edu); Virginia Tedpahogo <[virginia@jiglobal.services](mailto:virginia@jiglobal.services)>; Florenda Miranda <[flor@jiglobal.services](mailto:flor@jiglobal.services)>

**Subject:** Re: Notice of Intent to Award GCC-FB-21-009 Replacement of Building 900 Metal Awning Structure

Hafa Adai Ms. Joleen,

I hope this email finds you well.

Kindly find attached our Acknowledgement of the Notice of Intent to Award for your reference.

Along with a Letter of acknowledgement is our cover letter.

Should you need further assistance, please do not hesitate to contact us.

Thank you

Best Regards,

Kit Casin

*Executive Secretary*

 Services

PO Box 217881

GMF Barrigada GU 96921

Tel # 671-633-2603

email: [kit.casin@jiglobal.services](mailto:kit.casin@jiglobal.services)

<http://www.jiglobal.services/>

On Tue, Jul 6, 2021 at 9:49 AM Joleen Evangelista <[joleen.evangelista@guamcc.edu](mailto:joleen.evangelista@guamcc.edu)> wrote:

Mr. Bustamante, Ms. Casin and JJ Global Administration:

Please note that GCC received an email return from Ms. Aileen de Dios stating that she will be out of the office from July 1, 2021 to August 2, 2021 with limited access to my email. It also indicated to send emails to Ms. Kit Casin and JJ Global Admin. for urgent matters.

Please review the letter and acknowledge receipt ASAP or by 5 pm Tuesday, July 6, 2021 via email to: [materialsmanagement@guamcc.edu](mailto:materialsmanagement@guamcc.edu).

Please provide the required documents requested ASAP or no later than 10 days from the date of the letter otherwise, GCC will not be able to continue with the award.

Please let me know if you have any questions or concerns.

Thank you and Best Regards,

Joleen M. Evangelista  
Procurement & Inventory Administrator

-----Original Message-----

From: Joleen Evangelista [<mailto:joleen.evangelista@guamcc.edu>]

Sent: Friday, July 2, 2021 5:34 PM

To: 'Aileen de Dios' <[aileen@jiglobal.services](mailto:aileen@jiglobal.services)>; 'Luis E. Bustamante' <[luis.bustamante34@gmail.com](mailto:luis.bustamante34@gmail.com)>

Cc: Francisco 'Kiko' Palacios ([francisco.palacios1@guamcc.edu](mailto:francisco.palacios1@guamcc.edu)) <[francisco.palacios1@guamcc.edu](mailto:francisco.palacios1@guamcc.edu)>; 'Julie Ulfoa-Heath'

<julie.ulloaheath@guamcc.edu>; Huan Hosei (huan.hosei@guamcc.edu)  
<huan.hosei@guamcc.edu>; 'Rodalyn Gerardo' <rodalyn.gerardo@guamcc.edu>;  
[materialsmanagement@guamcc.edu](mailto:materialsmanagement@guamcc.edu)

Subject: Notice of Intent to Award GCC-FB-21-009 Replacement of Building 900  
Metal Awning Structure

Mr. Bustamante and Ms. De Dios,

Please see the attached Notice of Intent to Award letter for the  
GCC-FB-21-009 Replacement of Building 900 Metal Awning Structure for Option  
2: Galvanized Iron.

Please review the letter and acknowledge receipt ASAP or by 5 pm Tuesday,  
July 6, 2021 via email to: [materialsmanagement@guamcc.edu](mailto:materialsmanagement@guamcc.edu).

Please provide the required documents requested ASAP or no later than 10  
days from the date of the letter.

Thank you and Best Regards,

Joleen M. Evangelista  
Procurement & Inventory Administrator

—  
  
\_E-mail administered by Guam Community College\_



*E-mail administered by Guam Community College*



*E-mail administered by Guam Community College*

**Joleen Evangelista**

---

**From:** Aileen de Dios <aileen@jjglobal.services>  
**Sent:** Friday, July 16, 2021 3:34 PM  
**To:** joleen.evangelista@guamcc.edu  
**Subject:** Thank you for your message! RE: Notice of Intent to Award GCC-FB-21-009, Replacement of Building 900 Metal Awning Structure; Documents Required

Hafa Adai!

Thank you for your email. I will be out of the office from July 1, 2021 to August 2, 2021 with limited access to my email.

If this is urgent, kindly reach out to:

Kit Casin - Executive Secretary  
[kit.casin@jjglobal.services](mailto:kit.casin@jjglobal.services)  
671.482.9485

Napu Taimanglo - Admin Asst  
[admin@jjglobal.services](mailto:admin@jjglobal.services)  
671.632.1179

I will do my best to follow-up with your concern as soon as I return.

Best regards,  
Aileen

--

*All the best,*

**Aileen de Dios**  
*General Manager*  
<http://www.jjglobal.services/>  
*E: aileen@jjglobal.services*  
*O: 671-632-1179*  
*F: 671-632-3550*

## Joleen Evangelista

---

**From:** virginia@jjglobal.services  
**Sent:** Friday, July 16, 2021 2:57 PM  
**To:** 'Joleen Evangelista'  
**Cc:** 'Aileen de Dios'; 'Luis E. Bustamante'; 'Admin Assistant'; 'Francisco 'Kiko' Palacios'; 'Julie Ulloa-Heath'; 'Huan Hosei'; 'Rodalyn Gerardo'; materialsmanagement@guamcc.edu; 'Florenda Miranda'; 'Kit Casin'  
**Subject:** Notice of Intent to Award GCC-FB-21-009, Replacement of Building 900 Metal Awning Structure; Documents Required  
**Attachments:** Crew Listing.pdf; Bond for GCC Awning Project.pdf; Certificate of Insurance.pdf; Schedule of Values for GCC Awning Project.pdf; Profit Multiplier & CPM Chart for GCC Awning Project.pdf; Contractor's License.pdf  
**Importance:** High

Dear Ms. Joleen,

Find attached per Said Subject Matter.

1. List of Crew (workers) for Project
2. Performance Bond
3. Certificate of Insurance
4. Schedule of Values
5. Overhead and Profit Multiplier
6. CPM Chart
7. Guam Contractor's License

Looking forward to your kind reply. Please acknowledge receipt of this transmission and its attachments. Thank you and be safe.

Sincerely,  
**VIRGINIA M. TEDPAHOGO**  
Collection Administrator  
virginia@jjglobal.services



PO Box 217881 Barrigada, GU 96921  
Telephone Number: 671.632.1179  
Facsimile Number: 671.632.3550  
Website: <http://www.jjglobal.services>

### **CONFIDENTIALITY NOTICE:**

*This electronic message transmission and any attachments to it has been sent for the sole purpose of the intended recipient(s). If you are not an intended recipient, you are hereby notified that any unauthorized dissemination, distribution, or copying of this message, or any attachment, is strictly prohibited. Any use of this information and its attachments, without consent of the sender is punishable by law. Furthermore, the sender does not accept any responsibility for any loss, disruption or damage to your data or computer system that may occur while using data contained in, or transmitted with, this e-mail and its attachments. If you have received this communication in error, please notify the sender and immediately delete or otherwise destroy the original message and all attachments.*

---

**From:** Kit Casin <kit.casin@jjglobal.services>  
**Sent:** Tuesday, July 6, 2021 5:19 PM  
**To:** Joleen Evangelista <joleen.evangelista@guamcc.edu>  
**Cc:** Aileen de Dios <aileen@jjglobal.services>; Luis E. Bustamante <luis.bustamante34@gmail.com>; Admin Assistant <admin@jjglobal.services>; Francisco 'Kiko' Palacios <francisco.palacios1@guamcc.edu>; Julie Ulloa-Heath <julie.ulloaheath@guamcc.edu>; Huan Hosei <huan.hosei@guamcc.edu>; Rodalyn Gerardo <rodalyn.gerardo@guamcc.edu>; materialsmanagement@guamcc.edu; Virginia Tedpahogo <virginia@jjglobal.services>; Florenda Miranda <flor@jjglobal.services>  
**Subject:** Re: Notice of Intent to Award GCC-FB-21-009 Replacement of Building 900 Metal Awning Structure

Hi Ms. Joleen,

Apologies for that. pursuant to my previous email, Kindly find attached our Acknowledgement of the Notice of Intent to Award for your reference.

Along with a Letter of acknowledgement is our cover letter.

Should you need further assistance, please do not hesitate to contact us.

Thank you

Best Regards,  
Kit Casin  
*Executive Secretary*



Services

PO Box 217881  
GMF Barrigada GU 96921  
Tel # 671-633-2603  
email: [kit.casin@jjglobal.services](mailto:kit.casin@jjglobal.services)  
<http://www.jjglobal.services/>

On Tue, Jul 6, 2021 at 5:12 PM Joleen Evangelista <[joleen.evangelista@guamcc.edu](mailto:joleen.evangelista@guamcc.edu)> wrote:

Ms. Kit Casin,

Please note that there are no attachments to this email. Please provide the attachments.



Thank you.

Joleen M. Evangelista

Procurement & Inventory Administrator

**From:** Kit Casin [mailto:[kit.casin@jglobal.services](mailto:kit.casin@jglobal.services)]

**Sent:** Tuesday, July 6, 2021 3:44 PM

**To:** Joleen Evangelista [joleen.evangelista@guamcc.edu](mailto:joleen.evangelista@guamcc.edu)

**Cc:** Aileen de Dios <[aileen@jglobal.services](mailto:aileen@jglobal.services)>; Luis E. Bustamante <[luis.bustamante34@gmail.com](mailto:luis.bustamante34@gmail.com)>; Admin Assistant <[admin@jglobal.services](mailto:admin@jglobal.services)>; Francisco 'Kiko' Palacios <[francisco.palacios1@guamcc.edu](mailto:francisco.palacios1@guamcc.edu)>; Julie Ulloa-Heath <[julie.ulloaheath@guamcc.edu](mailto:julie.ulloaheath@guamcc.edu)>; Huan Hosei <[huan.hosei@guamcc.edu](mailto:huan.hosei@guamcc.edu)>; Rodalyn Gerardo <[rodalyn.gerardo@guamcc.edu](mailto:rodalyn.gerardo@guamcc.edu)>; [materialsmanagement@guamcc.edu](mailto:materialsmanagement@guamcc.edu); Virginia Tedpahogo <[virginia@jglobal.services](mailto:virginia@jglobal.services)>; Florenda Miranda <[flor@jglobal.services](mailto:flor@jglobal.services)>

**Subject:** Re: Notice of Intent to Award GCC-FB-21-009 Replacement of Building 900 Metal Awning Structure

Hafa Adai Ms. Joleen,

I hope this email finds you well.

Kindly find attached our Acknowledgement of the Notice of Intent to Award for your reference.

Along with a Letter of acknowledgement is our cover letter.

Should you need further assistance, please do not hesitate to contact us.

Thank you

Best Regards,

Kit Casin

*Executive Secretary*



Services

PO Box 217881

GMF Barrigada GU 96921

Tel # 671-633-2603

email: [kit.casin@jglobal.services](mailto:kit.casin@jglobal.services)

<http://www.jglobal.services/>

On Tue, Jul 6, 2021 at 9:49 AM Joleen Evangelista <[joleen.evangelista@guamcc.edu](mailto:joleen.evangelista@guamcc.edu)> wrote:

Mr. Bustamante, Ms. Casin and JJ Global Administration:

Please note that GCC received an email return from Ms. Aileen de Dios stating that she will be out of the office from July 1, 2021 to August 2, 2021 with limited access to my email. It also indicated to send emails to Ms. Kit Casin and JJ Global Admin. for urgent matters.

Please review the letter and acknowledge receipt ASAP or by 5 pm Tuesday, July 6, 2021 via email to: [materialsmanagement@guamcc.edu](mailto:materialsmanagement@guamcc.edu).

Please provide the required documents requested ASAP or no later than 10 days from the date of the letter otherwise, GCC will not be able to continue with the award.

Please let me know if you have any questions or concerns.

Thank you and Best Regards,

Joleen M. Evangelista  
Procurement & Inventory Administrator

-----Original Message-----

From: Joleen Evangelista [mailto:[joleen.evangelista@guamcc.edu](mailto:joleen.evangelista@guamcc.edu)]  
Sent: Friday, July 2, 2021 5:34 PM  
To: 'Aileen de Dios' <[aileen@jglobal.services](mailto:aileen@jglobal.services)>; 'Luis E. Bustamante' <[luis.bustamante34@gmail.com](mailto:luis.bustamante34@gmail.com)>

Cc: Francisco 'Kiko' Palacios ([francisco.palacios1@guamcc.edu](mailto:francisco.palacios1@guamcc.edu))  
<[francisco.palacios1@guamcc.edu](mailto:francisco.palacios1@guamcc.edu)>; 'Julie Ulloa-Heath'  
<[julie.ulloaheath@guamcc.edu](mailto:julie.ulloaheath@guamcc.edu)>; Huan Hosei ([huan.hosei@guamcc.edu](mailto:huan.hosei@guamcc.edu))  
<[huan.hosei@guamcc.edu](mailto:huan.hosei@guamcc.edu)>; 'Rodaly Gerardo' <[rodalyn.gerardo@guamcc.edu](mailto:rodalyn.gerardo@guamcc.edu)>;  
[materialsmanagement@guamcc.edu](mailto:materialsmanagement@guamcc.edu)  
Subject: Notice of Intent to Award GCC-FB-21-009 Replacement of Building 900  
Metal Awning Structure

Mr. Bustamante and Ms. De Dios,

Please see the attached Notice of Intent to Award letter for the  
GCC-FB-21-009 Replacement of Building 900 Metal Awning Structure for Option  
2: Galvanized Iron.

Please review the letter and acknowledge receipt ASAP or by 5 pm Tuesday,  
July 6, 2021 via email to: [materialsmanagement@guamcc.edu](mailto:materialsmanagement@guamcc.edu).

Please provide the required documents requested ASAP or no later than 10  
days from the date of the letter.

Thank you and Best Regards,

Joleen M. Evangelista  
Procurement & Inventory Administrator

--

\_E-mail administered by Guam Community College\_



*E-mail administered by Guam Community College*



**July 2021 Crew for GCC Metal Awning Structure**

EMPLOYEE NAME	DATE OF BIRTH
Sergei Khrustalev ✓	04.04.1973
Frank Flores ✓	11.04.1956
Aleksandr Ruchkuvskii ✓	07.11.1999
Rustam Eshanuv ✓	05.15.1981
Ken Mangamaw ✓	06.21.1981
Sean Dulei ✓	02.18.1987
Francis Goray ✓	12.04.1990
Justin Benavente ✓	04.29.1997
Agape Lodge ✓	11.20.1990
Attom Atty ✓	04.04.1997
Isa Thimoty ✓	05.26.1998
Rockson Kete ✓	08.28.1984
Jonathan Taijeron ✓	06.29.1997
Jonatha Agualada ✓	11.19.1996
Christian Gumataotao ✓	07.13.2001
Graig Marsono ✓	05.02.2001
Gregory James ✓	04.01.2000
A.S. Miochy ✓	10.07.2002
Paul Miochy ✓	04.10.1998
Pedro (YG) Graceful ✓	08.13.1997

*All clear.  
7/16/2021  
RKH*

Shop Address: 351 Alageta Street, Dededo Guam 96929  
 Office Address: 185 Ilipog Drive, Bldg A Suite 203 Harmon Business Center, Tamuning Guam, 96913  
 Mailing Address: PO Box 217881, GMF Barrigada Guam 96921  
 Tel: (671) 632-1179 Fax: (671) 632-3550  
 Email: jjg@teleguam.net

# PERFORMANCE BOND

BOND NO. 2021015

Luis E. Bustamante dba: JJ Global Services

KNOW ALL MEN BY THESE PRESENTS that PO Box 217881 GMF, Barrigada, Guam 96921 (insert full name and address or legal title of Contractor) as Principal, hereinafter called Contractor; and (Surety), a duly admitted insurer under the laws of the Territory of Guam as Surety, hereinafter called Surety, are held and firmly bound unto Guam Community College as Oblige, in the amount of One Hundred Sixty Three Thousand Two Hundred Sixty Three and 84/100 Dollars (\$ 163,263.84) for the payment whereof Contractor and Surety bind themselves, their heirs, executors, administrators, successors and assigns, jointly and severally, firmly by these presents.

WHEREAS, Contractor has by written agreement dated July 2, 20 21, entered into a contract with Guam Community College for GCC-FB-21-009 Replacement of Building 900 Metal Awning Structure in accordance with drawings and specifications prepared by (insert full name and address or legal title of architect) \_\_\_\_\_ which contract is by reference made a part of hereof, and is hereinafter referred to as the Contract.

NOW, THEREFORE, THE CONDITION OF THIS OBLIGATION is such that, if Contractor shall promptly and faithfully perform said Contract then this obligation shall be null and void; otherwise it shall remain in full force and effect. The Surety hereby waives notice of any alteration or extension provided the same is within the scope of the Contract. Whenever Contractor shall be and is declared by Guam Community College to be in default under the Contract, Guam Community College having performed GCC obligations thereunder, the Surety may promptly remedy the default or shall promptly:

1. Complete the Contract in accordance with its terms and obligations; or
2. Obtain a bid or bids for completing the Contract in accordance with its terms and conditions, and upon determination by Guam Community College and the Surety jointly of the lowest responsive, responsible bidder, arrange for a contract (between such bidder and Guam Community College and make available as work progresses (even though there should be a default or a succession of defaults under the contract or contracts of completion arranged under this paragraph) sufficient funds to pay the cost of completion less the balance of the contract price; but not exceeding, including other costs and damages for which the Surety may be liable hereunder, the amount set forth in the first paragraph hereof. The term "balance of the contract price," as used in this paragraph shall mean the total amount payable by Guam Community College to the Contractor under the Contract and any amendments thereto, less the amount properly paid by the Guam Community College to the Contractor. No right of action shall accrue on this bond to or for the use of any person or corporation other than Guam Community College or successors of Guam Community College.

Signed and sealed this 13th day of July, 20 21

Luis E. Bustamante  
dba: JJ Global Services

(Principal)

(Seal)

(Witness) \_\_\_\_\_

(Title) \_\_\_\_\_

(Surety)  \_\_\_\_\_

(Title) CSA \_\_\_\_\_

Aioi Nissay Dowa Insurance Company Ltd.  
(Bonding Company)

  
Jo Takagi, Attorney-In-Fact  
(Title)

BY:

Takagi & Associates, Inc.  
(Resident General Agent)

**POWER OF ATTORNEY**

**KNOW ALL MEN BY THESE PRESENTS**

That **AIOI NISSAY DOWA INSURANCE COMPANY LTD.**, a corporation of the State of Japan, having its principal office in the city of Tokyo, Japan, does hereby appoint, **HIDENOBU TAKAGI, JO TAKAHI, MALCOLM A. CREDE, ALL OF THE CITY OF TOMON, GUAM**, its true and lawful attorney, with full authority to execute on its behalf as surety, bonds, undertakings and contracts of suretyship thereof issued in the course of its business and to bind the Company thereby, in an amount not to exceed \$\*\*\*10,000,000Dollars\*\*\*.

This Power of Attorney is granted and is signed and sealed by facsimile under and by the authority of the following Resolution adopted by the Board of Directors of the Company on the 11th day of September 1999.

**RESOLVED**, that the President, an Executive Vice President or a Senior Managing Director or a Managing Director or an Associate Director of the Company, shall have the power and authority to appoint Attorney and to authorize them to execute on behalf of the Company and attach the seal of the Company hereto to surety, bonds, undertakings and contracts of suretyship.

**RESOLVED FURTHER**, that the signatures of such Directors and the seal of the Company may be affixed to any such Power of Attorney or certificate relating thereto, by facsimile, and any such Power of Attorney or certificate bearing such facsimile signatures or facsimile seal shall be valid and binding upon the Company in the future with respect to any surety, bonds, undertakings and contracts of suretyship."

I, **Hideaki Matsui**, being duly sworn, depose and say that I am the Executive Officer of **Aioi Nissay Dowa Insurance Company Limited** and that this Power of Attorney set forth herein is true and correct to the best of my information, knowledge and belief.



**Hideaki Matsui**  
Executive Officer

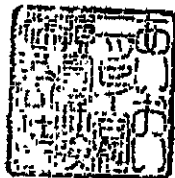

Subscribed and sworn before me this 11th day of July, 2017

I, Stewart Minto, being duly sworn, depose and say that I am the General Manager of All Nifty Data Insurance Company Limited and that this Power of Attorney set forth herein is true and correct to the best of my information, knowledge and belief.

  
Stewart Minto  
General Manager  
All Nifty Data Insurance Company Limited



Subscribed and sworn before me this 14th day of July, 2017.

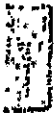

**NOTARIAL CERTIFICATE**

This is to certify that Kei Nemoto, an agent of Hideshi Matsui,  
Executive Officer of Aioi Nissay Dowa Insurance Co., Ltd., and  
Hirovuki Muto, General Manager of International Department of  
Aioi Nissay Dowa Insurance Co., Ltd., have stated in my presence that  
the said Hideshi Matsui and Hirovuki Muto acknowledged themselves  
to have signed on the attached document.

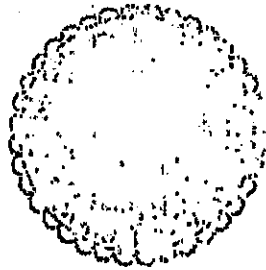

JUL 21 1987

*Kayoko Kohida* 

TOKYO  
JAPAN



GCC PROJECT	2ND BILLING	3RD BILLING	4TH	RETAINER	TOTAL
	100% OF MATERIALS				
MOBILIZATION/ PLANS/ DESIGN					24,528.68
INSURANCE BOND/ BUILDERS RISK					5,972.15
MATERIAL COSTS	40,525.30				40,525.30
REMOVAL & DISPOSAL					6,750.66
LABOR COST INSTALLATION NEW METAL					
COLUMNS, CABLE BRACING		36,323.46			36,323.46
INSTALLATION NEW PURLINS		5,758.86			5,758.86
NEW RAFTER SYSTEM			8,531.64		8,531.64
CORROGATED ROOF WITH SEALANT			14,397.14		14,397.14
PAINTING			3,199.37		3,199.37
REMOVAL/INSTALLATION OF ADDL TOOLS			950.21		950.21
RETAINAGE- 10%				16,326.38	16,326.38
	40,525.30	42,082.31	27,078.36	16,326.38	163,763.84

Project: Awning Project  
 Subject: Construction Schedule (MCD Project Managers)

Items	Activity Description (MCD)	Duration (Days)	WK 1	WK 2	WK 3	WK 4	WK 5	WK 6	WK 7	WK 8	WK 9	WK 10	WK 11	WK 12	WK 13	WK 14	WK 15
1	Application for Building Permit	14															
2	Mobilization	3															
3	Demolition	11															
4	Disposal of demolished items (Phase 1)	7															
5	Disposal of demolished items (Phase 2)	7															
6	Rectification of Foundation/Footings	4															
7	Fabrication of Columns and Beams	17															
8	Installation of Columns	6															
9	Installation of Beams	6															
10	Installation of Channel Beams	6															
11	Installation of Suspended Cables	5															
12	Fascia butler and new purtins	7															
13	Installation of Gutter	11															
14	Installation Cirrugated roof sheet panels	11															
15	Installation of Down spall	5															
16	Electrical Works	11															
17	Re-installation of removed items	15															
18	Painting works	9															
19	Production and Submission of As-built plans	7															
20	Demobilization	10															



Date: 16<sup>th</sup> July 2021

VIA HAND-DELIVER

To: Guam Community College  
ATTN.: GCC Materials Management Office  
Room 2104  
Mangilao, Guam

GCC Bid No. GCC-FB-21-009  
Bid Description: Replacement of Building 900 Metal Awning Structure, Required Documents

Please find per the directive of Joleen M. Evangelista / Procurement & Inventory Administrator, the following Contents.

- List of Workers
- Performance Bond
- Certificate of Insurance
- Schedule of Values
- Overhead and Profit Multiplier / CPM Chart
- Contractor's License

Delivered By: *Akremio Conde Jr.*  
PRINT and SIGN

Date Delivered: *07/19/21*

Guam Community Collg.  
MATERIAL MANAGEMENT  
RECEIVED

JUL 19 2021 10:23 AM

Initials: *JEM*  
Forwarded to: \_\_\_\_\_  
Date Forwarded: \_\_\_\_\_

Shop Address: 351 Alageta Street, Dededo Guam 96929  
Office Address: 185 Ilipog Drive, Bldg A Suite 203 Harmon Business Center, Tamuning Guam, 96913  
Mailing Address: PO Box 217881, GMF Barrigada Guam 96921  
Tel: (671) 632-1179 Fax: (671) 632-3550  
Email: jjg@teleguam.net



**JJGlobal**

*Facilities Maintenance • Logistics • Construction*

July 6, 2021

Ms. Joleen M. Evangelista  
Procurement & Inventory Administrator

Please be aware that we are in receipt of the Notice of Intent to Award just this morning, 07/06/2021 at about 8:14am. This was sent to us past our normal business hours, which was after 5pm last week Friday, 07/02/2021. Please note, all staff were Off Duty during the weekend and in addition to the Federal Holiday on Monday, 07/05/2021. JJ Global Services immediately initiated action on working to fulfill the required document(s); however, JJ we will need ten (10) working days from the date of receipt to comply with the documentation needed

and not 10 days from the date of the Award Letter.

The 90 days as we confirm on the clarification letter, will be dependent on weather conditions. JJ Global will maintain a record of these unforeseen weather conditions and will submit an extension to GCC on the 90 days grant of extension, or if any natural disaster(s) that will hinder the project from continuing w/in the time frame of 90 days. In addition, JJ Global will submit an extension as well for any delay in materials if not located on island.

Once GCC furnishes the Building Permit to JJ Global, it will give 36 hours allotment before the Notice to Proceed Date for the mobilization time and schedule implementation of our crew.

Should you have further any question or concern you may contact me or Kit Casin 482-9485.

Thank you

Very Respectfully Yours,

Luis E Bustamante  
CEO

Physical Address: 215 Rojas Street, Suite 126 Harmon Industrial Park, Tamuning Guam, 96913  
Mailing Address: PO Box 217881, GMF Barrigada Guam 96921  
Tel: (671) 632-1179 Fax: (671) 632-3550  
Email: [jjg@teleguam.net](mailto:jjg@teleguam.net)

**GCC PR0373**



July 2, 2021

To: JJ Global Services  
P.O. Box 217881 GMF  
Barrigada, Guam 96921

Attn: Mr. Luis Bustamante  
CEO

Ms. Aileen de Dios  
General Manager

Subject: Notice of Intent to Award  
GCC Bid No: GCC-FB-21-009  
Bid Description: Replacement of Building 900 Metal Awning Structure

Dear Mr. Bustamante and Ms. De Dios,

GCC has reviewed and evaluated your bid submission and intends to award JJ Global Services, JJ's bid is deemed the lowest, responsive and responsible. GCC intends to award Option 2; Galvanized Iron for this project in the amount of \$163,263.84.

Prior to providing you with the contract, JJ Global Services will need to submit the following documents:

1. The list of workers that will be assigned to this project so that GCC can clear them off the sex offender registry. Please provide their full legal name and Date of Birth.
2. Performance Bond in the amount of one-hundred percent (100%) of the contract price. The bond shall be in accordance with Item 18 of the General Terms and Conditions of this bid.
3. Certificate of Insurance showing proof of Contractor's Liability Insurance
4. Listing of subcontractors- if none, please indicate; if there are subcontractors, please provide the contractor's name and full legal name and Date of birth of the subcontractor's employees that will be assigned to this project.
5. Schedule of Values
6. Overhead and Profit Multiplier (Isolated)
7. Updated CPM Chart
8. Copy of your current Guam Contractor's license.

The project completion time is 90 consecutive calendar days upon the Notice to Proceed date.

Please provide the information and documents requested ASAP or no later than 10 days from the date of this letter. Once the requested documents are submitted, GCC will contact you to pick up the contract/PO and will schedule a post-award meeting.

GCC thanks you in participating in this bid and looks forward to working with you.

Sincerely,

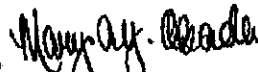
  
Mary Aly Okada, Ed.D.  
President

Ackn  
Recvd. by Luis E. Bustamante  
July 06, 2021  
Time 8:14 pm



**JJGlobal**

Facilities Maintenance • Logistics • Construction

July 6, 2021

Ms. Joleen M. Evangelista  
Procurement & Inventory Administrator

Please be aware that we are in receipt of the Notice of Intent to Award just this morning, 07/06/2021 at about 8:14am. This was sent to us past our normal business hours, which was after 5pm last week Friday, 07/02/2021. Please note, all staff were Off Duty during the weekend and in addition to the Federal Holiday on Monday, 07/05/2021. JJ Global Services immediately initiated action on working to fulfill the required document(s); however, JJ we will need ten (10) working days from the date of receipt to comply with the documentation needed

and not 10 days from the date of the Award Letter.

The 90 days as we confirm on the clarification letter, will be dependent on weather conditions. JJ Global will maintain a record of these unforeseen weather conditions and will submit an extension to GCC on the 90 days grant of extension, or if any natural disaster(s) that will hinder the project from continuing w/in the time frame of 90 days. In addition, JJ Global will submit an extension as well for any delay in materials if not located on island.

Once GCC furnishes the Building Permit to JJ Global, it will give 36 hours allotment before the Notice to Proceed Date for the mobilization time and schedule implementation of our crew.

Should you have further any question or concern you may contact me or Kit Casin 482-9485.

Thank you

Very Respectfully Yours,

Luis E Bustamante  
CEO

Physical Address: 215 Rojas Street, Suite 126 Harmon Industrial Park, Tamuning Guam, 96913  
Mailing Address: PO Box 217881, GMF Barrigada Guam 96921  
Tel: (671) 632-1179 Fax: (671) 632-3550  
Email: jjg@teleguam.net

GCC PR0375



**JJGlobal**

Facilities Maintenance • Logistics • Construction

**July 2021 Crew for GCC Metal Awning Structure**

EMPLOYEE NAME	DATE OF BIRTH
Sergei Khrustalev	04.04.1973
Frank Flores	11.04.1956
Aleksandr Ruchkuvskii	07.11.1999
Rustam Eshanuv	05.15.1981
Ken Mangamaw	06.21.1981
Sean Dulei	02.18.1987
Francis Goray	12.04.1990
Justin Benavente	04.29.1997
Agape Lodge	11.20.1990
Attom Atty	04.04.1997
Isa Thimoty	05.26.1998
Rockson Kete	08.28.1984
Jonathan Taijeron	06.29.1997
Jonatha Agualada	11.19.1996
Christian Gumataotao	07.13.2001
Graig Marsono	05.02.2001
Gregory James	04.01.2000
A.S. Miochy	10.07.2002
Paul Miochy	04.10.1998
Pedro (YG) Graceful	08.13.1997

Shop Address: 351 Alageta Street, Dededo Guam 96929  
Office Address: 185 Ilipog Drive, Bldg A Suite 203 Harmon Business Center, Tamuning Guam, 96913  
Mailing Address: PO Box 217881, GMF Barrigada Guam 96921  
Tel: (671) 632-1179 Fax: (671) 632-3550  
Email: jjg@teleguam.net

GCC PR0376

# PERFORMANCE BOND

BOND NO. 2021015

Luis E. Bustamante dba: JJ Global Services

KNOW ALL MEN BY THESE PRESENTS that PO Box 217881 GMF, Barrigada, Guam 96921 (Insert full name and address or legal title of Contractor) as Principal, hereinafter called Contractor, and (Surety), a duly admitted insurer under the laws of the Territory of Guam as Surety, hereinafter called Surety, are held and firmly bound unto Guam Community College as Oblige, in the amount of One Hundred Sixty Three Thousand Two Hundred Sixty Three and 84/100 Dollars (\$ 163,263.84) for the payment whereof Contractor and Surety bind themselves, their heirs, executors, administrators, successors and assigns, jointly and severally, firmly by these presents.

WHEREAS, Contractor has by written agreement dated, July 2, 2021, entered into a contract with Guam Community College for GCC-FB-21-009 Replacement of Building 900 Metal Awning Structure in accordance with drawings and specifications prepared by (insert full name and address or legal title of architect) \_\_\_\_\_ which contract is by reference made a part of hereof, and is hereinafter referred to as the Contract.

NOW, THEREFORE, THE CONDITION OF THIS OBLIGATION is such that, if Contractor shall promptly and faithfully perform said Contract then this obligation shall be null and void; otherwise it shall remain in full force and effect. The Surety hereby waives notice of any alteration or extension provided the same is within the scope of the Contract. Whenever Contractor shall be and is declared by Guam Community College to be in default under the Contract, Guam Community College having performed GCC obligations thereunder, the Surety may promptly remedy the default or shall promptly:

1. Complete the Contract in accordance with its terms and obligations; or
2. Obtain a bid or bids for completing the Contract in accordance with its terms and conditions, and upon determination by Guam Community College and the Surety jointly of the lowest responsive, responsible bidder, arrange for a contract (between such bidder and Guam Community College and make available as work progresses (even though there should be a default or a succession of defaults under the contract or contracts of completion arranged under this paragraph) sufficient funds to pay the cost of completion less the balance of the contract price; but not exceeding, including other costs and damages for which the Surety may be liable hereunder, the amount set forth in the first paragraph hereof. The term "balance of the contract price," as used in this paragraph shall mean the total amount payable by Guam Community College to the Contractor under the Contract and any amendments thereto, less the amount properly paid by the Guam Community College to the Contractor. No right of action shall accrue on this bond to or for the use of any person or corporation other than Guam Community College or successors of Guam Community College.

Signed and sealed this 13th day of July, 2021. Luis E. Bustamante  
dba: JJ Global Services

\_\_\_\_\_  
(Principal) (Seal)

(Witness) \_\_\_\_\_

(Title) \_\_\_\_\_

(Surety) [Signature] \_\_\_\_\_

(Title) CSA \_\_\_\_\_

Aioi Nissay Dowa Insurance Company Ltd.

\_\_\_\_\_  
(Bonding Company)

Jo Takagi, Attorney-In-Fact

\_\_\_\_\_  
(Title)

BY:

Takagi & Associates, Inc.

\_\_\_\_\_  
(Resident General Agent)



**POWER OF ATTORNEY**

**KNOW ALL MEN BY THESE PRESENTS**

That AIOI NISSAY DOWA INSURANCE COMPANY LTD., a corporation of the State of Japan, having its principal office in the city of Tokyo, Japan, does hereby appoint, HIDENOBU TAKAGI, JO TAKAGI, PAMELA A. CEJUE, ALL OF THE CITY OF TUMON, GUAM, its true and lawful attorney, with full authority to execute on its behalf as surety, bonds, undertakings and contracts of suretyship thereof, issued in the course of its business and to bind the Company thereby, in an amount not to exceed \$\*\*\*10,000,000Dollars\*\*\*.

This Power of Attorney is granted and is signed and sealed by facsimile under and by the authority of the following Resolution adopted by the Board of Directors of the Company on the 21st day of September 1990.

RESOLVED, that the President, an Executive Vice President or a Senior Managing Director or a Managing Director or an Associate Director of the Company, shall have the power and authority to appoint Attorney and to authorize them to execute on behalf of the Company and attach the seal of the Company hereto to surety, bonds, undertakings and contracts of suretyship.

RESOLVED FURTHER, that the signatures of such Directors and the seal of the Company may be affixed to any such Power of Attorney or certificate relating thereto, by facsimile, and any such Power of Attorney or certificate bearing such facsimile signatures or facsimile seal shall be valid and binding upon the Company in the future with respect to any surety, bonds, undertakings and contracts of suretyship."

I, Hideaki Matsui, being duly sworn, depose and say that I am the Executive Officer of Aioi Nissay Dowa Insurance Company Limited and that this Power of Attorney set forth herein is true and correct to the best of my information, knowledge and belief.



Hideaki Matsui  
Executive Officer

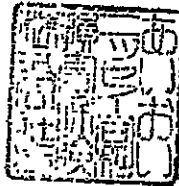

Subscribed and sworn before me this 13th day of July, 2017

I, Ebrahim Mulla, being duly sworn, depose and say that I am the General Manager of AIG Niassy Dowry Insurance Company Limited and that this Power of Attorney set forth herein is true and correct to the best of my information, knowledge and belief.

  
Ebrahim Mulla  
General Manager  
International Department



Subscribed and sworn before me this 18<sup>th</sup> day of July, 2017

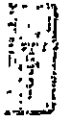

**NOTARIAL CERTIFICATE**

This is to certify that Kei Nemoto, an agent of Hideshi Matsui,  
Executive Officer of Aioi Nissay Dowa Insurance Co., Ltd., and  
Hiroyuki Muto, General Manager of International Department of  
Aioi Nissay Dowa Insurance Co., Ltd., have stated in my presence that  
the said Hideshi Matsui and Hiroyuki Muto acknowledged themselves  
to have signed on the attached document.

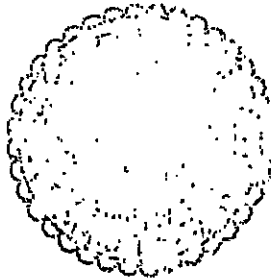

JUL 24 2017

*Haruhiko Ohida*

NOTARY PUBLIC  
JAPAN

平成29年登録第

712

証

嘱託人あいおいニッセイ同和損害保険株式会社 執行役員 松井秀司 及び 同  
国際業務部長 武藤康之の代理人 根木圭は、本状に対し、松井秀司及び武藤康之  
が添付裏面の署名につき、各々自らしたものであることを承認する旨陳述した。

よって、これを認証する。

平成29年 7月 21日、本公証人役場において

東京都中央区八重洲1丁目7番20号

東京法務局所属

公証人  
Notary

石田一宏

Kazuhiro ISHIDA

証 明

上記署名は、東京法務局所属公証人の署名に相当ないものであり、かつ、その押印は、  
真実のものであることを証明する。

平成29年 7月 21日

東京法務局長

秋山仁美

APOSTILLE

(Convention de La Haye du 5 octobre 1961)

1. Country: JAPAN

This public document

2. has been signed by Kazuhiro ISHIDA

3. acting in the capacity of Notary of the Tokyo Legal Affairs Bureau

4. bears the seal/stamp of Kazuhiro ISHIDA, NOTARY

Certified

5. at Tokyo

6. JUL 21, 2017

7. by the Ministry of Foreign Affairs

8. ID No 052531

9. Seal/stamp:

10. Signature

T. TANAKA

Toshie TANAKA

For the Minister for Foreign Affairs

**GOVERNMENT OF GUAM**  
**DEPARTMENT OF REVENUE AND TAXATION**  
**OFFICE OF THE BANKING AND INSURANCE COMMISSIONER**  
**CERTIFICATE OF AUTHORITY**

RENEWAL                      COA272

*Know All Men By These Presents That:*

**Name**      **AIOI NISSAY DOWA INSURANCE COMPANY LIMITED**

**Address**    1-28-1, EBISU,                      SHIBUYA-KU  
                  TOKYO, 150-8488 JAPAN,      --

<b>Classes of Insurance Authorized</b>	}	Accident & Health	Motor Vehicle
		Fidelity & Surety	Prop. Damage & Liability
		Fire	Workmens Comp
		Marine	
		Miscellaneous	

*Having complied with the Insurance Law of Guam, is hereby authorized to transact as an insurer, the above named Classes of Insurance in Guam from the 1st day of July, 2021 to the 1st day of July, 2022 unless authority is revoked for failure to comply with the law.*

**General Agent(s):**  
TAKAGI & ASSOCIATES INC

*In Witness Whereof, I have hereunto subscribed my name officially and have hereon impressed my Seal of Office at the City of Hagaña, Guam on this 1st day of July, 2021*

  
**MICHELLE B. SANTOS**  
Banking & Insurance Commissioner

# CERTIFICATE OF INSURANCE

Cert#: 20105

ISSUE DATE (MM/DD/YY)  
Jul 13 2021

**PRODUCER**  
Takagi & Associates, Inc.  
540 Pate San Vitores Road Ste. 200  
Flame Tree Plaza  
TAMUNING Guam 96913-4075

THIS CERTIFICATE IS ISSUED AS A MATTER OF INFORMATION ONLY AND CONFERS NO RIGHTS UPON THE CERTIFICATE HOLDER. THIS CERTIFICATE DOES NOT AMEND, EXTEND OR ALTER THE COVERAGE AFFORDED BY THE POLICIES BELOW.

### COMPANIES AFFORDING COVERAGE

COMPANY LETTER	A Aiol Nissay Down Insurance Company, Limited
COMPANY LETTER	
COMPANY LETTER	
COMPANY LETTER	

**INSURED** Bustamante, Luis E. DBA JJ Janitorial Service  
DBA JJ International Services DBA JJ Global Services  
P.O. Box 217881  
BARRIGADA Guam 96921-6956

### COVERAGES

THIS IS TO CERTIFY THAT THE POLICIES OF INSURANCE LISTED BELOW HAVE BEEN ISSUED TO THE INSURED NAMED ABOVE FOR THE POLICY PERIOD INDICATED, NOTWITHSTANDING ANY REQUIREMENT, TERM OR CONDITION OF ANY CONTRACT OR OTHER DOCUMENT WITH RESPECT TO WHICH THIS CERTIFICATE MAY BE ISSUED OR MAY PERTAIN, THE INSURANCE AFFORDED BY THE POLICIES DESCRIBED HEREIN IS SUBJECT TO ALL THE TERMS, EXCLUSIONS AND CONDITIONS OF SUCH POLICIES.

INSR LTR	TYPE OF INSURANCE	ADDL INSR	SUBR WVD	POLICY NUMBER	POLICY EFF (MM/DD/YYYY)	POLICY EXP (MM/DD/YYYY)	LIMITS	
A	<b>GENERAL LIABILITY</b>			BOP-00225	Mar 10 2021	Mar 10 2022	BODILY INJURY OCC	\$
	<input checked="" type="checkbox"/> COMPREHENSIVE FORM						BODILY INJURY AGG	\$
	<input checked="" type="checkbox"/> PREMISES/OPERATIONS						PROPERTY DAMAGE OCC	\$
	<input checked="" type="checkbox"/> UNDERGROUND EXPLOSION & COLLAPSE HAZARD						PROPERTY DAMAGE AGG	\$
	<input checked="" type="checkbox"/> PRODUCTS/COMPLETED OPER.	X					BI & PD COMBINED OCC	\$ 2,000,000
	<input checked="" type="checkbox"/> CONTRACTUAL						BI & PD COMBINED AGG	\$ 2,000,000
	<input checked="" type="checkbox"/> INDEPENDENT CONTRACTORS						BROAD FORM AGG	\$ Included
	<input checked="" type="checkbox"/> BROAD FORM CGL						PERSONAL INJURY AGG	\$ Included
A	<b>AUTOMOBILE LIABILITY</b>			BAP-00536	Mar 10 2021	Mar 10 2022	BODILY INJURY (Per Person)	\$
	<input type="checkbox"/> ANY AUTO						BODILY INJURY (Per Accident)	\$
	<input type="checkbox"/> ALL OWNED AUTOS (Priv Pass)						PROPERTY DAMAGE	\$
	<input type="checkbox"/> ALL OWNED AUTO (Other than Priv Pass)	X					BODILY INJURY & PROPERTY DAMAGE COMBINED	\$ 2,000,000
	<input checked="" type="checkbox"/> HIRED AUTOS							
	<input checked="" type="checkbox"/> NON-OWNED AUTOS							
A	<b>WORKER'S COMPENSATION AND EMPLOYERS' LIABILITY</b>			BOP-00225	Mar 10 2021	Mar 10 2022	STATUTORY LIMITS	Guam PL-80
							EACH ACCIDENT	\$ 500,000
							DISEASE-POLICY LIMIT	\$ 500,000
							DISEASE-EACH EMPLOYEE	\$ 500,000
	<b>OTHER</b>							

**DESCRIPTION OF OPERATIONS/LOCATIONS/VEHICLES/SPECIAL ITEMS**

Effective 7/13/21 Guam Community College is named as Additional Insured to the above General Liability and Automobile Liability policies, with respect to the following project:  
**Project: Replacement of Building 900 Metal Awning Structure**  
**GCC Bid No.: GCC-FB-21-009**

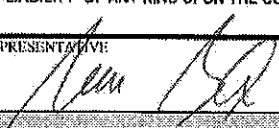
<b>CERTIFICATE HOLDER</b>	<b>CANCELLATION</b>
Guam Community College P.O. Box 23069 BARRIGADA Guam 96921	SHOULD ANY OF THE ABOVE DESCRIBED POLICIES BE CANCELLED BEFORE THE EXPIRATION DATE THEREOF, THE ISSUING COMPANY WILL ENDEAVOR TO MAIL 30 DAYS WRITTEN NOTICE TO THE CERTIFICATE HOLDER NAMED TO THE LEFT BUT FAILURE TO MAIL SUCH NOTICE SHALL IMPOSE NO OBLIGATION OR LIABILITY OF ANY KIND UPON THE COMPANY, ITS AGENTS OR REPRESENTATIVES.
	AUTHORIZED REPRESENTATIVE 

**GCC PR0383**

GCC PROJECT	AMOUNT	OVERHEAD	PROFIT	GRT	TOTAL	1ST BILLING
		5%	7.60%	5.9%		
MOBILIZATION/ PLANS/ DESIGN	23,000.00	\$ 1,150.00	1,748.00	1,356.09	27,254.09	24,528.68
INSURANCE BOND/ BUILDERS RISK	5,600.00	\$ 280.00	425.60	330.12	6,635.72	5,972.15
MATERIAL COSTS	38,000.00	\$ 1,900.00	2,888.00	2,240.10	45,028.10	
REMOVAL & DISPOSAL	6,330.00	\$ 316.50	481.08	373.15	7,500.73	6,750.66
LABOR COST INSTALLATION NEW METAL						
COLUMNS, CABLE BRACING	34,060.00	\$ 1,703.00	2,588.56	2,007.84	40,359.40	
INSTALLATION NEW PURLINS	5,400.00	\$ 270.00	410.40	318.33	6,398.73	
NEW RAFTER SYSTEM	8,000.00	\$ 400.00	608.00	471.60	9,479.60	
CORROGATED ROOF WITH SEALANT	13,500.00	\$ 675.00	1,026.00	795.83	15,996.83	
PAINTING	3,000.00	\$ 150.00	228.00	176.85	3,554.85	
REMOVAL/INSTALLATION OF ADDL TOOLS	891.00	\$ 44.55	67.72	52.52	1,055.79	
RETAINAGE- 10%						
	137,781.00	6,889.05	10,471.36	8,122.43	163,263.84	37,251.49

GCC PROJECT	2ND BILLING	3RD BILLING	4TH	RETAINER	TOTAL
	100% OF MATERIALS				
MOBILIZATION/ PLANS/ DESIGN					24,528.68
INSURANCE BOND/ BUILDERS RISK					5,972.15
MATERIAL COSTS	40,525.30				40,525.30
REMOVAL & DISPOSAL					6,750.66
LABOR COST INSTALLATION NEW METAL					
COLUMNS, CABLE BRACING		36,323.46			36,323.46
INSTALLATION NEW PURLINS		5,758.86			5,758.86
NEW RAFTER SYSTEM			8,531.64		8,531.64
CORROGATED ROOF WITH SEALANT			14,397.14		14,397.14
PAINTING			3,199.37		3,199.37
REMOVAL/INSTALLATION OF ADDL TOOLS			950.21		950.21
RETAINAGE- 10%				16,326.38	16,326.38
	40,525.30	42,082.31	27,078.36	16,326.38	163,263.84



Project: Awning Project  
 Subject: Construction Schedule (MCD Project Managers)

Items	Activity Description (MCD)	Duration (Days)	WK 1	WK 2	WK 3	WK 4	WK 5	WK 6	WK 7	WK 8	WK 9	WK 10	WK 11	WK 12	WK 13	WK 14	WK 15
1	Application for Building Permit	14															
2	Mobilization	3															
3	Demolition	11															
4	Disposal of demolished items (Phase 1)	7															
5	Disposal of demolished items (Phase 2)	7															
6	Rectification of Foundations/Footings	4															
7	Fabrication of Columns and Beams	17															
8	Installation of Columns	6															
9	Installation of Beams	6															
10	Installation of Channel Beams	6															
11	Installation of Suspended Cables	5															
12	Fascia butler and new purlins	7															
13	Installation of Gutter	11															
14	Installation Cirrugated roof sheet panels	11															
15	Installation of Down spall	5															
16	Electrical Works	11															
17	Re-installation of removed items	15															
18	Painting works	9															
19	Production and Submission of As-built plans	7															
20	Demobilization	10															

2022

# CONTRACTOR'S LICENSE

LOU LEON GUERRERO  
Governor of Guam

JOSH TENORIO  
Lt. Governor of Guam

Pursuant to the provisions of Chapter VII Title XI of the Government of Guam and the Rules and Regulations of the Contractors License Board, the Executive Director of Contractors hereby issues this license to:

**Luis E. Bustamante**  
dba: JJ Global Services

To engage in the business or act in the capacity of a contractor in the following classifications

**B,C13,C13A,C27,C33,C37,C42,C49,C55 & C68(Epoxy Coating/Injection, Generator Maintenance & Installation)**

This license is the property of the Executive Director of Contractors, not transferable, and shall be returned to the Executive Director upon demand when suspended, revoked, or invalidated for any reason. It becomes void if not renewed on or before the expiration date.

*Luis E. Bustamante*  
Signature of RME  
RME #

Signature of LICENSEE  
License # 7995

GRT # 96571

Certificate # C-0721-1173

Issued: July 13, 2021

Expires: June 30, 2022

*J. M. Casallo*  
JAMES M. CASALLO  
CLB BOARD CHAIRMAN



*Cecil "Buddy" L. Orsini*  
CECIL "BUDDY" L. ORSINI  
EXECUTIVE DIRECTOR



**Procurement Appeal No. OPA-PA-21-013**

# **Procurement Record**

## **Tab 12**

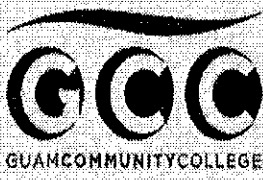

**GUAM COMMUNITY COLLEGE**  
 Bill/Ship TO MATERIALS MANAGEMENT SECTION  
 P. O. Box 23069 GMF  
 Barrigada, Guam 96921-3069  
 1 Sesame St. Mangilao, Guam 96913  
 Website: www.guamcc.edu  
 Email: materialsmanagement@guamcc.edu  
 Phone: 671.735.5540/2 Fax: 671.734.5238

Purchase Order Number:  
 P2101070

Issue Date: 07/27/21  
 Delivery Date: 07/27/21

Vendor:  
 B00145188  
 JJ Global Services  
 P.O. Box 217881 GMF  
 Barrigada GU 96921  
 Guam

Ship To:  
 Materials Management  
 PO Box 23069 GMF  
 Barrigada GU 96921

This Purchase Order Number must appear on all packages, shipping papers, correspondence, and invoices pertaining to the order. Please supply promptly the articles below or services. All invoices and statements must show the purchase order number to avoid delay in payment.  
 24 hour notice for large deliveries is recommended. Please call 671.735.5525 to make arrangements.  
 Billing Instructions: Send certified invoice with three (3) copies to Bill/Ship to address only.  
 Shipping Instructions: Make sure Bill/Ship to address appears on the crate or package. Invoice must accompany shipment.

ITEM	DESCRIPTION	QUANTITY	UOM	UNIT PRICE	EXTENDED AMOUNT
1	2015 Contractual Services Bid No. GCC-FB-21-009 Replacement of Building 900 Metal Awning Structure. Description of work and cost break down: a, b, c with Option 2 Galvanized, d, e, f, g, h, 1) Total Cost \$163,263.84. Timeline to complete project within ninety (90) consecutive calendar days upon receipt of purchase order and inclusive of the building permit process and material lead-time. *****FOR INTERNAL USE ONLY*****  <i>Emma Reus</i> <i>8-4-21</i> 		EA		163,263.84

REMARKS:

TOTAL AUTHORIZED ►

CONTINUED

FOR GUAM COMMUNITY COLLEGE USE ONLY

*Joleen M. Evangelista*

Joleen M. Evangelista  
 Procurement & Inventory Administrator

*R. Magana*

Rodalyn Gerardo, CIA, CGFM, CPA, CGAP, CGMA, CICA  
 Vice President, Finance & Administration  
 Certifying Officer

*Mary A. Y. Ojeda*

Mary A. Y. Ojeda, Ed.D.  
 President

JUL 28 2021

Date

MATERIALS MANAGEMENT



**GUAM COMMUNITY COLLEGE**  
 Bill/ship TO MATERIALS MANAGEMENT SECTION  
 P. O. Box 23069 GMF  
 Barrigada, Guam 96921-3069  
 1 Sesame St, Mangilao, Guam 96913  
 Website: www.guamcc.edu  
 Email: materialsmanagement@guamcc.edu  
 Phone: 671.735.5540/2 Fax: 671.734.5238

Purchase Order Number

P2101070

Issue Date: 07/27/21

Delivery Date: 07/27/21

This Purchase Order Number must appear on all packages, shipping papers, correspondence, and invoices pertaining to the order. Please supply promptly the articles below or services. All invoices and statements must show the purchase order number to avoid delay in payment.

24 hour notice for large deliveries is recommended. Please call 671.735.5625 to make arrangements.

Billing Instructions: Send certified invoice with three (3) copies to Bill/Ship to address only.

Shipping Instructions: Make sure Bill/Ship to address appears on the crate or package, invoices must accompany shipment.

Vendor:

B00145188  
 JJ Global Services  
 P.O. Box 217881 GMF  
 Barrigada GU 96921  
 Guam

Ship To:

Materials Management  
 PO Box 23069 GMF  
 Barrigada GU 96921

ITEM	DESCRIPTION	QUANTITY	UOM	UNIT PRICE	EXTENDED AMOUNT
	Requestor: Francisco Palacios (P&D) FOAP: 30.1065.7230.66.P2106 (Contractual Services) Requisition: R2101180				

REMARKS:

DISCOUNT: .00  
 ADDL CHARGES: .00  
 TOTAL TAXES: .00

TOTAL AUTHORIZED ► 163,263.84

FOR GUAM COMMUNITY COLLEGE USE ONLY

*Joleen M. Evangelista*

Joleen M. Evangelista  
 Procurement & Inventory Administrator

*R. Magana*

Rodalyn Gerardo, CIA, CGFM, CPA, CGAP, CGMA, CICA  
 Vice President, Finance & Administration  
 Certifying Officer

*Mary A. Y. Okada*

Mary A. Y. Okada, Ed.D.  
 President

JUL 28 2021

Date

MATERIALS MANAGEMENT

GCC PR0395

**CONTRACT NO. P2101070**

**CONTRACT  
(Replacement of Building 900 Metal Awning Structure)**

**JJ Global Services  
(Contractor)**

**Guam Community College  
(GCC)**

**Bid No: GCC-FB-21-009**

**Amount: \$163,263.84**

**Place: Guam Community College**

**FORMAL CONTRACT**

**THIS AGREEMENT AND FORMAL CONTRACT, made and entered into this 27th day of July 2021, by and between Guam Community College, hereinafter called "GCC", represented by the Contracting officer executing this contract, party of the first part, and JJ Global Services, a corporation of the Territory of Guam, hereinafter called the "Contractor" party of the second part.**

**WITNESSETH, That whereas the Guam Community College intends to Replace the Metal Awning Structure at Building 900 with galvanized iron (option 2) called the "Project", in accordance with the scope of work and other contract documents.**

**NOW THEREFORE, Guam Community College and Contractor for the considerations hereinafter set forth, agree as follows:**

**I. THE CONTRACTOR AGREES** to construct and furnish all the necessary labor, materials, equipment, tools and services necessary to perform and complete in a safe and efficient manner all the work required for the performance of the Project, in strict compliance with the contract documents herein mentioned, which are hereby made a part of the contract.

**(a) Contract Time:** The contractor agrees to commence work under this contract upon written notice to proceed which is established as July 27, 2021, and to complete the project ready for use and operation based on the below requirements:

**90 Calendar Days upon Notice to Proceed Date  
Completion Date: October 24, 2021**

**II. Guam Community College agrees to pay, subject to availability of funds, and the Contractor agrees to accept, in full payment for the performance of this contract, a total contract amount of \$163,263.84 using Galvanized Iron.**

**III. CONTRACT DOCUMENTS:** It is hereby mutually agreed that the following list of specifications and documents which are attached hereto, bound herewith or incorporated herein by reference shall constitute the contract documents, all of which are part hereof, and collectively evidence and constitute the contract between the parties hereto, and they are as fully a part of this Agreement as if they were set out verbatim and in full herein, and are designated as follows:

- (a) Instructions to Bidders**
- (b) Bid Form**
- (c) Bid Schedule**
- (d) Bid Bond**
- (e) Subcontractor: None**
- (f) Performance Bond**
- (g) General Provisions**

- (h) General Conditions
- (i) Special Provisions
- (j) SOW
- (k) Amendments

- IV. **LIQUIDATED DAMAGES:** The Contractor further agrees to pay to GCC the sum of one-fourth of one percent (1%) of the contract amount per calendar day not as a penalty, but as reasonable liquidated damages for breach of this contract by the Contractor by his failing, neglecting or refusing to complete work within the time herein specified and said sums shall be paid for each consecutive calendar day thereafter that the Contractor shall be in default after the time stipulated in the contract for completing the work ready for use and/or operation. Liquidated damages will start after contract completion deadline.
- V. **SPECIAL PERMITS AND LICENSES:** The Contractor shall, at his own expense, procure all permits, certificates, and licenses and shall give notices and necessary reports required by law for the Scope of Work. Failure to maintain required permits and licenses shall be grounds for immediate termination of contract.
- VI. **CONTROL:** The GCC President or the Assistant Director, Planning & Development/Facilities will meet periodically with the Contractor for the purpose of reviewing progress and providing necessary guidance to the Contractor in solving problems.
- VII. **JUSTIFICATION OF DELAY:** The Contractor guarantees that the project will be completed within the agreed upon completion date. If however, the Contractor cannot comply with the completion requirement, it is the Contractor's responsibility to advise GCC in writing explaining the cause and reasons for delay.
- VIII. **GENERAL COMPLIANCE WITH LAWS:** In the performance of work provided herein, Contractor agrees that it shall be conducted in full compliance with any and all applicable laws, rules and regulation adopted or promulgated by any governmental agency or regulatory body, both territorial and federal. Contractor assumes full responsibility for the payment of all contributions payroll taxes or assessments, territorial or federal, and further agrees to meet all requirements that may be specified under regulations of administrative officials or bodies charged with enforcement of any territorial or federal laws.



- IX. EQUAL EMPLOYMENT OPPORTUNITY:** Section 3.01 OF THE Executive Order 10935 dated march 7, 1965 requires the Contractor not to discriminate against any employee or applicant for employment because of race, creed, color or national origin. The Contractor will take affirmative action to ensure that employees are treated equally during employment without regards to their race, creed, color or national origin.
- X. CONVENANT AGAINST CONTINGENT FEES.** The Contractor warrants that he has not employed any person to solicit or secure the contract upon any agreement for a commission, percentage, brokerage or contingent fee. Breach of this warranty shall give GCC the right to terminate the contract, or in its discretion, to deduct from the contract price or consideration the amount of such commission, percentage, brokerage or contingent fee. The warranty shall not apply to commissions payable by contractors upon contracts or sales secured or made through bonafide established commercial or selling agencies maintained by the Contractor for the purpose of securing business.
- XI. OTHER CONTRACTS.** GCC may award other contracts for additional work, and the Contractor shall fully cooperate with such other contractors and carefully fit his own work to that provided under other contracts as may be directed by the Contracting Officer. The Contractor shall not commit or permit any act which will interfere with the performance of work by any other contractor.
- XII. DISPUTES.** Except as otherwise specifically provided in this contract, all disputes concerning questions of fact arising under this contract shall be decided by the President of Guam Community College whose decision shall be final and conclusive upon the parties thereto. In the meantime the Contractor shall diligently proceed with the work as directed.
- XIII. CONTRACT BINDING.** It is agreed that this contract and all the Covenants hereof shall inure to the benefit of and be binding upon GCC and the Contractor respectively and his partners, successors, assignees and legal representatives. Neither GCC nor the Contractor shall have the right to assign, transfer or sublet his interest or obligations hereunder without written consent of the other party. It is hereby mutually agreed by and between the parties hereto that no mechanic, contractor, subcontractor, material man or other person can or will contract for or in any other manner have or acquire any lien upon the building or works covered by this contract, or the land upon which the same is situated.

- XIV. INDEMNITY.** Contractor agrees to save and hold harmless GCC, its officers, agents, representatives, successors and assigns and other governmental agencies from any and all suits or actions of every nature and kind, which may be brought for or on account of any injury, death, or damage arising or growing out of the acts or omissions of the Contractor, Contractor's officers, agents, servants or employees under this contract.
- XV. MODIFICATION OR AMENDMENTS:** No modification, amendment, alteration or change of the terms and conditions of this Agreement shall be valid or enforceable unless made in writing and executed by both parties hereto and approved by appropriate action by GCC.
- XVI. ATTORNEY FEES:** If either GCC or Contractor institute legal action to enforce the provisions of this Agreement, the prevailing party shall be entitled to recover reasonable attorney's fees and cost of suit.
- XVII. INSURANCE:** During the term of this agreement, Contractor must maintain insurance as required on the Notice of Intent to Award. Contractor is responsible for obtaining all applicable insurance. GCC assumes no liability for any accident or injury that may occur to the Contractor, his agents, dependents, or personal property while on GCC premises performing said scope of service.
- XVIII. ASSIGNMENT OF AGREEMENT:** Assignment will not be accepted without approval from GCC. Request for approval of assignment must be made with submission of proposal. No assignment will be accepted if request is not made in writing with the proposal.
- XIX. RESTRICTIONS AGAINST CONTRACTORS EMPLOYING CONVICTED SEX OFFENDERS:** The contractor warrants that no person in its employments who has been convicted of a sex offense under the provisions of Chapter 25 of Title 9 of the Guam Code Annotated, or who has been convicted of an offense with the same elements as heretofore defined in any other jurisdiction, or who is listed on the Sex Offender Registry shall provide services on behalf of the contractor while on government property, with the exception of public highways. If any employee of contractor is providing services on government property and is convicted subsequent to an award of a contract, then the contractor warrants that it will notify GCC of the conviction within twenty-four hours of the conviction, and will remove immediately such convicted person from providing services on government property. If the contractor is found to be in violation of any of the provisions of this paragraph, then GCC will give notice to the contractor to take corrective action. The contractor shall take corrective action within twenty-four hours of notice from GCC, and the contractor shall notify GCC when action has been taken. If the contractor fails to take corrective steps within twenty-four hours of notice from GCC, then GCC in its sole discretion may

suspend temporarily any contract for services until corrective action has been taken.

**XX. NOTICES:** All notices, requests, demands and other communications which are required or permitted to be given under this Agreement shall be made in writing and shall be deemed to have been duly given upon the delivery or receipt thereof, as the case may be, if delivered personally, or shall be deemed to be received as of the date of mailing if sent by registered or certified mail, return receipt requested, postage prepaid as follows:

GCC: Guam Community College  
P.O. Box 23069  
GMF, Guam 96921

The Contractor: JJ Global Services  
P.O. Box 217881 GMF  
Barrigada, Guam 96921

**IN THIS WHEREOF parties hereto have executed this contract as of the day and year first written.**

\_\_\_\_\_  
Luis E. Bustamante  
CEO  
JJ Global Services

*Mary A. Y. Okada on 06/20/21*  
\_\_\_\_\_  
Mary A. Y. Okada, Ed.D. Reg  
President  
Guam Community College

**CERTIFIED FUNDS AVAILABE**

Contract No.: P2101070  
FOAP: 30.1065.7230.66.P2106 pml 7/26/2021  
Contract Amount: \$163,263.84

**Procurement Appeal No. OPA-PA-21-013**

# **Procurement Record**

## **Tab 13**

**Joleen Evangelista**

---

**From:** gccpresident@guamcc.edu  
**Sent:** Tuesday, October 12, 2021 5:55 PM  
**To:** luis.bustamante34@gmail.com; aileen@jjglobal.services  
**Cc:** joleen.evangelista@guamcc.edu; 'Rodalyn Gerardo'  
**Subject:** P2101070 GCC-FB-21-009, Replacement of Building 900 Metal Awning Structure  
**Attachments:** Letter to JJ Global Oct 2021.pdf

Mr. Bustamante and Ms. De Dios,

Please see the attached response to JJ Global's letter dated October 5, 2021.

Please note that an attempt to hand deliver the letter was made this afternoon by Ms. Shirley August however, the letter was rejected by the front office personnel. At 4:20 pm, Ms. August received a call advising that the letter can be dropped off since you and Ms. De Dios were back in the office. Per the discussion with Ms. De Dios, GCC will re-deliver the original letter tomorrow.

Please acknowledge receipt of this letter ASAP or by 12Noon October 13, 2021.

*Esther Muna*

Private Secretary to the President  
Guam Community College  
P.O. Box 23069  
Barrigada, Guam 96921  
Tel: (671) 735-5700  
[www.guamcc.edu](http://www.guamcc.edu)



*E-mail administered by Guam Community College*



OFFICE OF THE PRESIDENT

OCT 12 2021

Luis E. Bustamante  
President/CEO  
JJ Global Services  
215 Rojas Street, Suite 126 Harmon Industrial Park  
Tamuning, Guam 96913  
P.O. Box 217881  
Barrigada, Guam 96921

Via Email to [luis.bustamante34@gmail.com](mailto:luis.bustamante34@gmail.com)  
and [aileen@jjglobal.services](mailto:aileen@jjglobal.services)

Subject: Letter received October 5, 2021  
Project: GCC-FB-21-009, Replacement of Building 900 Metal Awning Structure

Dear Mr. Bustamante,

GCC received your letter dated October 5, 2021 stating that JJ Global is protesting the termination of its contract formed "pursuant to the terms of the IFB." Having considered in detail the issues presented thereby, GCC denies JJ Global's protest.

At the outset, termination of a contract is not valid grounds for a protest under Guam's procurement laws. See 5 GCS § 5425(a); 2 GARR § 9101(c). Contract disputes are resolved through a different procedure. See 5 GCA § 5427.

Moreover, even assuming for the sake of argument that JJ Global could protest termination of its contract, this protest would not be timely submitted under Guam's procurement laws. A protest must be submitted "within 14 (fourteen) days after [the protestor] knows or should know of the facts giving rise [to the protest]." 5 GCA § 5425(a). JJ Global's protest argues that it did not need to comply with GCC's request to sign the written contract for a contract to exist. GCC first requested that JJ Global sign the written contract on July 27, 2021. After several delays instigated by JJ Global, GCC finally required that JJ Global return the signed contract by August 31, 2021. These facts are the basis of this protest and arose, respectively, 70 and 35 days before JJ Global submitted it on October 5, 2021. Therefore, even if valid, this protest is untimely because JJ Global clearly knew of the facts giving rise to this protest much longer than 14 days before submitting it to GCC. See *DFS Guam L.P. v. GLAA*, 2020 Guam 20 ¶¶ 84-89, *Pacific Data Systems, Inc. v. GHURA*, OPA-PA-21-001.

Accordingly, GCC denies this protest and remains firm in its decision to cancel Purchase Order No. P2101070.

GUAMCOMMUNITYCOLLEGE  
Email: [gccpresident@guamcc.edu](mailto:gccpresident@guamcc.edu) | Phone: (671) 753-5700 | [www.guamcc.edu](http://www.guamcc.edu)  
Location: 1 Sesame Street, Mangilao, Guam

GCC PR0403

You have the right to administrative and judicial review of this decision and an appeal must be filed within fifteen (15) days after your receipt of this decision.

Please acknowledge receipt of this letter via a response email to [joleen.evangelista@guamcc.edu](mailto:joleen.evangelista@guamcc.edu) and [materialsmanagement@guamcc.edu](mailto:materialsmanagement@guamcc.edu) ASAP or no later than October 13, 2021.

Si Yu'os Ma'ase,

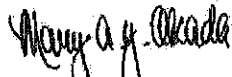

Mary A.Y. Okada, Ed.D.  
President

cc: Joleen Evangelista



OFFICE OF THE PRESIDENT

OCT 12 2021

Luis E. Bustamante  
President/CEO  
JJ Global Services  
215 Rojas Street, Suite 126 Harmon Industrial Park  
Tamuning, Guam 96913  
P.O. Box 217881  
Barrigada, Guam 96921

ACKNOWLEDGMENT  
COPY

Via Email to [luis.bustamante34@gmail.com](mailto:luis.bustamante34@gmail.com)  
and [aileen@jjglobal.services](mailto:aileen@jjglobal.services)

Subject: Letter received October 5, 2021  
Project: GCC-FB-21-009, Replacement of Building 900 Metal Awning Structure

Aileen de Dios  
10/17/21  
Luis

Dear Mr. Bustamante,

GCC received your letter dated October 5, 2021 stating that JJ Global is protesting the termination of its contract formed "pursuant to the terms of the IFB." Having considered in detail the issues presented thereby, GCC denies JJ Global's protest.

At the outset, termination of a contract is not valid grounds for a protest under Guam's procurement laws. See 5 GCS § 5425(a); 2 GARR § 9101(c). Contract disputes are resolved through a different procedure. See 5 GCA § 5427.

Moreover, even assuming for the sake of argument that JJ Global could protest termination of its contract, this protest would not be timely submitted under Guam's procurement laws. A protest must be submitted "within 14 (fourteen) days after [the protestor] knows or should know of the facts giving rise [to the protest]." 5 GCA § 5425(a). JJ Global's protest argues that it did not need to comply with GCC's request to sign the written contract for a contract to exist. GCC first requested that JJ Global sign the written contract on July 27, 2021. After several delays instigated by JJ Global, GCC finally required that JJ Global return the signed contract by August 31, 2021. These facts are the basis of this protest and arose, respectively, 70 and 35 days before JJ Global submitted it on October 5, 2021. Therefore, even if valid, this protest is untimely because JJ Global clearly knew of the facts giving rise to this protest much longer than 14 days before submitting it to GCC. See *DFS Guam L.P. v. GIAA*, 2020 Guam 20 ¶¶ 84-89, *Pacific Data Systems, Inc. v. GHURA*, OPA-PA-21-001.

Accordingly, GCC denies this protest and remains firm in its decision to cancel Purchase Order No. P2101070.

GUAMCOMMUNITYCOLLEGE

Email: [gccpresident@guamcc.edu](mailto:gccpresident@guamcc.edu) | Phone: (671) 753-5700

GCC PR0405



**Joleen Evangelista**

---

**From:** Aileen de Dios <aileen@jjglobal.services>  
**Sent:** Tuesday, October 5, 2021 9:51 AM  
**To:** Joleen Evangelista  
**Cc:** Luis E. Bustamante; Klt Casin; Virginia Tedpahogo; Julie Ulloa-Heath; Admin Assistant; Francisco 'Kiko' Palacios; Rodalyn Gerardo; Ambros Mori Rokop Jr.  
**Subject:** Re: GCC-FB-21-009 Replacement of Bldg. 900 Metal Awning Structure  
**Attachments:** GCC-FB-21-009 REPLACEMENT OF AWNING STRUCTURE - LETTER OF PROTEST .pdf

Hi Ms. Joleen,

Kindly refer to our formal response pursuant to your email below.  
Thank you.

*All the best,*

**Aileen de Dios**  
General Manager  
<http://www.jjglobal.services/>  
E: [aileen@jjglobal.services](mailto:aileen@jjglobal.services)  
O: 671-632-1179  
F: 671-632-3550

On Wed, Sep 22, 2021 at 4:37 PM Aileen de Dios <aileen@jjglobal.services> wrote:  
Hafa Adai Ms. Joleen,

Confirming receipt of your email and our formal response forthcoming.  
Thank you.

*All the best,*

**Aileen de Dios**  
General Manager  
<http://www.jjglobal.services/>  
E: [aileen@jjglobal.services](mailto:aileen@jjglobal.services)  
O: 671-632-1179  
F: 671-632-3550

On Wed, Sep 22, 2021 at 12:27 PM Joleen Evangelista <[joleen.evangelista@guamcc.edu](mailto:joleen.evangelista@guamcc.edu)> wrote:

Ms. De Dios and Mr. Bustamante,

**Please note:** Correction to the date of when the email was sent: The date is 8/30/21 and not 9/30/21.

Please acknowledge receipt of this email ASAP or by 5:00 p.m., September 22, 2021.

Thank you and Best Regards,

Joleen M. Evangelista

Procurement & Inventory Administrator

---

**From:** Joleen Evangelista [mailto:joleen.evangelista@guamcc.edu]  
**Sent:** Tuesday, September 21, 2021 5:21 PM  
**To:** 'Aileen de Dios' <aileen@jjglobal.services>; 'Luis Bustamante' <luis.bustamante@jjglobal.services>  
**Cc:** 'Kit Casin' <kit.casin@jjglobal.services>; 'Virginia Tedpahogo' <virginia@jjglobal.services>; 'Julie Ulloa-Heath' <julie.ulloaheath@guamcc.edu>; 'Admin Assistant' <admin@jjglobal.services>; 'Francisco 'Kiko' Palacios' <francisco.palacios1@guamcc.edu>; 'Rodalyn Gerardo' <rodalyn.gerardo@guamcc.edu>; 'Luis E. Bustamante' <luis.bustamante34@gmail.com>  
**Subject:** RE: GCC-FB-21-009 Replacement of Bldg. 900 Metal Awning Structure

Ms. De Dios and Mr. Bustamante,

Please advised that since JJ Global has not submitted the signed contract, the purchase order is canceled. Please note the email sent on 9/30/21 requesting for the signed contract to be submitted by August 31, 2021.

Please let me know if you have any questions.

Best Regards,

Joleen M. Evangelista

Procurement & Inventory Administrator

---

**From:** Joleen Evangelista [<mailto:joleen.evangelista@guamcc.edu>]  
**Sent:** Monday, August 30, 2021 4:54 PM  
**To:** 'Aileen de Dios' <[aileen@jiglobal.services](mailto:aileen@jiglobal.services)>; 'Luis Bustamante' <[luis.bustamante@jiglobal.services](mailto:luis.bustamante@jiglobal.services)>  
**Cc:** 'Kit Casin' <[kit.casin@jiglobal.services](mailto:kit.casin@jiglobal.services)>; 'Virginia Tedpahogo' <[virginia@jiglobal.services](mailto:virginia@jiglobal.services)>; 'Julie Ulloa-Heath' <[julie.ulloaheath@guamcc.edu](mailto:julie.ulloaheath@guamcc.edu)>; 'Admin Assistant' <[admin@jiglobal.services](mailto:admin@jiglobal.services)>; 'Francisco 'Kiko' Palacios' <[francisco.palacios1@guamcc.edu](mailto:francisco.palacios1@guamcc.edu)>; 'Rodaly Gerardo' <[rodalyn.gerardo@guamcc.edu](mailto:rodalyn.gerardo@guamcc.edu)>; 'Luis E. Bustamante' <[luis.bustamante34@gmail.com](mailto:luis.bustamante34@gmail.com)>  
**Subject:** GCC-FB-21-009 Replacement of Bldg. 900 Metal Awning Structure

Ms. De dios and Mr. Bustamante,

GCC is in receipt of your letter dated August 26, 2021. Please be advised that the executed contract must be received by our office by 5:00pm, CHST on August 31, 2021. The request to add additional language is not approved.

Please note, we have not received the drawings for approval.

Thank you.

Joleen M. Evangelista

Procurement & Inventory Administrator

---

**From:** Aileen de Dios [<mailto:aileen@jiglobal.services>]  
**Sent:** Thursday, August 26, 2021 10:05 PM  
**To:** Joleen Evangelista <[joleen.evangelista@guamcc.edu](mailto:joleen.evangelista@guamcc.edu)>  
**Cc:** Kit Casin <[kit.casin@jiglobal.services](mailto:kit.casin@jiglobal.services)>; Virginia Tedpahogo <[virginia@jiglobal.services](mailto:virginia@jiglobal.services)>; Julie Ulloa-Heath <[julie.ulloaheath@guamcc.edu](mailto:julie.ulloaheath@guamcc.edu)>; Admin Assistant <[admin@jiglobal.services](mailto:admin@jiglobal.services)>; Francisco 'Kiko' Palacios <[francisco.palacios1@guamcc.edu](mailto:francisco.palacios1@guamcc.edu)>; Rodaly Gerardo <[rodalyn.gerardo@guamcc.edu](mailto:rodalyn.gerardo@guamcc.edu)>; Luis E. Bustamante <[luis.bustamante34@gmail.com](mailto:luis.bustamante34@gmail.com)>  
**Subject:** Re: Replacement of Bldg. 900 Metal Awning Structure

Hafa Adai Ms Joleen,

Pls see attached letter pursuant to the signing of the contract.

*All the best,*

**Aileen de Dios**

*General Manager*

<http://www.jjglobal.services/>

E: [aileen@jjglobal.services](mailto:aileen@jjglobal.services)

O: 671-632-1179

F: 671-632-3550

On Wed, Aug 25, 2021 at 2:01 PM Joleen Evangelista <[joleen.evangelista@guamcc.edu](mailto:joleen.evangelista@guamcc.edu)> wrote:

Dear Mr. Bustamante and the JJ Global Services Team:

I would like to follow up on the following for the items for the above project:

1. GCC needs the signed original contract by Mr. Luis Bustamante. On August 9, 2021, GCC was informed that he was off-island and that the signed contract would be submitted however, as of 8/25/2021 GCC has not received the signed contract. GCC Materials management Office has called to follow up by phone and in person however, it is Ms. Casin did not know status of the signed contract. The PO was acknowledged and received by JJ Global since 8/4/2021. Please note that Mr. Bustamante attended an on-site (informal post award) meeting on August 11, 2021 with additional JJ Global employees however, the signed contract was not submitted.
2. Please confirm if the drawings/plans for the project have been submitted to GCC Facilities Office (Dr. Julie Ulloa-Heath and Mr. Kiko Palacios). There was a request for additional time to submit the drawings to GCC for approval so that JJ Global can obtain the permit to start the

project. Please confirm if the drawings are ready for submission to GCC since the additional 15 days to submit the drawings has passed.

3. Is JJ Global able to proceed with this project and carry out all the required work to complete as stated in the bid? Please advise.

Please provide a response to this request ASAP or by Thursday, August 26, 2021 via email to: [materialsmanagement@guamcc.edu](mailto:materialsmanagement@guamcc.edu)  
<<mailto:materialsmanagement@guamcc.edu>> .

Thank you and Regards,

Joleen M. Evangelista

Procurement & Inventory Administrator

From: Joleen Evangelista [<mailto:joleen.evangelista@guamcc.edu>]  
Sent: Wednesday, August 4, 2021 4:17 PM  
To: 'Kit Casin' <[kit.casin@jjglobal.services](mailto:kit.casin@jjglobal.services)>  
Cc: 'Julie Ulloa-Heath' <[julie.ulloaheath@guamcc.edu](mailto:julie.ulloaheath@guamcc.edu)>; 'Aileen de Dios' <[aileen@jjglobal.services](mailto:aileen@jjglobal.services)>; 'Luis E. Bustamante' <[luis.bustamante34@gmail.com](mailto:luis.bustamante34@gmail.com)>; 'Virginia Tedpahogo' <[virginia@jjglobal.services](mailto:virginia@jjglobal.services)>; 'Florenda Miranda' <[flor@jjglobal.services](mailto:flor@jjglobal.services)>; 'Admin Assistant' <[admin@jjglobal.services](mailto:admin@jjglobal.services)>  
Subject: RE: Replacement of Bldg. 900 Metal Awning Structure

Kit,

Please see page 3 of 7 in the SOW titled: Bid Description Replacement of Building 900 Metal Awning Structure GCC Bid No: GCC-FB-21-009.

Please acknowledge receipt of this email.

Should you need further assistance, please do not hesitate to contact us.

Thank you

Best Regards,

Kit Casin

Executive Secretary

Services

PO Box 217881

GMF Barrigada GU 96921

Tel # 671-633-2603

email: kit.casin <<mailto:kit.casin@jjglobal.services>> @jjglobal.services

<<http://www.jjglobal.services/>> <http://www.jjglobal.services/>

--

E-mail administered by Guam Community College



*E-mail administered by Guam Community College*



October 5, 2021

To: Guam Community College  
PO Box 23069, GMF, Guam 96921  
Attn: Joleen Evangelista (Procurement & Inventory Administrator)

Re: GCC-FB-21-009 Protest Letter  
Replacement of Building 900 Metal Awning Structure

Dear Ms. Evangelista,

JJ Global protests GCC's September 22, 2021 cancellation of the award and purchase order for IFB No. GCC-FB-21-009. JJ Global's signature of the proposed contract referenced in your email is not grounds to cancel or terminate the award. Paragraph 29 of the Instructions of the GCC-FB-21-009 states in pertinent part:

"Award shall be made to the lowest responsible and responsive bidder, whose bid is determined to be the most advantageous to the Government, taking into consideration the evaluation factors set forth in this solicitation. No other factors or criteria shall be used in the evaluation. Award issued to the lowest responsible bidder within the specified time for acceptance as indicated in the solicitation, result in a binding contract without further action by either party. The right is reserved as the interest of the Government and may require to waive any minor irregularity in the bid received pursuant to 2 GAR, Div. 4 §3109(m)(4)(B)."

Therefore, pursuant to the terms of the IFB, the July 27, 2021 award to JJ Global resulted in a binding contract without further action by either GCC or JJ Global. Moreover, GCC may not terminate the contract entered with JJ Global in violation of the terms of the IFB.

Based on the foregoing, JJ Global respectfully requests that its protest be granted, GCC rescind their cancellation of the award to JJ Global, and for any other relief available to JJ Global under Guam law.

Very respectfully,

Luis E. Bustamante  
President/CEO  
JJ Global Services

Physical Address: 215 Rojas Street, Suite 126 Harmon Industrial Park, Tamuning Guam, 96913  
Mailing Address: PO Box 217881, GMF Barrigada Guam 96921  
Tel: (671) 632-1179 Fax: (671) 632-3550  
Email: jjg@teleguam.net

GCC PR0413



10/12/21  
called 2:48pm  
Fran; as per Fran  
Mr. Bustamante  
and Ms. de Dios.  
not in the  
office.  
10/28/21  
spoke to Ms. de Dios

October 5, 2021

To: Guam Community College  
PO Box 23069, GMF, Guam 96921  
Attn: Joleen Evangelista (Procurement & Inventory Administrator)

Re: GCC-FB-21-009 Protest Letter  
Replacement of Building 900 Metal Awning Structure

Dear Ms. Evangelista,

JJ Global protests GCC's September 22, 2021 cancellation of the award and purchase order for IFB No. GCC-FB-21-009. JJ Global's signature of the proposed contract referenced in your email is not grounds to cancel or terminate the award. Paragraph 29 of the Instructions of the GCC-FB-21-009 states in pertinent part:

"Award shall be made to the lowest responsible and responsive bidder, whose bid is determined to be the most advantageous to the Government, taking into consideration the evaluation factors set forth in this solicitation. No other factors or criteria shall be used in the evaluation. Award issued to the lowest responsible bidder within the specified time for acceptance as indicated in the solicitation, result in a binding contract without further action by either party. The right is reserved as the interest of the Government and may require to waive any minor irregularity in the bid received pursuant to 2 GAR, Div. 4 §3109(m)(4)(B)."

Therefore, pursuant to the terms of the IFB, the July 27, 2021 award to JJ Global resulted in a binding contract without further action by either GCC or JJ Global. Moreover, GCC may not terminate the contract entered with JJ Global in violation of the terms of the IFB.

Based on the foregoing, JJ Global respectfully requests that its protest be granted, GCC rescind their cancellation of the award to JJ Global, and for any other relief available to JJ Global under Guam law.

Very respectfully,

Luis E. Bustamante  
President/CEO  
JJ Global Services

Physical Address: 215 Rojas Street, Suite 126 Harmon Industrial Park, Tamuning Guam, 96913  
Mailing Address: PO Box 217881, GMF Barrigada Guam 96921  
Tel: (671) 632-1179 Fax: (671) 632-3550  
Email: jjg@teleguam.net