



Jerrick Hernandez <jhernandez@guamopa.com>

FW: GSA-055-19 Hearing

Erik Soderholm <erik@soderholmbus.com>

Tue, Sep 15, 2020 at 1:46 PM

To: Jerrick Hernandez <jhernandez@guamopa.com>

Cc: "Matthew E. Wolff" <mwoff@oagguam.org>, charles@mcdonald.law, Denise Soderholm <denise@soderholmbus.com>, Gus Soderholm <gus@soderholmbus.com>, Claudia Acfalle <Claudia.Acfalle@gsadoa.guam.gov>, Robert Kono <robert.kono@gsa.guam.gov>, Anita Cruz <Anita.Cruz@gsadoa.guam.gov>, Christine Tedtaotao <Christine.Tedtaotao@gsadoa.guam.gov>, Celestin Babauta <celestin.babauta@grta.guam.gov>, "Rally M. Pilipina" <rally.pilipina@grta.guam.gov>

Jerrick: Per your request, please find our List of Witnesses and Exhibit's A – O for your review. We are emailing our List of Issues separately.

R. Erik Soderholm

Vice President

Soderholm Sales & Leasing, Inc.

2044 Dillingham Blvd. Honolulu, HI 96819

Mailing address: P.O. Box 19010 Honolulu, HI 96817

808-834-1417 Fax 808-834-1070

erik@soderholmbus.com www.soderholmbus.com

This message **and any attachments** contain confidential information **and is the property of Soderholm Sales and Leasing, Inc. and/or Soderholm Mobility, Inc.** If you are not the intended recipient (or authorized to receive for the recipient) and received this message in error; any use, distribution or disclosure is strictly prohibited. Please contact the sender by reply e-mail and delete all copies of this message from your computer system.

From: Jessica Scheuring [mailto:jessica@soderholmbus.com]**Sent:** Monday, September 14, 2020 5:04 PM**To:** Erik Soderholm <erik@soderholmbus.com>**Subject:** GSA-055-19 Hearing

Erik,

See attached.

Thanks,

Jessica Scheuring

Administrative Assistant

Soderholm Bus & Mobility

PO Box 19010 (Mailing)

Honolulu, HI 96817

2044 Dillingham Blvd. (Shipping)

Honolulu, HI 96819

808-834-1417 (ofc)

808-834-1070 (fax)

www.soderholmbus.com

This message **and any attachments** contain confidential information **and is the property of Soderholm Sales and Leasing, Inc. and/or Soderholm Mobility, Inc.** If you are not the intended recipient (or authorized to receive for the recipient) and received this message in error; any use, distribution or disclosure is strictly prohibited. Please contact the sender by reply e-mail and delete all copies of this message from your computer system.

16 attachments **List of Witnesses.pdf**
171K **Exhibit A.pdf**
56K **Exhibit B.pdf**
324K **Exhibit C.pdf**
57K **Exhibit D.pdf**
64K **Exhibit E.pdf**
309K **Exhibit F.pdf**
30K **Exhibit G.pdf**
1002K **Exhibit H.pdf**
271K **Exhibit I.pdf**
287K **Exhibit J.pdf**
172K **Exhibit K.pdf**

179K

 **Exhibit L.pdf**
183K

 **Exhibit M.pdf**
102K

 **Exhibit N.pdf**
318K

 **Exhibit O.pdf**
8708K

EXHIBIT A

Number of Bidders <u>2</u> Number of Bids Received <u>2</u> Number of IFB Amendments <u>4</u>		Department of Administration 590 S. Marine Corps Drive, Suite 219 Tamuning, Guam 96913 Government of Guam ABSTRACT OF IFB										IFB Number: GSA-055-19 Opening Date: 11-15-19 Time: 2:00 PM					
DESCRIPTION																	
14 PASSENGER, ADA COMPLIANT GRTA BUSES																	
OFFEROR(S)		Acceptance Time	Delivery Acceptance	Delivery Specified IN IFB (30 Days)	A	B	C	D	E	F	G	H	I	Item No.	Qty.	Unit	
<i>SODER HOLM BUSES & LIABILITY</i> <i>BID GUARANTEE # N/A OHIO CASUALTY INS. CO. 15% TBA 10/20/19</i> <i>PAA, BROCHURES, submitted.</i>		2:29 PM 11/14/19			X	X	X	X	X	X	X	X	X	BID FORM			
														10 ea	\$158,700.00		
														MANE/EL DORADO / 2020			
														MR/MD ADVANTAGE 1240			
														DOD 240 Calendar Days			
														BID FORM			
<i>MONSTER AUTO SPOT</i> <i>SBLC 1/13/2019 BOG CR# 01-SB-1586 # 268,500.00</i> <i>ROCHURE submitted.</i>		1:53 PM 11/15/19			X	X	X	X	X	X	X	X	X	10 ea	\$163,74.20		
														MANE/PR General Interest / 2020			
														MR/MD GMC / Savana 4500 (Contracting w/ Best Craft Bus Conversion)			
														DOD 240 Calendar Days			
personal supervision and that the same as of all bidders have been entered hereon														LEGEND(S)			
(A) Affidavit re Ethical Standards														(A) Affidavit re Ethical Standards			
(B) Affidavit re No Gratuities or Kickbacks														(B) Affidavit re No Gratuities or Kickbacks			
(C) Restriction Against Sexual Offenders Affidavit														(C) Restriction Against Sexual Offenders Affidavit			
(D) Form E, Declaration Re Compliance with U.S. DOL Wage Determination														(D) Form E, Declaration Re Compliance with U.S. DOL Wage Determination			
(E) Affidavit re Non-Collusion														(E) Affidavit re Non-Collusion			
(F) Affidavit Disclosing Ownership and Commission														(F) Affidavit Disclosing Ownership and Commission			
(G) Affidavit re Contingent Fees														(G) Affidavit re Contingent Fees			
(H) Bid Bond														(H) Bid Bond			
(I) Current Business License														(I) Current Business License			
TABULATED BY: <i>R. JOYCE CASTRO</i>		(Signature)		DATE: <i>11/15/19</i>													

EXHIBIT B

Starcraft Bus

Pre-Award BUY AMERICA CERTIFICATION

This certifies compliance with FTA Buy America Regulations set forth in 49 C.F.R. § 661.11 for each component that more than 70% of the subcomponents, by cost, are of U.S. origin/manufacture and is manufactured in the U.S. Manufacturer attests that the U.S. content of subcomponents, by cost is as indicated below.

COMPONENT NAME	MANUFACTURER NAME		% U.S. CONTENT	% FOREIGN CONTENT
ALLSTAR 25' 177"WB GMC Savana 4500	Starcraft Bus		73.49%	26.51%
SUBCOMPONENT NAME	MANUFACTURER NAME	MFG LOCATION	% OF TOTAL	
Chassis	General Motors	U.S.	38.48%	
Air Conditioning	Trans Air	U.S.	4.54%	
WheelChair and/or Rear Door	Challenger Door	U.S.	1.66%	
Wheelchair Lift	Braun	U.S.	5.19%	
Wheelchair Securements	Q'Straint	U.S.	1.63%	
Exterior Mirrors	ROSCO	U.S.	0.24%	
Seating	Freedman Seating	U.S.	6.66%	
Destination Signs	Transign	U.S.	4.24%	
Rear Suspension	Mor/Ryde	U.S.	0.80%	
Bike Rack	Sportworks	U.S.	2.35%	
Farebox	Diamond MFG	U.S.	1.89%	
Roof Hatch	Transpec	U.S.	0.23%	
Electric System	LGS Group	U.S.	1.29%	
Car Body	Starcraft Bus	U.S.	2.34%	
Labor/Overhead/Profit	Starcraft Bus	U.S.	1.95%	

MAJOR ACTIVITIES UNDERTAKEN AT THE FINAL ASSEMBLY LOCATION

All purchasing of raw and assembled materials including the chassis, fabrication and welding of the frame, prime paint, installation of all wood, fabric, FRP, aluminum and/or other body panel and/or trim materials, installation of doors and windows, HVAC components and systems, electrical systems, installation of any required options such as wheel chair lifts, tie down kits, seats, radios and optional electronic items, if any, complete undercoat, exterior paint and/or graphics if ordered, full road test, rain booth test and all other final quality functions as needed to ensure compliance with the contract.

FINAL ASSEMBLY LOCATION: 2367 CENTURY DRIVE, GOSHEN, IN 46528

BODY V.I.N. OF UNITS DELIVERED UNDER POST DELIVERY BUY AMERICA:

TBD

FINAL ASSEMBLY % OF TOTAL COST NOT INCLUDED IN THE MATERIAL COSTS ABOVE:

FINAL ASSEMBLY \$\$ NOT INCLUDED IN THE COSTS ABOVE

4.55%

\$2,456.27

AUTHORIZED SIGNATURE

Government Bids
TITLE

2/17/2020
DATE

Scott Defrees
PRINT NAME

SPECIFICATIONS:

Wheelchair Stations:

Four (4) stations with one (1) dedicated station with lift located curbside beside front entrance forward facing

4-point wheelchair tie-downs with fully automatic retractors including fixed securement anchorage capable of 360 degree rotation which allows one-handed securement with both visual and audible positive locking indicators

Belt system forward facing with auto-retractable lap/shoulder restraint attached to sidewall of bus (ref. Q'Strain QRT MAX, Sure-Lok)

Wheelchair belts storage: tie-down storage system (TDSS)-attached under folding seats with spring shield on bottom of seats

Written and video instructions on how to use lap and shoulder restraints

Mirrors:

Interior 6" x 16" minimum convex rear view mirror mounted (Unobstructed View of seating)

Black Injection molded Acrylonitrile butadiene styrene (ABS) head minimum 9.05" W x minimum 13.62" H, dual exterior mirrors with a separate full-width minimum 8" W x minimum 4" H convex lower glass panel, power remote with heat complete with mounting base and upper arm to be provided

Sun Visor:

Provided on driver's side

Gauges and Lamps:

- Speedometer
- Odometer
- Voltmeter
- Oil pressure gauge
- Fuel capacity gauge
- Water temperature gauge
- Headlight indicator light
- High beam light indicator light
- Left/Right turn indicator light
- Emergency flasher warning
- Parking brake warning light
- Door ajar indicator light
- Passive lift control console

ELECTRICAL:

Automatic Fast Idle System manually and automatically elevates the vehicle's revolutions per minute (RPM) to 3 (three) customizable speeds.

The system shall automatically engage if the battery voltage drops below 12.5 volts

Maximum available alternator from the manufacturer with a minimum of 220 amps

Batteries, heavy duty dual 1200 CCA total (minimum), 2nd battery located in accessible sealed fiberglass box mounted on stainless steel track at passenger side skirt

BIDDING ON/REMARKS:

per spec



per spec

per spec

per spec

per spec

per spec

per spec

per spec

per spec

per spec

per spec

per spec

per spec

per spec

per spec

per spec

per spec

LEGEND
 (35) = C/L FRONT AXLE TO PASS C.G.

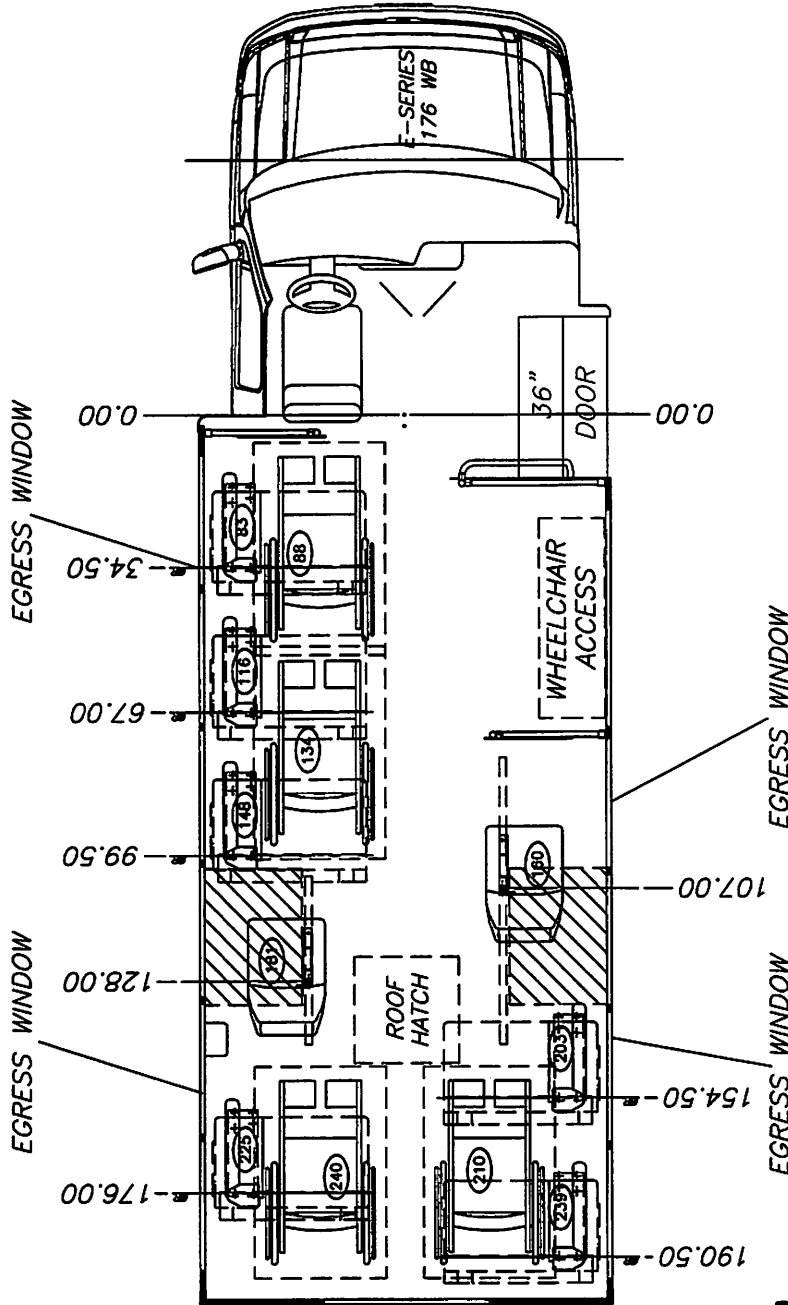

DEALER APPROVAL
 APPROVED
 X CUSTOMER SIGNATURE

ELDERADO REVGROUP		1655 WALL STREET SALINA, KS. 67401	
TITLE: ADVANTAGE 240 3.0 36" ENTRY DOOR / WC DOOR (FRONT)		UNIT NUMBER AVF2408-GA02	
DRAWING INFORMATION		RELEASE TO PRODUCTION	
DRAWN: MILLER CKD:	DATE: 1/3/19	REV. BY	DATE
SIZE: A	SCALE: 1/42	JPM	1/3/19
TOLERANCE UNLESS SPECIFIED			
SEAT SPACING ± .25 (SEAT SPACING NOT TO BE LESS THAN 28.5")			
RESTRAINTS ± .25 (W/C POSITIONS NOT TO BE SMALLER THAN 30 X 48)			
PAGE		1 OF 1	

**Forest River, Inc.**

55470 County Road 1, P.O. Box 3030, Elkhart, Indiana 46515-3030 • 574-389-4600 • Fax 574-296-7558

January 24, 2019

To: All Forest River Bus Dealers

From: Jerry Cavanah

Re: Federally Funded Purchases of Units on General Motors Cutaway Chassis

Since the 2016 Model year, the domestic content of GM cutaway chassis has declined from 68.989% to the current 55.695% level. Meanwhile, the domestic content threshold has increased on federally funded purchases from 60% of material cost to 65%. It will again increase to 70% October 1, 2019.

These factors have made the use of GM chassis for federally funded purchases tenuous and, as a result forced a new policy on potential orders for these federally funded purchases. That new policy is this:

Any request for purchase of a vehicle on a GM chassis cannot be considered an order. As such you should not accept purchase orders from a customer until a quote has been sent to the proper Forest River Bus division for a Buy America compliance review. Upon completion of the review we will advise whether or not the quoted build will meet the Buy America domestic content threshold. If it does, you will be authorized to accept an order from the end user and submit it to Forest River Bus for processing. If it does not, we will inform you that no order will be accepted if Federal Funding is used.

We urge you to advise your clients of this change immediately.

We apologize for the need to implement this policy; however, neither you, your client nor we have any control over the domestic content change in the chassis.

***** UPDATE*****

We wanted to provide a clarification regarding the timeline for the previously mentioned Buy America compliance reviews. The reviews on orders with GM chassis must take place before March 1, 2019. The chassis also must be ordered by the same March 1, 2019 deadline. The reason for this deadline is to account for chassis arrival, production scheduling, vehicle build and delivery. All of that must occur prior to Oct. 1, 2019 to avoid the 70% threshold. After this March 1, 2019 deadline, GM chassis will not be considered on FTA-funded vehicle purchases due to the new 70% domestic content requirement.

If you should have any questions, please reach out to your sales rep.

Sincerely,

Jerry Cavanah, Government Bids



TO: All Eldorado Dealers
FROM: Eldorado Sales Team
DATE: March 9, 2020
RE: Buy America – GM cutaway chassis

As the domestic content of the GM cutaway chassis continues to decline and the domestic content requirements from FTA have increased, Eldorado National (Kansas), Inc. will no longer be able to certify any orders built on a GM cutaway chassis for federally funded units as they will not meet Buy America requirements.

We apologize for any inconveniences this may cause. Please contact your Regional Sales Manager if you have any questions.

ELDORADO NATIONAL, (KANSAS), INC. DEALER SALES AGREEMENT

This Agreement, effective this 21st day of August, 2017 and between EIDorado National, (Kansas), Inc. as the manufacturer of World Trans Buses (hereinafter referred to as "EIDorado"),

and,

DEALER LEGAL NAME Soderholm Sales And Leasing
 DEALER COMPLETE ADDRESS 2044 Dillingham Blvd
 CITY, STATE, ZIP Honolulu, HI 96819
 PHONE 808-834-1417

Which is: a proprietorship, a partnership, a corporation, or a limited liability company, incorporated in the State of Hawaii (hereinafter referred to as "Dealer")

DEFINITIONS

1. **Agreement** - This Dealer Sales Agreement, herein to include; the Dealer Data Sheet attached hereto, any subsequent Dealer Data Sheet, Bulletins, and those sales, service, and other requirements that EIDorado reasonably imposes upon Dealer from time-to-time.
2. **Area of Primary Responsibility** - The geographic area designated by EIDorado, if any, in the Dealer Data Sheet attached to this Agreement.
3. **Dealer** - The corporation, partnership, limited liability company, or proprietorship that signs the Dealer Data Sheet attached to the Dealer Sales Agreement ("Agreement").
4. **Dealer Data Sheet** - The Dealer Data Sheet identifies the specific terms and conditions related to the Area of Responsibility (AOR), Sales Performance Criteria, Stocking Levels for the EIDorado Products identified within the Dealer Data Sheet.
5. **Dealer Operator** - Principal manager of Dealer identified in Article II, whose involvement in the day-to-day operations of the Dealer is relied upon by EIDorado in entering into the Agreement.
6. **Dealer Owner** - Owner of Dealer identified in Article II, whose involvement in the overall direction and governance of the Dealer is relied upon by EIDorado in entering into the Agreement.
7. **Dealer Sales Location** - The Dealer location(s) approved by EIDorado for the purpose of conducting Dealer Operations.
8. **Dealer Operations** - All operations contemplated by the Agreement. These operations include, but are not limited to, sale and service of Products and any other activities undertaken by Dealer related to Products, including used vehicle sales, body shop operations, finance and insurance operations whether conducted directly or indirectly by Dealer.
9. **Dealer Premises** - Approved facilities provided by Dealer at its Dealer Location for the conduct of Dealer Operations.
10. **EIDorado Vehicles** - The EIDorado vehicle line(s) of products set forth on the Dealer Data Sheet attached hereto.
11. **EIDorado Vehicle Dealers** - Dealers that are a party to an Agreement with EIDorado for a line of products.
12. **Marks** - The various trademarks, service marks, names and designs used by EIDorado.
13. **Parts and Accessories** - New or remanufactured EIDorado Vehicle parts and accessories marketed by EIDorado.
14. **Products** - EIDorado Vehicles and Parts and Accessories. Products shall exclude all such products, parts, and accessories, as are from time-to-time, discontinued, changed, or replaced by EIDorado whether with or without notice to the Dealer.
15. **Released-to-Production** - Status of a vehicle order that occurs when the order is selected at the assembly plant for production.
16. **Sales Performance Criteria** - The sales objectives for the Dealer in the Dealer's Area of Primary Responsibility.
17. **Special Vehicles** - EIDorado Vehicles that have limited marketability because they differ from EIDorado's standard specifications or incorporate special equipment.
18. **Financing** - To be an established Dealer for EIDorado, the Dealer must have in place a wholesale financing program when ordering any vehicle. Any other method of financing the vehicle is at the discretion of EIDorado. Failure to provide a wholesale financing could result in loss of your Dealer Agreement.

PURPOSE

The purpose of this Agreement is to establish Dealer as an authorized dealer for EIDorado Vehicles, to establish the location(s) from which the Dealer will conduct Dealer Operations, and to identify the individual Dealer Operator and Dealer Owner upon whom EIDorado relies in entering into this Agreement, each as indicated on the Dealer Data Sheet attached hereto. This is a personal service contract setting forth the rights and obligations of Dealer and EIDorado relating to the sale and service of EIDorado Products.

Accordingly, the parties agree as follows:

ARTICLE I. RIGHTS GRANTED TO DEALER

EIDorado grants the Dealer a non-exclusive right to:

- (a) buy new EIDorado Products; and
- (b) identify itself as an authorized dealer of EIDorado Products at the locations approved by EIDorado as noted in the Dealer Data Sheet attached to this Agreement.

Dealer accepts the rights granted by EIDorado and agrees to:

- (a) effectively sell and service EIDorado Vehicles; and
- (b) build and maintain consumer confidence in Dealer and EIDorado; and
- (c) establish and maintain satisfactory Dealer Premises at the Dealer Sales and Service Locations.
- (d) To make available to EIDorado all the information as required by EIDorado to support and partner with the dealer. To make all pertinent details of the bid process available and assist in being successful at the conclusion of the bid award.

Dealer has not paid any fee for this Agreement. Neither this Agreement, nor any right granted by this Agreement, is a property right. Neither this Agreement nor any right or responsibility under this Agreement may be transferred, assigned, delegated or sold by Dealer.

ARTICLE II. MANAGEMENT AND OWNERSHIP OF DEALER

EIDorado is entering into this Agreement in reliance on the qualifications and capabilities of the person(s) identified in the Dealer Data Sheet attached to this Agreement as Dealer Operator, and on the Dealer's assurance that the personal services of the Dealer Operator will be provided in the Dealer Operations. Dealer represents that the Dealer Operator will be the principal manager of Dealer, and the Dealer Owner will be the principal owner of the Dealer.

EIDorado and Dealer agree that the Dealer Operator will actively exercise full management authority in the Dealer Operations, and that all owners of Dealer will each continue to own, both of record and beneficially, the Dealer Business.

ARTICLE III. TERM

This Agreement shall continue to be effective for a period of one (1) year from the date of this Agreement, and continue thereafter until terminated pursuant to Article VII of this Agreement. The existing Dealer Data Sheet will expire on October 31st of each year unless replaced by EIDorado. If no new Dealer Data Sheet is mutually agreed to by EIDorado and Dealer before October 31st of the current year, then the existing Dealer Data Sheet will remain in effect and carry over.

ARTICLE IV. SALES TO DEALER

A. Dealer Data Sheet

EIDorado has furnished to Dealer the Dealer Data Sheet (attached hereto) specifying relevant information with respect to the Dealer and EIDorado. The executed Dealer Data Sheet shall control those EIDorado Products for which Dealer has an active Agreement to sell. The executed Dealer Data Sheet for this Agreement, and any subsequent Dealer Data Sheets with respect to EIDorado Vehicles, shall be a part of this Agreement and shall control those Products to which this Agreement relates.

The Dealer Data Sheet shall be an integral part of this Agreement between EIDorado and Dealer and may be amended from time-to-time by EIDorado, which amendments shall be binding upon Dealer unless Dealer has a reasonable objection and sets forth such objection in writing within seven (7) days following receipt of the amendment.

Dealer and EIDorado agree to periodically review the inventory levels, goals, and objectives set forth in the Dealer Data Sheet.

B. Processing of Dealer's Orders

1. When Orders Binding

Dealer's orders for new EIDorado Vehicles and other Products are not binding on Dealer or EIDorado until order is accepted and released into production. The order may be canceled by the Dealer until that time. Once formal acknowledgement and acceptance of Dealer's order by EIDorado, the order is released into production and now becomes a binding agreement between Dealer and EIDorado.

2. Required Equipment

EIDorado may install, and charge, for any equipment or accessories required by law and/or contractual obligations on any EIDorado Vehicles ordered by Dealer, whether or not such items are included in Dealer's order.

3. Cancellation of Order

EIDorado may, at its election, permit Dealer to cancel a binding order for a Special Vehicle, in which case Dealer may be charged for EIDorado's labor and material incurred up to the time EIDorado accepts the cancellation.

C. Prices and Other Terms of Sale

1. Prices, destination charges, and other terms of sale, to purchase new Vehicles by Dealer from EIDorado will be at the discretion of EIDorado.
2. Prices, destination charges, and other terms of sales applicable to any EIDorado Vehicles may be changed by EIDorado at any time. Except as otherwise provided by EIDorado in writing, such changes will apply to Vehicles not shipped at the time such changes are made effective.
3. Dealer will buy Products directly from EIDorado and resell them at market price. Direct sales will conform to EIDorado standard practices and terms and conditions of sale. All efforts and expenditures of the Dealer in bringing about a sale, contributing to the performance under the transaction, in performing any pre-delivery inspection, as well as any expenses incurred by the Dealer in connection with the performance of this Agreement, shall be deemed to be compensated by the difference between the price paid by Dealer to buy the vehicle from EIDorado and the price at which the Dealer resells or leases the vehicle. No consideration shall be paid to Dealer for Products that are delivered by EIDorado into the Dealer's Area of Primary Responsibility.

D. EIDorado Vehicle Delivery

1. Shipping

Risk of loss and title to EIDorado Products pass to Dealer FOB EIDorado's manufacturing facility. Dealer may pick up vehicles or select alternative modes of transportation and will assume all responsibility therefor.

2. Dealer Claims for Shipping Damages

Dealer claims for loss or damage to EIDorado Vehicles, while in the possession of a carrier, must be submitted by Dealer to the carrier. Dealer shall give written notice to EIDorado of any claims it makes to a carrier, and provide such further information requested by EIDorado.

3. Insurance.

Dealer agrees to insure the Products at Dealer's expense, from the time of delivery of the Product to a carrier at EIDorado's place of business for shipment to Dealer and thereafter against loss or damage in a minimum amount equal to the price to be paid to EIDorado for those Products. This insurance policy will name EIDorado as additional insured, and provide that in the event of loss the insurer will pay to the insured as their interest may appear and Dealer will furnish to EIDorado certificates of insurance which shall provide for ten (10) days prior written notice to EIDorado of cancellation.

E. Warranties on Products

DEALER WILL PROVIDE THE END RETAIL PURCHASER WITH ELDORADO'S STANDARD LIMITED WARRANTY FOR THE ELDORADO VEHICLES, AND SHALL PASS-THROUGH ANY ASSIGNABLE WARRANTIES ISSUED BY THIRD-PARTY COMPONENT MANUFACTURERS.

EXCEPT AS STATED IN THE FOREGOING PARAGRAPH, EIDorado DISCLAIMS ANY EXPRESS OR IMPLIED WARRANTIES ON ITS PRODUCTS, INCLUDING, BUT NOT LIMITED TO, ANY WARRANTIES OF MERCHANTABILITY OR FITNESS FOR A PARTICULAR PURPOSE OR ANY WARRANTY ARISING FROM COURSE OF DEALING OR USAGE OF TRADE. TO THE EXTENT THAT ANY IMPLIED WARRANTIES MAY NOT BE DISCLAIMED, SUCH WARRANTIES ARE EXPRESSLY LIMITED TO THE DURATION OF THE EXPRESS WARRANTY STATED BY EIDorado FOR ITS PRODUCTS. DEALER'S EXCLUSIVE REMEDY AND EIDorado LIMIT OF LIABILITY FOR ANY AND ALL WARRANTY CLAIMS HEREUNDER, SHALL BE FOR THE PURCHASE PRICE OF THE PARTICULAR PRODUCTS WITH RESPECT TO WHICH SUCH CLAIMS ARE ASSERTED, PLUS ANY TRANSPORTATION CHARGES ACTUALLY PAID BY DEALER ATTRIBUTABLE TO SUCH PRODUCTS.

LIMITATION ON LIABILITY. EIDorado SHALL NOT BE LIABLE FOR INDIRECT, SPECIAL, INCIDENTAL, CONSEQUENTIAL, OR PUNITIVE DAMAGES RESULTING FROM THE USE OF THE PRODUCTS OR ARISING OUT OF ANY BREACH OF ANY OF THE WARRANTIES PROVIDED BY EIDorado OR ANY BREACH BY EIDorado OF ANY OF ITS OBLIGATIONS UNDER THIS AGREEMENT OR APPLICABLE LAW.

Dealer agrees that it shall not make any warranties or representations to its retail customers as to the EIDorado Products and shall properly disclaim all express and implied warranties at the time of retail sale.

F. Consequential Damages

EIDorado shall not be liable to Dealer for, and hereby disclaims, any and all consequential and incidental damages, including but not limited to lost profits, finance charges, interest incurred, and downtime.

G. Excusable Delay or Failure to Fill Orders or Accept Shipments

1. Delay in Delivery

EIDorado will not be liable for any delay or failure to deliver Products where such delay or failure is caused, in whole or in part, by:

- (a) any strike or labor trouble affecting operations of Dealer, EIDorado, or its suppliers;
- (b) any shortage or curtailment of utilities, materials, transportation or labor or any shortage or damage of productive facilities;
- (c) any act of government, including the enactment of laws or regulations or issuance of judicial or administrative injunctions or orders;
- (d) any curtailment of production due to economic conditions; or any discontinuance of manufacture or sale by EIDorado; or
- (e) any cause beyond the control of EIDorado.

In the event EIDorado is unable to complete delivery of EIDorado Products as a result of one of the above causes, within thirty (30) days following the end of such cause, Dealer shall be relieved of its obligation to purchase such EIDorado Products.

2. Dealer's Delay Liability

If any EIDorado Products ordered by Dealer are diverted or returned because of Dealer's unexcused delay or failure to accept delivery, Dealer will pay any additional costs incurred by EIDorado as a result of such diversion.

H. Discontinuance of and Changes in Products

EIDorado may discontinue, with notice to Dealer, any EIDorado Product at any time and its only obligation shall be to manufacture and deliver to Dealer accepted orders, which Dealer does not elect to cancel. EIDorado may change the design or specifications of any EIDorado Product without notice to Dealer.

ARTICLE V. DEALER OPERATIONS

A. Responsibility of Dealer

1. Dealer Premises

Dealer shall provide facilities at the Dealer Premises that will enable Dealer to effectively perform and conduct its Dealer Operations. The Dealer Premises shall be satisfactory as to appearance and layout, and properly equipped to conduct Dealer Operations. Multiple premises may be required by mutual agreement.

2. Established Location

Dealer will conduct the Dealer Operations only from the Dealer Premises approved for that purpose by EIDorado and will not, either directly or indirectly, establish any place of business for the conduct of any of its Dealer Operations for the sale of EIDorado Products except at the approved Dealer Premises.

3. Changes in Location

If Dealer desires to make any changes in the Dealer Premises, Dealer agrees to give EIDorado written notice in sufficient advance such that EIDorado can discuss the effect of the proposed change with Dealer. No change in Dealer Premises will be made without the written approval of EIDorado.

4. **Signs**
Dealer will install and maintain in appropriate places at the Dealer Premises Product and service signs approved by EIDorado and such other signs as EIDorado and Dealer agree are appropriate to advertise the Dealer Operations.
5. **Licensing**
Dealer shall obtain and maintain any and all licenses required by the jurisdiction(s) in which it shall conduct Dealer Operations. Dealer shall promptly notify EIDorado of any change to its state or local licensing.
6. **Insurance**
Dealer shall purchase and maintain a comprehensive general liability insurance policy and garage liability policy each with limits of not less than \$1,000,000 per occurrence and \$1,000,000 in the aggregate with EIDorado as an additional insured on such policies. Such insurance shall have a deductible of no more than \$25,000, and shall be placed with an insurance company acceptable to EIDorado and licensed to do business in the state where Dealer is located. The policies shall include, by endorsement if necessary, thirty (30) days prior written notice to EIDorado of cancellations, material changes, or reduction in coverage. Dealer shall provide EIDorado with a certificate evidencing the required insurance.

B. Sales Performance

1. **Responsibility of Dealer**
Dealer is responsible in Dealer's Area of Primary Responsibility for:
 - (a) actively and effectively selling new EIDorado Vehicles;
 - (b) actively and effectively promoting, through Dealer's own advertising and sales promotion activities, the purchase and use of new EIDorado Vehicles; and
 - (c) meeting or exceeding the Sales Performance Criteria set forth in the Dealer Data Sheet

The Area of Primary Responsibility for the Dealer has been designated in the Dealer Data Sheet attached to this Agreement. The parties agree that the Dealer Data Sheet may be changed from time to time and that the current Dealer Data Sheet is a part of this Agreement.

2. **Sales Operations and Activities of Dealer**
In furtherance of the objectives of this Agreement, Dealer agrees to:
 - (a) maintain an adequate force of EIDorado-trained sales personnel;
 - (b) maintain a high standard of ethical advertising and sales activities in promoting its Dealer Operations;
 - (c) explain to EIDorado Product purchasers the items which make up the purchase price; and give them itemized invoices and any other information required by law;
 - (d) refrain from making any misleading statements concerning the nature or amount of items making up the total selling price of a EIDorado Vehicle;
 - (e) not charge customers for any services for which Dealer is reimbursed by EIDorado, such as for pre-delivery inspections and adjustments;
 - (f) include equipment or accessories required by customer or required by law; and
 - (g) maintain a mutually agreed stocking level of demonstrator vehicles as noted in the Dealer Data Sheet.

3. **Modifications by Dealer**

If Dealer modifies a new EIDorado Vehicle, or installs any equipment, accessory, or part that has not been supplied by EIDorado, or sells any EIDorado Vehicle that has been modified, or sells any non-EIDorado service contract in conjunction with the sale of the vehicle, Dealer will disclose this fact to the purchaser and will advise the purchaser that the modification, equipment, accessory or part is not included in the limited warranty furnished by EIDorado.

It is the responsibility of the Dealer to provide a written disclosure on the purchase order or sales agreement when third-party accessories, modifications, service contracts, or other non-factory additions to EIDorado Products. This shall provide written acknowledgement that the disclosed items are not to be covered by EIDorado Warranty.

4. **Evaluation of Dealer's Sales Performance**

Dealer's sales performance will be evaluated by EIDorado on the basis of Dealer's sales and market penetration effectiveness, as well as any other factors deemed appropriate by EIDorado. Subject to applicable law, EIDorado shall, in its discretion, determine the adequacy of the Dealer's sales performance, and may terminate this Agreement for inadequate sales performance by written notice to Dealer. Inadequate sales performance shall be determined by the mutually agreed to Dealer Data Sheet.

C. **Service Performance**

Dealer is required to provide a service plan for EIDorado Products. It shall be the responsibility of the Dealer to ensure that the end-user has mutually acceptable access to an authorized EIDorado warranty facility.

For Dealer to provide warranty services on EIDorado Products, it is required that the Dealer is party to a REV Bus Service and Warranty Agreement.

D. **License to Use Trademarks and Service Marks**

EIDorado hereby licenses to Dealer the right to use such trademarks and trade names as registered by EIDorado from time to time (collectively the "Licensed Marks") in the conduct and performance of this Agreement and to use the Licensed Marks in Dealer's corporation, firm, or trade name with prior written approval of EIDorado.

Subject to revocation by EIDorado at any time, the Dealer shall be permitted to use the trademarks "EIDorado" and other trademarks registered in EIDorado name for advertising and promotional purposes, provided that the Dealer observes the applicable EIDorado directives and uses only those trademark designs approved in writing in advance by EIDorado.

Dealer shall not register, secure, purchase or otherwise acquire the name "EIDorado", or any of the other trade names or trademarks of EIDorado; including any confusingly similar names or marks, as URL, internet listing, search term or web based identification mark.

Upon termination of this Agreement, the Distributor shall immediately cease to use in any manner whatsoever the name EIDorado and all trademarks of Capacity.

It is understood by and between the parties that EIDorado may revoke this license at any time upon notice to Dealer.

E. **Establishment of Additional Dealers**

EIDorado reserves the right to appoint additional EIDorado Vehicle Dealers. This right will not be exercised without analyzing marketing factors in the area of a possible new Dealer location.

Notwithstanding any other provision of this Agreement, the final decision whether to establish an additional dealer shall be made by EIDorado solely pursuant to its own business judgment and nothing in this Agreement shall be construed to require Dealer's consent to the establishment of an additional dealer.

ARTICLE VI. RIGHTS OF ELDORADO

A. Selection of Dealers

The parties recognize that EIDorado Vehicles are marketed through a system of authorized dealers developed by EIDorado and that customers, authorized dealers, and employees of EIDorado shall perform such responsibility as set forth in Article V on the basis of evaluating each candidate's qualifications and proposal for the conduct of Dealer operations against the standards set forth in this Agreement.

Accordingly, EIDorado has the right to select each successor and replacement dealer and to approve its dealer operators and owners and the location of its Dealer facilities. EIDorado shall perform such responsibility as set forth in Article V on the basis of evaluating each candidate's qualifications and proposal for the conduct of Dealer operations against the standards set forth in this Agreement.

ARTICLE VII. TERMINATION

A. Termination of Agreement

1. Termination by Dealer

Dealer may terminate this Agreement by written notice to EIDorado. Termination will be effective thirty (30) days after EIDorado's receipt of the notice unless otherwise mutually agreed in writing.

2. Termination by EIDorado

EIDorado may terminate this Agreement at any time at its election, for one of the reasons set forth in Section VII(A)(4), VII(A)(5) or VII(A)(6), or for breach of another term of this Agreement, by notice in writing given to the Dealer specifying the date of termination which date will not be less than thirty (30) days after the date of said notice, or under such other circumstances as provided by law.

3. Termination by Agreement

This Agreement may be terminated at any time by written agreement between EIDorado and Dealer.

4. Termination for Failure to be Licensed

If EIDorado or Dealer fails to secure or maintain any license required for the performance of its obligations under this Agreement, or such license is suspended or revoked, irrespective of the cause, either party may immediately terminate this Agreement by giving the other party written notice.

5. Termination Because of Incapacity of Dealer Operator

Because of the personal service nature of this Agreement, EIDorado may terminate this Agreement by written notice to Dealer if Dealer Operator is so physically or mentally incapacitated that the Dealer Operator is unable to actively exercise full managerial authority. The effective date of termination will be stated in such written notice and will be not less than thirty (30) days after receipt of such notice.

6. Termination Due to Certain Acts or Events

The acts or events described below are within the control of Dealer or originate from action taken by Dealer or its management or owners and which are so contrary to the spirit and objectives of this Agreement as to warrant Dealer's termination:

- (a) Failure to meet sales objectives in Dealers Area of Primary Responsibility or otherwise maximize sales of EIDorado vehicles and products.
- (b) The removal, resignation, withdrawal or elimination from Dealer for any reason of any Dealer Operator or Dealer Owner without prior written notice to EIDorado.
- (c) Any attempted or actual sale, transfer or assignment by Dealer of this Agreement or any of the rights granted Dealer hereunder, or any attempted actual transfer, assignment, or delegation by Dealer of any of the responsibilities assumed by it under this Agreement contrary to the terms of this Agreement.
- (d) Any change, whether voluntary or involuntary, in the record or beneficial ownership of Dealer as set forth in Article II of this Agreement.
- (e) Any undertaking by Dealer or any of its owners to conduct, either directly or indirectly, any of the Dealer Operations at any unapproved location.

- (f) Any sale or other transfer, by operation of law or otherwise, or any relinquishment or discontinuance of use by Dealer, of any of the Dealer Premises or other principal assets required in the conduct of the Dealer Operations, without prior written notice to EIDorado.
- (g) Refusal by Dealer to timely furnish sales, service or financial information and related supporting data or to permit EIDorado to make an examination of Dealer's accounts and records.
- (h) A finding by a government agency or court that Dealer, or predecessor of Dealer owned or controlled by the same person, has engaged in any act or business practice which, in the opinion of EIDorado, involves an act of moral turpitude or breach of trust that may adversely affect the reputation or interest of Dealer or EIDorado.
- (i) Willful failure of Dealer to comply with the provisions of any laws or regulation relating to the sale or service of Products.
- (j) Submission by Dealer of false applications or claims for any payment, credit, discount or allowances (including false applications in connection with incentive activities) or of false orders for Products or reports of delivery or transfer of Products, whether or not Dealer offers or makes restitution.
- (k) Dealer or key personnel are convicted of a criminal offense related to or affecting the business conducted pursuant to this Agreement.
- (l) Insolvency of Dealer, filing of a voluntary petition in bankruptcy by Dealer, filing of a petition to have Dealer declared bankrupt or appointment of a receiver or trustee for Dealer, provided such ruling or appointment is not vacated within thirty (30) days; or execution by Dealer of an assignment for the benefit of creditors or any foreclosure or other due process of law whereby a third party acquires rights to the operations, ownership, or assets of Dealer.
- (m) Failure of Dealer to conduct its customary sales and service operations during customary business hours for seven (7) consecutive business days.
- (n) Any misrepresentation to EIDorado by Dealer or by any Dealer Operator or Owner in applying for this Agreement, or as to the record or beneficial ownership of Dealer.

7. **Reliance on any Applicable Termination Provision**
 The terminating party may select the termination provision under which it elects to terminate without reference in its notice of termination to any other provision that may also be applicable. The terminating party may also subsequently assert other grounds for termination.

B. Transactions After Termination

1. **Effect of Termination on Orders**
 If Dealer and EIDorado do not enter into a new Agreement when this Agreement terminates, all of Dealer's outstanding orders for Vehicles and Products will be automatically canceled, except as provided in this Article VII.
 B.
 Termination of this Agreement will not release Dealer or EIDorado from the obligation to pay any amounts owing the other, nor release Dealer from the obligation to pay for Special Vehicles if EIDorado orders prior to the effective date of termination.
2. **Termination Deliveries**
 If this Agreement is voluntarily terminated by Dealer, or expires or is terminated because of the death or incapacity of a Dealer Operator or death of a Dealer Owner, without a termination or expiration deferral date, EIDorado will exert its best efforts consistent with its distribution procedures to furnish Dealer with Vehicles to fill Dealer's bona fide retail orders on hand on the effective date of termination or expiration.
3. **Effect of Transactions After Termination**
 Neither EIDorado's sale of Products to Dealer nor any other act by EIDorado or Dealer after termination of this Agreement will be construed as a waiver of the termination.
4. **Dealer's Responsibility Upon Termination**
 Dealer will cease to operate, and will no longer represent EIDorado, as an authorized Dealer and will discontinue use of any identification which associates Dealer with EIDorado.
 Dealer will remove all signs and advertising displays bearing the EIDorado Company name and any other trade

names or trademarks of EIDorado or any of its affiliated companies from Dealer's business establishment, and thereafter will not use such names and trademarks in connection with any business conducted by Dealer.

Dealer will immediately return, and deliver to EIDorado, all originals, copies, excerpts or derivatives in Dealer's possession of software, catalogs, price lists, service manuals, bulletins, owner's manuals and current advertising material and other material or literature relating to the sale, merchandising, operating or servicing of Products which were furnished to Dealer by Company. Any charges, except for transportation, paid by Dealer to EIDorado for such material will be credited to Dealer when such material is received by EIDorado.

Dealer agrees to deliver to EIDorado all photocopies of all sales records, ownership lists, service history records and any other material of any kind relating to the sale, operation or servicing of Products, including repair parts, covered by this Agreement. EIDorado will pay Dealer's reasonable expenses in complying with this provision.

Neither EIDorado, nor Dealer shall be liable to the other for any special or consequential damages caused by the termination of this Agreement whether or not they have been advised of the possibility of such losses, including those damages based on loss of anticipated sales or prospective profits, expenditures or investments.

ARTICLE VIII. INDEMNIFICATION

EIDorado shall indemnify, defend, and hold harmless Dealer, its officers, directors, agents, employees, and assignees, from and against claims, actions, damages, liabilities, obligations, and costs (including attorney's fees) ("Damages") arising out of or relating to: (1) bodily injury, death, disease, or sickness to persons or damage to property caused by an actual defect in EIDorado's design, manufacture, or assembly of any EIDorado Product, that could not have been detected by Dealer by a reasonable inspection thereof; and (2) failure of any EIDorado Product, or any standard equipment or material component thereof, to conform to written representations or warranties made by EIDorado to Dealer's customer and allegedly relied upon by Dealer's customer, which representations and warranties may be limited or changed by written notice from EIDorado to Dealer prior to the date of the delivery of the EIDorado Product to such customer. EIDorado's indemnification obligations hereunder shall not apply when Damages arise out of or result from defects or failures in components of EIDorado Products that are not manufactured or expressly warranty by EIDorado.

Dealer shall indemnify, defend, and hold harmless EIDorado, its officers, directors, agents, employees, and assignees, from and against claims, actions, damages, liabilities, obligations, and costs (including attorney's fees) arising out of or relating to: (1) Dealer's actual or alleged possession, repair, maintenance, operation, or use of any EIDorado Product, whether or not required of Dealer under this Agreement or otherwise; (2) Dealer's actual or alleged breach of any contract, agreement, statutory or regulatory requirement or other obligations between Dealer and its customer; and (3) Dealer's actual or alleged statements, representations, warranties (other than those warranties provided by EIDorado) or alleged unfair or deceptive acts or practices with respect to any of the EIDorado Product or Dealer's customers.

Dealer agrees to cooperate fully with EIDorado in the defense of any claim presented or litigation initiated by a customer involving EIDorado Product sold or serviced by Dealer.

EIDorado shall not be responsible under any circumstances for any punitive damages or statutory penalties assessed against the Dealer.

This section shall survive the expiration or termination of this Agreement.

ARTICLE IX. GENERAL PROVISIONS

A. No Agent or Legal Representative Status

This Agreement does not make either party the agent or legal representative of the other for any purpose whatsoever, nor does it grant either party any authority to assume or to create any obligation on behalf of or in the name of the other. Neither party owes the other any fiduciary obligation.

B. Independent Contractor

This Agreement does not create the relationship of principal and agent between EIDorado and Dealer and under no circumstances is either party considered the agent of the other.

C. Dealer's Responsibility for Its Operations

Except as provided otherwise in this Agreement, EIDorado has no liability in connection with the establishment or conduct of the Dealer Operations, and Dealer will be solely responsible for all expenditures, liabilities, and obligations incurred or assumed by Dealer in connection with Dealer's responsibilities under this Agreement.

D. Taxes

Dealer will pay all local, state, federal or other applicable taxes and file required tax returns related to its Dealer Operations and will hold EIDorado harmless from any claims or demands made by any taxing authority with respect thereto.

E. EIDorado Accounts and Special Vehicles

The Dealer agrees that EIDorado shall have the right of sale to public institutions and political subdivisions and to enter into EIDorado direct accounts, and also shall have right of sale of any and all Special Vehicles. EIDorado is not required to pay to Dealer a commission for units delivered in Dealer's Area of Primary Responsibility as a result of aforementioned sales.

Dealer shall service all such Vehicles in accordance with Article V.

F. Notices

Any notice required to be given by either party to the other in connection with this Agreement will be in writing and delivered personally or by mail. Notices to Dealer will be directed to Dealer, or its representatives, at Dealer's principal place of business, and notices by Dealer will be directed to:

EIDorado National, (Kansas), Inc.
Address: 1655 Wall Street, Salina, KS, 67401
Phone: 1.800.850.1287

G. No Implied Waivers

The delay or failure of either party to require performance by the other party, or the waiver by either party of a breach of any provision of this Agreement, will in no way affect the right to require such performance at any time thereafter.

H. Assignment of Rights or Delegation of Duties

Except as provided in this Agreement, neither this Agreement, nor the rights or obligations of Dealer, may be sold, assigned, delegated, or otherwise transferred without the prior written approval of EIDorado, and any attempted assignment in violation of this restriction shall be void and of no effect. EIDorado may assign this Agreement and any rights, or delegate any obligations, under this Agreement to affiliated or successor company and will provide written notice of any such assignment or delegation to Dealer. Any such assignment or delegation by EIDorado shall not relieve EIDorado of liability for the performance of its obligations under this Agreement.

I. Accounts Payable

In addition to any right of set-off provided by law, all monies or accounts due Dealer shall be considered net of indebtedness of Dealer to EIDorado, and EIDorado may deduct any amounts due or to become due from Dealer, or any sums or accounts due or to become due from EIDorado to Dealer.

J. Applicable Law

This Agreement is governed by the laws, without reference to conflict of law principles. However, if performance under this Agreement (or any term of this Agreement) is illegal under a valid law of any applicable jurisdiction, the performance (or that term) will be modified to the minimum extent necessary to comply with such law if it was effective on the date of execution of this Agreement.

K. Sole Agreement of Parties

Except as otherwise provided or referred to herein, EIDorado has made no promises to Dealer or any Dealer Operator or Owner, and there are no other agreements or understandings, either oral or in writing, between the parties affecting this Agreement or relating to any of the subject matter covered by this Agreement.

Except as otherwise provided herein, this Agreement cancels and supersedes all previous agreements between the parties that relate to any matters covered herein.

No agreement between EIDorado and Dealer, which relates to matters covered herein, and no change in, addition to (except the filling in of a blank line) or erasure of any printed portion of this Agreement, will be binding unless it is approved in a written agreement executed by the parties hereto.

L. Severability

Any part of this Agreement which is held to be invalid or unenforceable under the laws of any place where this Agreement is to be performed or is sought to be enforced shall be enforceable to the maximum extent permitted by law, without invalidating its effect elsewhere and without affecting the remainder of this Agreement.

IN WITNESS WHEREOF, the parties hereto have executed this Agreement effective as the day and year first above written.

DEALER:

Signature: Denise L. Soderholm

Printed Name: Denise L. Soderholm

Title: Pres.

Date: 8-16-17

ELDORADO:

Signature: [Signature]

Printed Name: Colby Bertrand

Title: VP/AM

Date: 8/21/17



Forest River, Inc.
900 County Road 1 • Elkhart, Indiana 46514 • 574/389-4600

NEWS RELEASE

For immediate release Thursday, May 8, 2020

Forest River
900 County Road 1
Elkhart, Indiana 46514
Craig Koble
1-800-348-7440
ckoble@forestriverinc.com
www.forestriverinc.com

FOREST RIVER ANNOUNCES ACQUISITION OF ELDORADO NATIONAL (KANSAS) AND CHAMPION BUS

Elkhart, IND. – Forest River, Inc., one of America’s leading manufacturers of recreational vehicles, pontoon boats, cargo trailers and shuttle buses is pleased to announce the acquisition of REV Group’s shuttle bus businesses.

With a history dating back over 60 years, REV Group’s shuttle bus brands have a reputation for performance, product quality and unique features. With dealer locations throughout the United States and Canada, these businesses have a strong, tenured relationship with the commercial public sector.

David Wright, of Forest River, states, “We are excited to welcome Champion Bus and Eldorado to Forest River. Both organizations have built a history of integrity, quality and innovation and enjoy an excellent reputation in our industry today. As we navigate these challenging times, the addition of these historic and iconic brands to the Forest River family enhance our ability to provide products and a customer experience that is second to none. We look forward to working with our dealer partners as we better position Forest River’s shuttle bus divisions for the future.”

Forest River will acquire the following REV Group shuttle bus brands: Champion Bus, Federal Coach, World Trans, Krystal Coach, Eldorado and Goshen Coach. These brands are produced in Imlay City, MI and Salina, KS. This diverse product line provides convenient and dependable transportation for colleges, churches, assisted living facilities, retirement communities, transportation companies and government agencies.

For more information about REV Group or Forest River, Inc., please visit their websites at revgroup.com or forestriverinc.com.

FOREST RIVER BUS**DEALER AGREEMENT**

This agreement effective the 1st of August, 2020, is entered into between Forest River Inc., an Indiana Corporation, located at 900 County Road 1, Elkhart, IN 46514 (hereinafter known as "FR"), and Soderholm Sales & Leasing, Inc. (hereinafter known as "DEALERSHIP"). This agreement shall remain in effect annually between FR and Dealership unless terminated under section III of this agreement.

Whereas DEALERSHIP is desirous of selling products produced by Forest River Bus, (hereinafter known as "FRB") and whereas FR Hereby appoints DEALERSHIP as an authorized dealer of said FRB products, the following covenants shall govern this Dealer Agreement:

i. Undertakings by the DEALERSHIP

The DEALERSHIP agrees:

- A. To the following annual Operating Requirements, effective January 1st of each year, which are set forth in the signed Dealer Operating Requirements Addendum (DORA – attached addendum). The DORA provides an agreement between FR and DEALERSHIP regarding two minimum requirements which will be used to measure said DEALERSHIP's performance**
- 1. Minimum Sales Responsibility (MSR) – Dealer agrees to meet the Minimum Sales Responsibility (MSR) requirements established on a calendar year basis and set forth in the DORA. Dealer acknowledges that the MSR is an integral and material part of this Contract and that Dealer's failure to achieve the MSR may constitute grounds for termination of this Contract.**
 - 2. Minimum Inventory Requirement (MIR) – Dealer agrees to meet the Minimum Inventory Requirement (MIR) established on a calendar year basis and set forth in the DORA. Dealer acknowledges that the MIR is an integral and material part of this Contract and that Dealer's failure to achieve the MIR may constitute grounds for termination of this Contract.**
- B. To diligently advertise, promote, display and sell the products covered by this agreement throughout the described territory at the expense of the DEALERSHIP, including display in at least one (1) public show annually in the vicinity of the Dealership's place of business. It will actively follow up on all sales leads provided by FRB and cooperate with it in later evaluation of these leads. Further that it will fully utilize to the best of its ability all marketing aids and sales training programs offered by FRB to the DEALERSHIP. FRB will**

provide literature, ad slicks and/or other materials it may have available at its discretion.

- C. To completely and properly service each new vehicle before resale, and promptly remit to FRB the Retail Warranty Registration cards with the full name and mailing address of the purchaser of FRB products.
- D. To establish and/or maintain throughout the terms of the agreement adequate facilities for the products covered, including maintaining sufficient personnel to perform all services in strict adherence with the Repair and Maintenance instructions supplied by FRB.
- E. To abide by FR's conditions for payment for products purchased under this agreement, which may be established from time to time by notice from FR. At this time FR's terms are COD or pre-arranged floor plan and DEALERSHIP agrees to maintain lines of credit and/or floor plan instruments to accommodate agreed upon volumes herein defined in Paragraph I.A above.
- F. To make no representations or warranties as to FR products other than such warranties as are expressly set forth in FR's published warranty.
- G. To submit and utilize all forms or formats prescribed by FR for the purchase of products or parts or for warranty service performed in accordance with this agreement.
- H. To maintain a policy or policies of insurance with coverage for Worker's Compensation, General Liability of a minimum of \$ 1,000,000.00 and Auto Liability. DEALERSHIP shall provide proof of such insurance by way of a Certificate of Insurance naming FR as an additional insured and specifying thirty (30) days notice of cancellation or material changes in such insurance policy or policies.
- I. To indemnify, save and hold FR harmless from any liability whatsoever caused by the act or acts of DEALERSHIP and its agents, servants or employees. This indemnification shall include all of FR expenses including reasonable attorney fees. In like FR shall indemnify, save and hold harmless Dealership for any act or acts of FR agents, servants or employees, indemnification shall include all DEALERSHIP expenses including reasonable attorney fees.
- J. The DEALERSHIP agrees to keep an active site on the World Wide Web and display FRB products on said site and provide a link to the FRB site where practical.
- K. The dealership agrees they are responsible for meeting all transit bid specifications. Although FRB will assist during and after the bid process, they are not to be held financially accountable for missed specifications by the

dealer. The dealer will be responsible for additional cost that may be incurred due to specification errors on transit or contract bids.

II. Region

A. FR agrees to give DEALERSHIP the opportunity to promote and sell the Forest River Bus line within the assigned Area of Responsibility (AOR):

- 1. Dealership agrees to devote its best efforts to promote aggressively the sale of the Forest River Bus products covered by this Contract to customers within the assigned Area of Responsibility (AOR). To accomplish this objective, Dealer agrees to develop, maintain, and direct a competent sales staff and aggressively advertise the Forest River Bus product.**
- 2. Territories defined in this agreement shall be available to dealer within ninety (90) days of the signing of this agreement. Forest River Bus cannot restrict product coming into or out of assigned territories, but will work with the assigned dealer in regards to discounting of product.**

B. DEALERSHIP hereby acknowledges and agrees that the failure to maintain any of the above terms in Paragraph I may result in another dealer receiving priority in any or all of the assigned area(s) of responsibility.

III. Termination

If either party shall fail to observe his, their or its undertakings expressed in this agreement, the other party may give 30 days written notice of intent to cancel for any stated reason(s). Either party can terminate this agreement without cause with 60 days written notice. Either termination notice shall be sent to the other party by U.S. Certified Mail, postage prepaid, with return receipt requested. Notification of cancellation or termination will conform to the statutes required for the State of Indiana.

Any payments due FR from the DEALERSHIP are due and payable in full to FR on or before the expiration of five (5) days from the date of such termination. If such payments are not paid to FR within said time period, the balance due FR shall earn interest at the rate of 1 ½% per month.

Any change of ownership or controlling ownership of DEALERSHIP will automatically cancel this agreement. Re-issuance of a Dealer Agreement to subsequent owner(s) shall be at the discretion of FR and sufficient time and notice will be given to FR to investigate any new owner(s) before the issuance of a New Dealer Agreement.

IV. Delays and Damages

Company will not be liable if order deadlines are not met due to supply of chassis, other suppliers and/or vendors, labor situations, and other matters beyond our control, except where responsibility is specifically agreed.

V. General Terms

- A. Title to FRB products and parts remain with FR until full and complete payment is made for said products.
- B. DEALERSHIP is not an agent for FR in any respect, and has no authority to transact business in the name of FR or FRB or to incur any obligation or liability for or against FR.
- C. This agreement shall remain in full force and effect for a period of one (1) year, and shall be automatically renewed for successive one (1) year periods unless FR or DEALERSHIP gives sixty (60) days written notice of the intention not to renew this agreement, or it is terminated for just cause as found in the termination paragraph(s) stated in this agreement.
- D. This agreement replaces and supersedes all other and/or prior agreements between the parties whether written or implied. This agreement may not be modified unless in writing and signed by both parties hereto.
- E. This Contract shall be construed according to the laws of the State of Indiana, and if any provision of this Contract is declared unlawful or unenforceable, by judicial determination or otherwise, the remaining provisions of this Contract shall remain in full force and effect.

IN WITNESS WHEREOF, FR has caused this agreement to be properly and duly executed by its authorized officer; and the DEALERSHIP warrants the representative executing this agreement on its behalf is hereby fully authorized to do so.

FOREST RIVER, INC.

By: 

Date: 9/9/20

DEALERSHIP:

By: 

Date: 9-8-20

Dealer Operating Requirements Addendum
(DORA)

(Effective January 1 – December 31)

YEAR 2020

Dealership Name: Soderholm Sales & Leasing, Inc.
Address: 2044 Dillingham Blvd., Honolulu, HI 96819

Product Line: Forest River Bus Divisions

I. Area of Responsibility (AOR):

Dealer's Area of Responsibility (AOR) shall be:

Hawaii, Polynesia: Territory of Guam; Tonga; Samoa; American Samoa; Cook Islands; Tahiti
Micronesia: Commonwealth of the Northern Marianas Islands; Republic of Palau; Federated
States of Micronesia; Nauru; Republic of the Marshall Islands Melanesia: Vanuatu; Solomon
Islands; New Caledonia; Fiji; New Guinea

II. Minimum Inventory Requirement (MIR) and Minimum Sales Responsibility (MSR):

PRODUCT LINE (S)	MIR*	MSR*
Berkshire Coach, Champion, Eldorado National (KS), Elkhart Coach, Federal Coach, Krystal, Starcraft Bus, StarTrans Bus	10	120

*MIR and MSR are stated in units. MIR must be maintained on a continuous basis. Units qualifying toward the MIR are new and unsold units which dealer has in stock or on order for immediate delivery.

Dealer Signature: *Denise A. Soderholm*

Dealer Title: Pres.

Date: 9-8-20

Accepted: Forest River Bus, a division of Forest River, Inc.

[Signature]
Forest River Bus President



631 W. 11th Street
P.O. Box 310
Winamac, IN 46996
1-800-THE-LIFT
(574) 946-6153
Fax (574) 946-4670

www.braunability.com

September 10, 2019

R. Erik Soderholm
Vice President
Soderholm Sales and Leasing, Inc.
2044 Dillingham Blvd.
P.O. Box 19010
Honolulu, HI 96817

To Who it May Concern:

This letter is to confirm that **Soderholm Sales and Leasing, Inc.** is in good standing with BraunAbility and is currently the only authorized Commercial Service Center for BraunAbility Commercial products in the State of Hawaii. Furthermore, **Soderholm Sales and Leasing, Inc.** represents Braun Commercial product in Guam, Saipan, American Samoa and the Commonwealth of the Northern Mariana Islands (CNMI).

Should you require any additional information, please feel free to contact us at 800-843-5438.

Sincerely,

Colton M Walle

Area Sales Manager – Southwest
BraunAbility



American Cooling Technology, Inc.
715 Willow Springs Lane York, PA. 17406
Tel: (717) 767-2775 Fax: (717) 767-3658
www.actusa.us.com

9/15/19

Erik Soderholm, President
Soderholm Sales and Leasing
2044 Dillingham Blvd
Honolulu, HI 96819

RE Authorized Warranty, Service and Parts Center

Erik

Soderholm Sales and Leasing is the sole authorized Warranty, Service and Parts location for American Colling Technology, Inc. – ProAir LLC for the State of Hawaii including Guam, Commonwealth of the Marianas Islands, American Samoa, Federated States of Micronesia, Marshall Islands and Palau.

Please feel free to contact us with any questions

Regards

Gary Treharne
National Director of Sales BUS
American Cooling Technology, Inc.
491 Westberry Lane
Greenwood, IN 46142
garyt@actusa.us.com
www.actusa.us.com



September 12, 2019

Erik Soderholm
Soderholm Sales and Leasing
2044 Dillingham Blvd.
Honolulu, HI 96817

Dear Erik,

First, I want to thank you for 30+ years of business, support, loyalty and friendship. We truly appreciate everything you and Soderholm Sales and Leasing (SSL) do for Freedman Seating. In response to your request, I am pleased to provide the following.

Freedman Seating is happy to recognize SSL as its's exclusive premier dealer for service, parts and warranty center for the Pacific Islands including Hawaii, Guam, Commonwealth of the Marianas Islands, American Samoa, Federated States of Micronesia, Marshall Islands & Palau.

Again, thank you for all your help and support.

Sincerely,

A handwritten signature in black ink, appearing to read "Dan Cohen", written over a white background.

Dan Cohen
President
Freedman Seating

EXHIBIT M1

REVISIONS			
ECN No.	REV LVL.	DATE	ZONE INITIAL

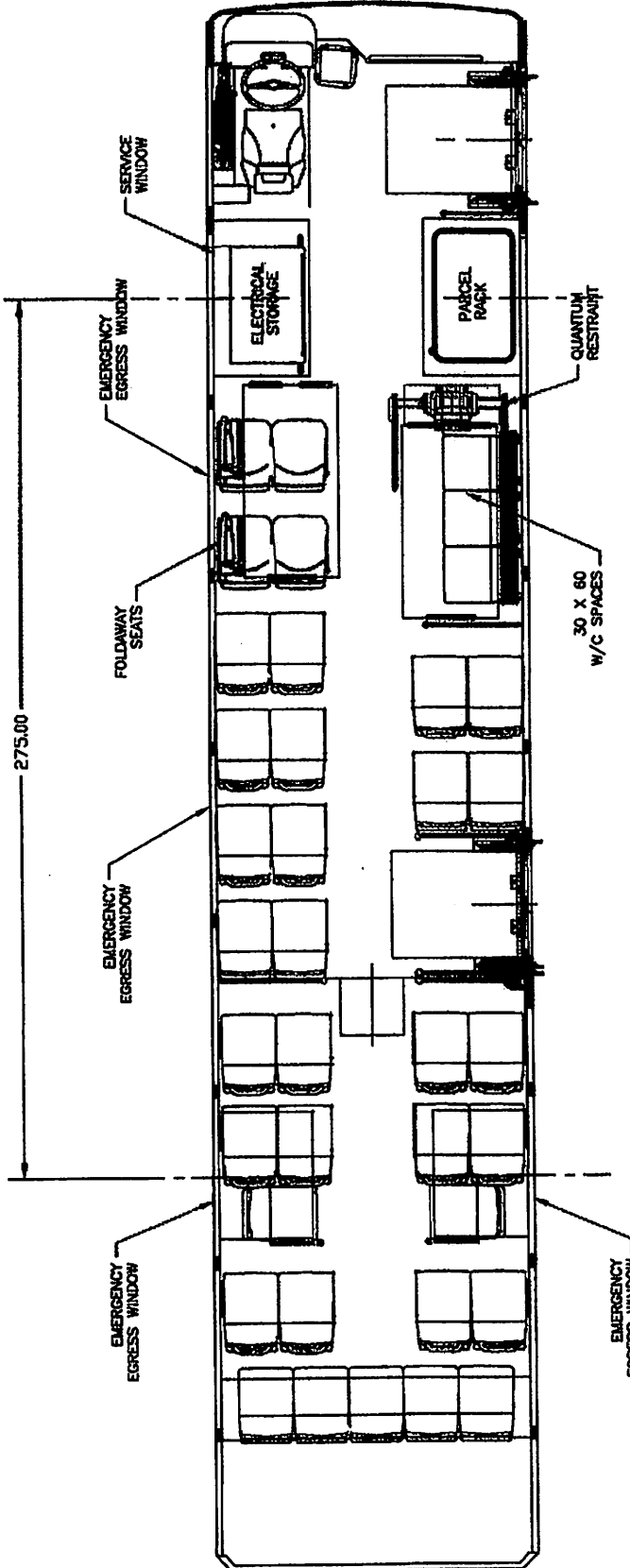

R. Quinn 18/24/18

CONCEPTUAL PROPOSAL ONLY
CAPACITY:

- 31 PASSENGERS WITH 2 WHEEL CHAIR POSITIONS
- OR
- 38 PASSENGERS PLUS DRIVER
- FREEDMAN CITISEATS

R3

	DATE: 10/12/18 DRAWN BY: LOREN L. 3792/18 APPROVED:	TITLE: FLOOR PLAN ACCESS - 40' HD	SHEET: 1 OF 1
SCALE: 1/4" = 1'-0" NUMBER OF SHEETS: 1 TOTAL SHEETS: 1	PROJECT NO.: 892F10C0003	ADDRESS: 8970 Galena Street, Riverside, CA 92509 PHONE: (951) 591-9257	SHEET: 1 OF 1

NOTES: UNLESS OTHERWISE SPECIFIED, THIS DRAWING IS DESIGN & DETAIL IS THE PROPERTY OF FLOORPLAN INTERNATIONAL & MUST NOT BE USED EXCEPT IN CONNECTION WITH OUR WORK. ALL RIGHTS OF DESIGN OR INVENTION ARE RESERVED.

EXHIBIT M2

REVISIONS				
ECN No.	REV LVL	DESCRIPTION	DATE	ZONE INITIAL

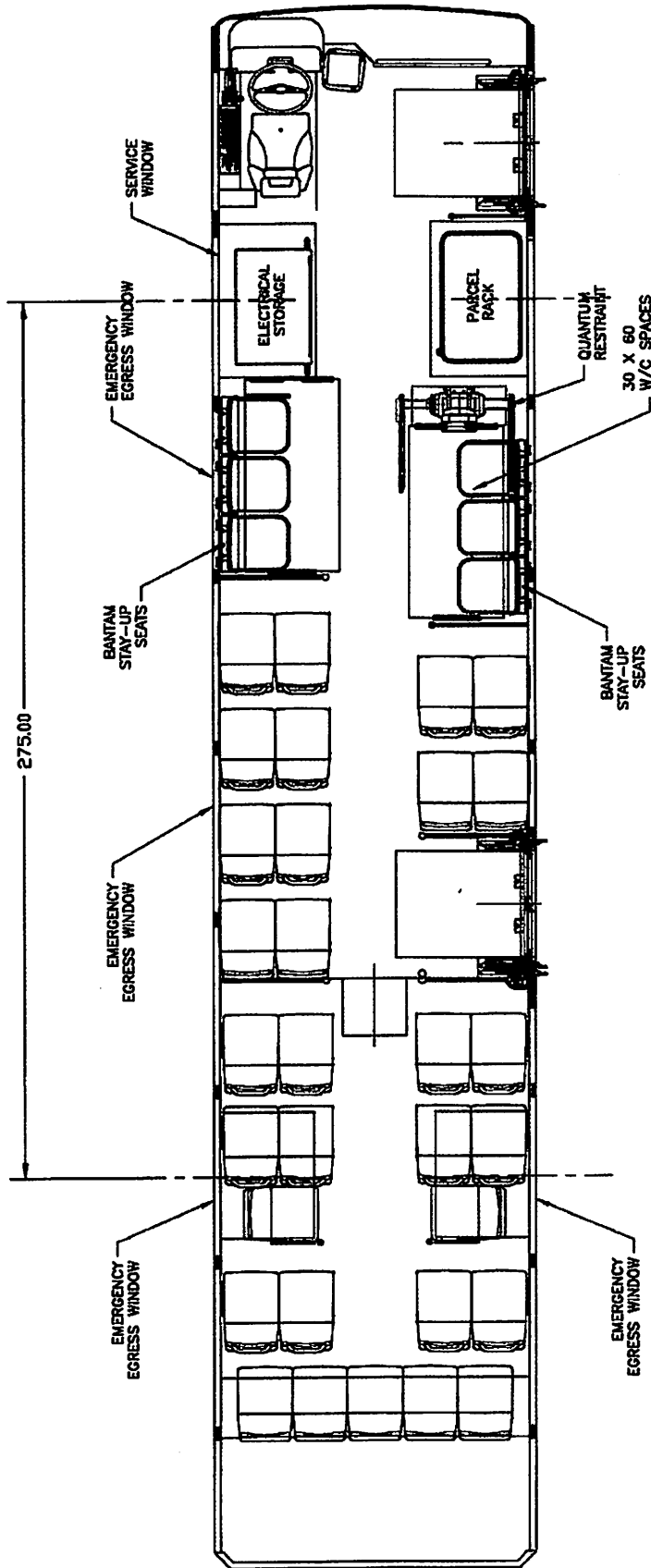

CONCEPTUAL PROPOSAL ONLY

CAPACITY:

- 31 PASSENGERS WITH 2 WHEEL CHAIR POSITIONS
- OR
- 37 PASSENGERS PLUS DRIVER
- FREEDMAN CITISEATS

NOTES: UNLESS OTHERWISE SPECIFIED. THIS DRAWING IN DESIGN & DETAIL IS THE PROPERTY OF BLOORSCO MIDWAY & MUST NOT BE USED EXCEPT IN CONNECTION WITH OUR WORK. ALL RIGHTS OF DESIGN OR INVENTION ARE RESERVED.

R3



DESIGNED BY LOREN L. 11/8/18	DATE 11/8/18	SCALE 1"=4'	SIZE A
APPROVED			
TITLE FLOOR PLAN AVSS - 40' HD			
9870 Galena Street Riverside, CA 92509 Phone (909) 591-0657		DWG NO. 892F10030016	SHEET 1 OF 1

COUNTY OF KAUAI
IFB #3677

EXHIBIT N1

C

- NOTES:
1. E-EGRESS WINDOW LOCATIONS
 2. FA - FIRST AID KIT
 3. FE - FIRE EXTINGUISHER
 4. T- TRIANGLE KIT
 5. MID BACK SINGLE SEAT
 6. DOUBLE BV FOLDAWAY SEAT W/O NOTCH

7. RETRACTABLE SEATBELTS
8. V- MID/LOW BACK SEAT GRAB HANDLE
9. FLEX GUARD DOUBLE FOLDAWAY
10. CAMERA LOCATIONS

TELMA RETARDER
SUMD SPRING SUSPENSION KIT
ALTRD FLOORING STORM GREY
FRP INTERIOR WALLS GREY
FRP CEILING GREY

REV	DATE	BY	CHK	DESCRIPTION	DRAWING TITLE BLOCK
A	3/9/2020	C0413	MNF	DRIVER VALVE BACK AREA FLECT BOX	
B	3/27/2020		MNF	CHANGED TO HORIZONTAL TRACK	

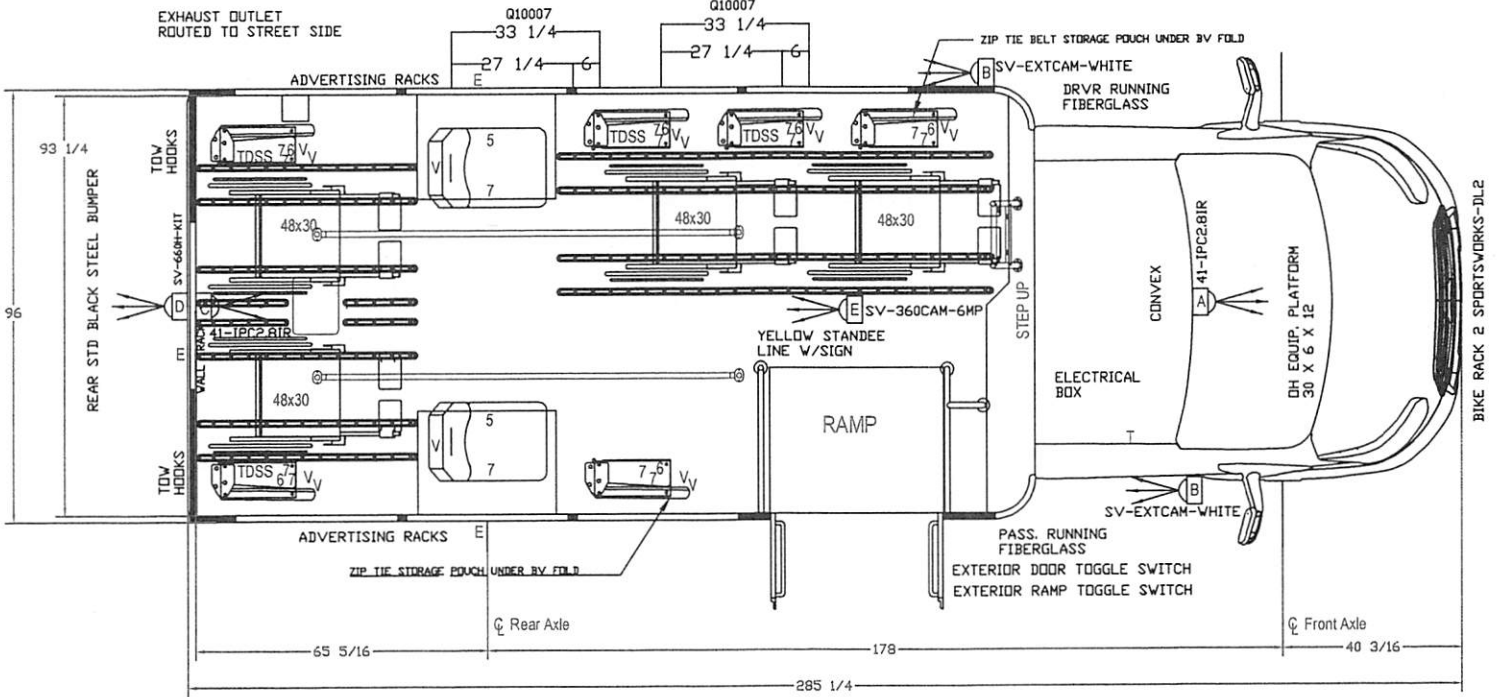

ARBOC Specialty Vehicles

ARBOC SPECIALTY VEHICLES CLAIMS PROPRIETARY RIGHTS IN THE MATERIAL DISCLOSED HEREON. NEITHER THIS DRAWING NOR ANY REPRODUCTION THERE OF MAY BE USED TO MANUFACTURE ANYTHING SHOWN HEREON WITHOUT PERMISSION IN WRITING FROM ARBOC SPECIALTY VEHICLES TO THE USER SPECIFICALLY REFERRING TO THE DRAWINGS. INFORMATION CONTAINED HEREON MAY BE THE EXPRESS PROPERTY OF ARBOC SPECIALTY VEHICLES AND PROTECTED IN THE FORM OF A U.S. PATENT.

TOLERANCES:
FLOOR PLAN DIMS ± 1/8"
FRACTIONAL DIMS ± 1/16"
2 PLACE DECIMAL DIMS ± .01"
3 PLACE DECIMAL DIMS ± .005"

NAME:		FLOOR PLAN, 14PS-4WC-178G-S0123		
DRAWN BY:	DATE:	DRAWING NUMBER:	REVISION:	SHEET:
MNF	2/20/2020	1206512-MNF COUNTY OF KAUAI		1 OF 2

R Qui... 4/3/20

COUNTY OF KAUAI
IFB #3677

EXHIBIT N2

NOTES:

1. E-EGRESS WINDOW LOCATIONS
2. FA - FIRST AID KIT
3. FE - FIRE EXTINGUISHER
4. T- TRIANGLE KIT
5. MID BACK SINGLE SEAT
6. DOUBLE BV FOLDAWAY SEAT W/O NOTCH

7. RETRACTABLE SEATBELTS
8. V- MID/LOW BACK SEAT GRAB HANDLE
9. FLEX GUARD DOUBLE FOLDAWAY
10. CAMERA LOCATIONS

TELMA RETARDER
SUMO SPRING SUSPENSION KIT
ALTRD FLOORING STORM GREY
FRP INTERIOR WALLS GREY
FRP CEILING GREY

REV	DATE	BY	CHK	APP	DESCRIPTION	DRAWING TITLE & NO.
A	3/9/2020	MNF	CD413		REMOVED WALKER BACK ADDED ELECT BOX	
B	3/27/2020	MNF			CHANGED TO HORIZONTAL TRACK	
C	7/20/2020	MNF			REAR RV'S TO BE SINGLES	
D	7/24/2020	MNF			DELETE FRONT BV MAKE REARS DOUBLES	
E	8/4/2020	MNF			SHOP LOOSE PS FRONT BV FOLD	
F	8/5/2020	MNF			C/S BY FOLD BACK IN BUS	

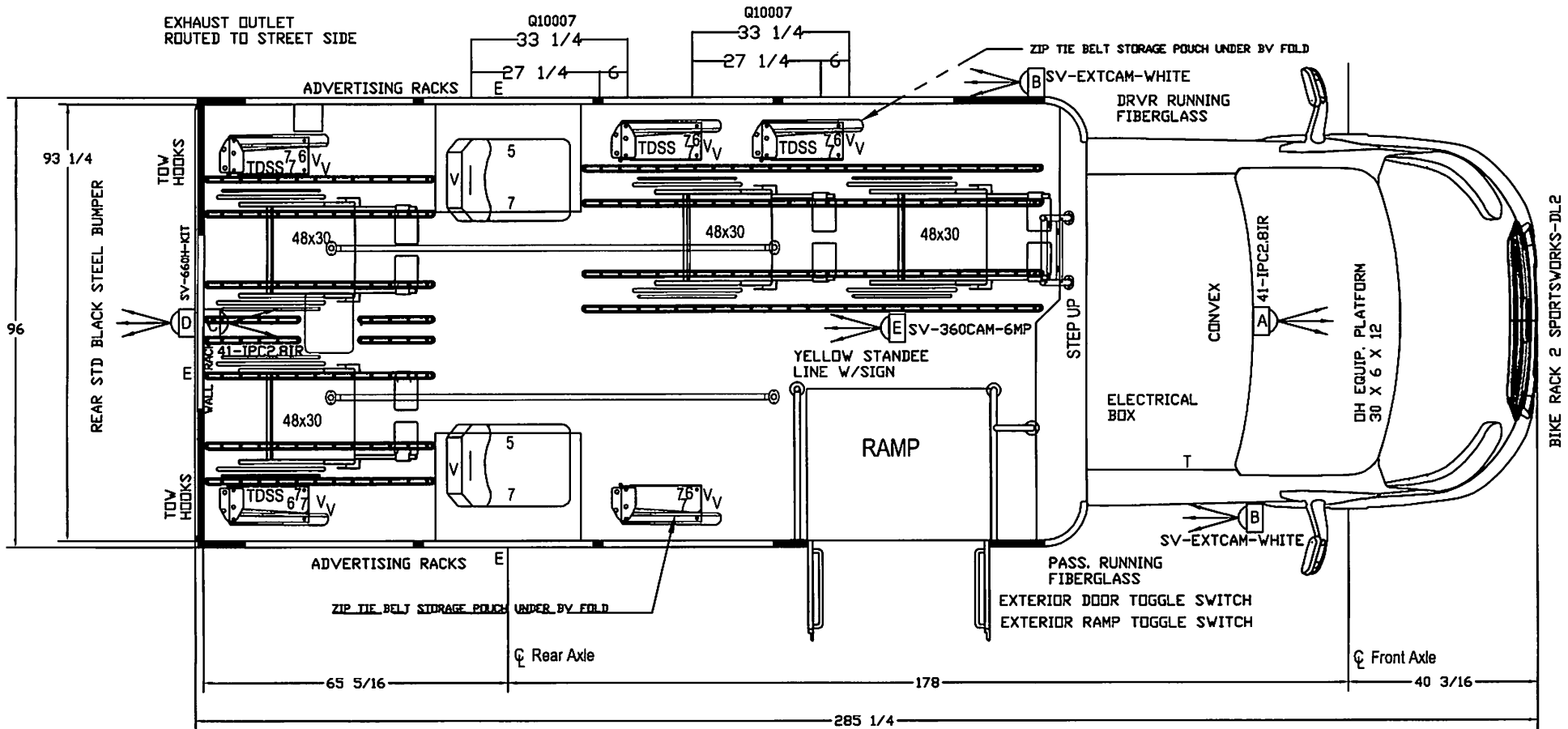

ARBOC SPECIALTY VEHICLES CLAIMS PROPRIETARY RIGHTS IN THE MATERIAL DISCLOSED HEREON. NEITHER THIS DRAWING NOR ANY REPRODUCTION THERE OF MAY BE USED TO MANUFACTURE ANYTHING SHOWN HEREON WITHOUT PERMISSION IN WRITING FROM ARBOC SPECIALTY VEHICLES TO THE USER SPECIFICALLY REFERRING TO THE DRAWINGS. INFORMATION CONTAINED HEREON MAY BE THE EXPRESS PROPERTY OF ARBOC SPECIALTY VEHICLES AND PROTECTED IN THE FORM OF A U.S. PATENT.

TOLERANCES:
FLOOR PLAN DIMS: ± 1/8"
FRACTIONAL DIMS: ± 1/16"
2 PLACE DECIMAL DIMS: ± .01"
3 PLACE DECIMAL DIMS: ± .005"

NAME:
FLOOR PLAN, 12PS-4VC-178G-S0123

DRAWN BY:	DATE:	DRAWING NUMBER:	REVISION:	SHEET:
MNF	2/20/2020	1206512-MNF COUNTY OF KAUAI	F	1 OF 2

Erik Soderholm

From: Erik Soderholm
Sent: Wednesday, August 05, 2020 3:21 PM
To: 'Tellis, Ray (FTA)'
Cc: 'Claudia Acfalle'; 'Anita Cruz'; 'Robert Kono'; 'Christine Tedtaotao'; 'Celestin Babauta'; 'Rally M. Pilipina'; 'Catherine Blas'; Denise Soderholm; Gus Soderholm; Jessica Scheuring; 'dhendrixson@forestriverinc.com'; 'rryff@forestriverinc.com'; 'Charlie Reynolds'; 'Jeffrey Miller'; 'Fujii, Ryan (FTA)'
Subject: RE: GSA-055-19 Buy America appeal

Ray: OK. Thank you.

We agree that Buy America compliance is matter of primarily of Federal concern. We would say today though it is an matter of preeminent Federal concern with the pandemic exposing the lack of U.S. made products & parts stream which has hampered the U.S. national transportation system.

We understand that the FTA is now investigating this appeal from us to the GRTA & GSA in Guam but we would like to be kept informed? It was our appeal to the FTA for this breach of Buy America that started this process. We are an interested party.

Thank you for your review.

R. Erik Soderholm
Vice President
Soderholm Sales & Leasing, Inc.
2044 Dillingham Blvd. Honolulu, HI 96819 Mailing address: P.O. Box 19010 Honolulu, HI 96817
808-834-1417 Fax 808-834-1070
erik@soderholmbus.com www.soderholmbus.com

This message and any attachments contain confidential information and is the property of Soderholm Sales and Leasing, Inc. and/or Soderholm Mobility, Inc.. If you are not the intended recipient (or authorized to receive for the recipient) and received this message in error; any use, distribution or disclosure is strictly prohibited. Please contact the sender by reply e-mail and delete all copies of this message from your computer system.

-----Original Message-----

From: Tellis, Ray (FTA) [mailto:Ray.Tellis@dot.gov]
Sent: Wednesday, August 05, 2020 3:03 PM
To: Erik Soderholm <erik@soderholmbus.com>
Cc: Claudia Acfalle <Claudia.Acfalle@gsadoa.guam.gov>; Anita Cruz <Anita.Cruz@gsadoa.guam.gov>; Robert Kono <robert.kono@gsa.guam.gov>; Christine Tedtaotao <Christine.Tedtaotao@gsadoa.guam.gov>; Celestin Babauta <celestin.babauta@grta.guam.gov>; Rally M. Pilipina <rally.pilipina@grta.guam.gov>; Catherine Blas <catherine.blas@grta.guam.gov>; Denise Soderholm <denise@soderholmbus.com>; Gus Soderholm <gus@soderholmbus.com>; Jessica Scheuring <jessica@soderholmbus.com>; dhendrixson@forestriverinc.com; rryff@forestriverinc.com; Charlie Reynolds <charlie.reynolds@triplejhq.com>; Jeffrey Miller <jeff@millershealaw.com>; Fujii, Ryan (FTA) <ryan.fujii@dot.gov>

Subject: RE: GSA-055-19 Buy America appeal
Importance: High

Erik:

We acknowledge receipt of your bid protest appeal dated June 26, 2020. Generally, FTA will not substitute its judgment for the Grantee's judgment in procurement decisions. The Uniform Guidance, as adopted by DOT, no longer includes the language in 49 CFR § 18.36(b)(12) that provides for a direct appeal to FTA of a recipient's final decision on a bid protest.

Specifically, the Uniform Guidance states: "The non-Federal entity alone must be responsible, in accordance with good administrative practice and sound business judgment, for the settlement of all contractual and administrative issues arising out of procurements. These issues include, but are not limited to, source evaluation, protests, disputes, and claims. These standards do not relieve the non-Federal entity of any contractual responsibilities under its contracts. The Federal awarding agency will not substitute its judgment for that of the non-Federal entity unless the matter is primarily a Federal concern. Violations of law will be referred to the local, state, or Federal authority having proper jurisdiction." 2 CFR § 200.318(k). Accordingly, FTA's role is limited to considering matters that are "primarily a Federal concern."

Since Buy America is a matter primarily of a Federal concern, FTA is consulting with Guam Regional Transit Authority (RTA) to review procurement documentation to determine whether the Guam GSA procurement is in compliance with FTA Buy America requirements. If the procurement is not in compliance, then it would not be eligible for federal funds. FTA will work directly with Guam as part of its oversight role to ensure Buy America compliance.

Thank you.

Ray

-----Original Message-----

From: Fujii, Ryan (FTA)

Sent: Tuesday, August 4, 2020 10:21 AM

To: Erik Soderholm <erik@soderholmbus.com>

Cc: Tellis, Ray (FTA) <Ray.Tellis@dot.gov>; Claudia Acfalle <Claudia.Acfalle@gsadoa.guam.gov>; Anita Cruz <Anita.Cruz@gsadoa.guam.gov>; Robert Kono <robert.kono@gsa.guam.gov>; Christine Tedtaotao <Christine.Tedtaotao@gsadoa.guam.gov>; Celestin Babauta <celestin.babauta@grta.guam.gov>; Rally M. Pilipina <rally.pilipina@grta.guam.gov>; Catherine Blas <catherine.blas@grta.guam.gov>; Denise Soderholm <denise@soderholmbus.com>; Gus Soderholm <gus@soderholmbus.com>; Jessica Scheuring <jessica@soderholmbus.com>; dhendrixson@forestriverinc.com; rryff@forestriverinc.com; Charlie Reynolds <charlie.reynolds@triplejhq.com>; Jeffrey Miller <jeff@millershealaw.com>

Subject: RE: GSA-055-19 Buy America appeal

Good Morning Mr. Soderholm,

We will provide a response as soon as we are able to complete our review.

Thank you,

Ryan Fujii
General Engineer
U.S. Department of Transportation

Federal Transit Administration, Region 9
300 Ala Moana Blvd., Room 3-306
Honolulu, Hawaii 96850
Email: ryan.fujii@dot.gov
Phone: (202) 748 - 0677

-----Original Message-----

From: Erik Soderholm [mailto:erik@soderholmbus.com]
Sent: Tuesday, August 4, 2020 6:08 AM
To: Fujii, Ryan (FTA) <ryan.fujii@dot.gov>
Cc: Tellis, Ray (FTA) <Ray.Tellis@dot.gov>; Claudia Acfalle <Claudia.Acfalle@gsadoa.guam.gov>; Anita Cruz <Anita.Cruz@gsadoa.guam.gov>; Robert Kono <robert.kono@gsa.guam.gov>; Christine Tedtaotao <Christine.Tedtaotao@gsadoa.guam.gov>; Celestin Babauta <celestin.babauta@grta.guam.gov>; Rally M. Pilipina <rally.pilipina@grta.guam.gov>; Catherine Blas <catherine.blas@grta.guam.gov>; Denise Soderholm <denise@soderholmbus.com>; Gus Soderholm <gus@soderholmbus.com>; Jessica Scheuring <jessica@soderholmbus.com>; dhendrixson@forestriverinc.com; rryff@forestriverinc.com; Charlie Reynolds <charlie.reynolds@triplejhq.com>; Jeffrey Miller <jeff@millershealaw.com>
Subject: Re: GSA-055-19 Buy America appeal

CAUTION: This email originated from outside of the Department of Transportation (DOT). Do not click on links or open attachments unless you recognize the sender and know the content is safe.

Ryan: OK. Thank you for responding.

How long will it take the FTA to respond to the issue - a few months more?

Aloha,
R. Erik Soderholm

Sent from my iPhone

> On Aug 3, 2020, at 8:02 PM, Fujii, Ryan (FTA) <ryan.fujii@dot.gov> wrote:
>
> Good evening Mr. Soderholm,
>
> We are in receipt of your Buy America Appeal and it is currently under review. We will respond to you in the near future.
>
> Thank you,
>
> Ryan Fujii
> General Engineer
> U.S. Department of Transportation
> Federal Transit Administration, Region 9
> 300 Ala Moana Blvd., Room 3-306
> Honolulu, Hawaii 96850
> Email: ryan.fujii@dot.gov
> Phone: (202) 748 - 0677
>
> -----Original Message-----

> From: Erik Soderholm [mailto:erik@soderholmbus.com]
> Sent: Monday, August 3, 2020 5:48 PM
> To: Tellis, Ray (FTA) <Ray.Tellis@dot.gov>
> Cc: Fujii, Ryan (FTA) <ryan.fujii@dot.gov>; Claudia Acfalle
> <Claudia.Acfalle@gsadoa.guam.gov>; Anita Cruz
> <Anita.Cruz@gsadoa.guam.gov>; Robert Kono <robert.kono@gsa.guam.gov>;
> Christine Tedaotao <christine.tedaotao@gsadoa.guam.gov>; Celestin
> Babauta <celestin.babauta@grta.guam.gov>; Rally M. Pilipina
> <rally.pilipina@grta.guam.gov>; Catherine Blas
> <catherine.blas@grta.guam.gov>; Denise Soderholm
> <denise@soderholmbus.com>; Gus Soderholm <gus@soderholmbus.com>;
> Jessica Scheuring <jessica@soderholmbus.com>;
> dhendrixson@forestriverinc.com; rryff@forestriverinc.com; Charlie
> Reynolds <charlie.reynolds@triplejhq.com>; Jeffrey Miller
> <jeff@millershealaw.com>
> Subject: RE: GSA-055-19 Buy America appeal

> CAUTION: This email originated from outside of the Department of Transportation (DOT). Do not click on links or open attachments unless you recognize the sender and know the content is safe.

> Ray: Would you please confirm receipt of the Buy America appeal we sent in on 6/26/20? And the status?

> Thank you.

> R. Erik Soderholm

> Vice President

> Soderholm Sales & Leasing, Inc.

> 2044 Dillingham Blvd. Honolulu, HI 96819 Mailing address: P.O. Box 19010 Honolulu, HI 96817

> 808-834-1417 Fax 808-834-1070

> erik@soderholmbus.com

> <https://gcc01.safelinks.protection.outlook.com/?url=http%3A%2F%2Fwww.soderholmbus.com%2F&data=02%7C01%7CRay.Tellis%40dot.gov%7C6b953f2405e04f37e24608d8389ac3e8%7Cc4cd245b44f04395a1aa3848d258f78b%7C0%7C0%7C637321584649542212&sdata=xggx3qTMIVvqMs%2BCY%2FRs5hXx1TdJbQMze2ZZBYo3vr0%3D&reserved=0>

> This message and any attachments contain confidential information and is the property of Soderholm Sales and Leasing, Inc. and/or Soderholm Mobility, Inc.. If you are not the intended recipient (or authorized to receive for the recipient) and received this message in error; any use, distribution or disclosure is strictly prohibited. Please contact the sender by reply e-mail and delete all copies of this message from your computer system.

> -----Original Message-----

> From: Erik Soderholm [mailto:erik@soderholmbus.com]

> Sent: Friday, June 26, 2020 3:46 PM

> To: 'Ray.Tellis@dot.gov' <Ray.Tellis@dot.gov>

> Cc: 'Fujii, Ryan (FTA)' <ryan.fujii@dot.gov>; 'Claudia Acfalle'

> <Claudia.Acfalle@gsadoa.guam.gov>; 'Anita Cruz'

> <Anita.Cruz@gsadoa.guam.gov>; 'Robert Kono' <robert.kono@gsa.guam.gov>; 'Christine Tedtaotao' <christine.tedtaotao@gsadoa.guam.gov>; 'Celestin Babauta' <celestin.babauta@grta.guam.gov>; 'Rally M. Pilipina'

> <rally.pilipina@grta.guam.gov>; 'Catherine Blas'

> <catherine.blas@grta.guam.gov>; 'Denise Soderholm'

> <denise@soderholmbus.com>; Gus Soderholm <gus@soderholmbus.com>; Jessica Scheuring <jessica@soderholmbus.com>; 'dhendrixson@forestriverinc.com'

> <dhendrixson@forestriverinc.com>; 'rryff@forestriverinc.com'

> <rryff@forestriverinc.com>; 'Charlie Reynolds'

> <charlie.reynolds@triplejhq.com>; 'Jeffrey Miller'

> <jeff@millershealaw.com>

> Subject: FW: GSA-055-19 Buy America appeal

>

> Ray Tellis

> Regional Administrator

> Federal Transit Administration

>

> Ray: At the direction of Ryan Fujii, at the FTA regional office in

> Honolulu, we are directing our protest to the Pre-Award BUY AMERICA

> CERTIFICATION for the Territory of Guam GSA-055-19 bid to you based on

> the

> following:

>

> 1) Please find attached a copy of the denial of our protest by Claudia Acfalle, Chief Procurement Officer, Department of Admiration, General Services Agency (GSA), Territory of Guam for your review.

> Please note we were the low bidder by \$4,474.20 per bus for the 10 bus bid. Claudia also noted that "Out bid was the lowest responsive and responsible bid. GSA response: Agree..."? There can't be a caveat when you are the lowest responsive and responsible bidder.

>

> 2) Per the requirements of the FTA Buy America certification protest (1)(a), Soderholm Sales and Leasing, Inc. (SSL) we are an interested party. SSL was a bidder as evidenced by the by the attached Abstract of IFB. Please note the Abstract identifies SSL as Soderholm Bus & Mobility which is a legal DBA but out bid was submitted in SSL's legal name, Soderholm Sales and Leasing, Inc.

>

> 3) Per (1)(b) we have exhausted our administrative remedies, per the denial of our protest attached.

>

> 4) Per (1)(c) this protest of the Buy America certification is timely as its within five (5) days - 6/22/20 to 6/26/20 which we should actually have until 6/29/20.

>

> 5) Our appeal of the Buy America certification is based on the following:

>

> - Please see attached a copy of the signed Pre-Award BUY AMERICA CERTIFICATION by Scott Defrees of StarCraft Bus/Forest River Inc. dated 2/17/20.

>

> - The IFB bid opened 11/15/19.

>

> - The other bidder, Monster Auto Spot, the GMC dealer in Guam, did not submit a BUY AMERICA CERTIFICATION in their bid.

>

> - They submitted the attached BUY AMERICA CERTIFICATION nearly 4 months later to try to make up for lack of responsiveness & responsibility. You can't add left out required items to an IFB bid after the fact. That is

patently unfair. GSA has bent over backwards to award this bid to Monster Auto Spot due to the close political and employment relationship of the Lieutenant Governor of Guam and the Monster Auto Spot.

- >
- > - SSL submitted our Buy America Certification with our bid on 11/15/19.
- >
- > - Please find attached a letter dated 1/24/19 from Forest River, Inc., the parent company of StarCraft Bus, the bus manufacturer Monster Auto Spot bid. It clearly states that, "After this March 1, 2019 deadline, GM chassis will not be considered on FTA-funded vehicle purchases due to the new 70% domestic content requirement.
- >
- > - The Monster Auto Spot - BUY AMERICA CERTIFICATION is also defective since it has a 4.55% in unaccounted costs? In all my 30+ years of hundreds of bids and review of hundreds of Buy America certifications, I nor any industry veteran we know, have ever seen a Buy America certificate with an unaccounted cost? Moreover the 4.55% is within the margin of error of the 73.49% to go below the 70% requirement. Additionally the total now amounts to 104.55% which is absurd.
- >
- > - GSA also got the director of the transit agency, Guam Regional Transit Agency (GRTA), Cel Babauta, to certify the Buy America Certificate! That is ridiculous. I have never seen that. Cel has no authority or knowledge to certify a bus built at StarCraft/Forest River. Moreover he a political appointee of the Governor.
- >
- > - This is a clear sham to certify the Buy America Certificate after the fact.
- >
- > - No U.S. bus builder can meet the 70% Buy America limit now using a GM/GMC chassis. See attached our similar letter from our bus manufacturer, ElDorado, that states dealers can't use GM/GMC chassis for FTA funded procurements. That is why we bid a Ford chassis that meets Buy America.
- >
- > Ray, we request the FTA deny the GSA attempt to fund this purchase
- > based on the defective BUY AMERICA CERTIFICATION by Monster Auto Spot.
- > This will cause the GSA to rebid the bid, and Monster Auto Spot will
- > have to produce a real Buy America Certificate if they can? We know
- > Buy America is dear to the FTA's mission, and under the current
- > environment that during the
- > COVID-19 pandemic where the U.S. can't even get the essential PPE supplies in the U.S., that the administration would not tolerate the Territory of Guam from buying outside if the U.S. with U.S. FTA funds.
- >
- > We thank you for your review, and your decision? Please call or email us any questions?
- >
- > Sincerely,
- >
- > R. Erik Soderholm, Esq.
- > Vice President
- > Soderholm Sales & Leasing, Inc.
- > 2044 Dillingham Blvd. Honolulu, HI 96819 Mailing address: P.O. Box
- > 19010 Honolulu, HI 96817
- > 808-834-1417 Fax 808-834-1070
- > erik@soderholmbus.com
- > <https://gcc01.safelinks.protection.outlook.com/?url=http%3A%2F%2Fwww.soderholmbus.com%2F&data=02%7C01%7CRay.Tellis%40dot.gov%7C6b953f2405e04f37e24608d8389ac3e8%7Cc4cd245b44f04395a1aa3848d258f78b%7C0%7C0%7C637321584649542212&data=xggx3qTMIVvqMs%2BCY%2FRs5hXx1TdJbQMze2ZZBYo3vr0%3D&reserved=0>
- >
- >

> This message and any attachments contain confidential information and is the property of Soderholm Sales and Leasing, Inc. and/or Soderholm Mobility, Inc.. If you are not the intended recipient (or authorized to receive for the recipient) and received this message in error; any use, distribution or disclosure is strictly prohibited. Please contact the sender by reply e-mail and delete all copies of this message from your computer system.

>

>

>

> -----Original Message-----

> From: gsaprocurment [mailto:gsaprocurment@gsadoa.guam.gov]

> Sent: Tuesday, June 23, 2020 3:09 PM

> To: Erik Soderholm <erik@soderholmbus.com>

> Cc: Claudia Acfalle <Claudia.Acfalle@gsadoa.guam.gov>; Anita Cruz

> <Anita.Cruz@gsadoa.guam.gov>; Robert Kono <robert.kono@gsa.guam.gov>

> Subject: GSA-055-19 Response

>

> Hafa adai,

>

> Please see the following attachment in regards to GSA bid GSA-055-19 and kindly acknowledge upon receipt of this email and forward back via:

> gsaprocurment@gsadoa.guam.gov.

> Your immediate response is greatly appreciated.

>

> Thank you,

>

> GSA Procurement

> General Services Agency

> GovGuam

> (671) 475-1707

Erik Soderholm

From: Jerrick Hernandez <jhernandez@guamopa.com> on behalf of Jerrick Hernandez
Sent: Monday, August 03, 2020 12:58 PM
To: Denise Soderholm
Cc: Erik Soderholm; Gus Soderholm; Jessica Scheuring; fleetsales@triplejguam.com; Clariza Roque; Matthew E. Wolff; Robert Kono
Subject: Re: OPA-PA-20-006 Pre-Hearing Conference

This is noted. Thank you.

On Tue, Aug 4, 2020, 8:52 AM Denise Soderholm <denise@soderholmbus.com> wrote:

Jerrick,

If 2 people are allowed to speak on our behalf, please also list my name, Denise L. Soderholm, Pres.

Erik will be speaking primarily, but I would like to be allowed, should I have something to add.

Thank you,

Denise L. Soderholm

President

Soderholm Sales and Leasing, Inc.

PO Box 19010

Honolulu, HI 96817

Ph: (808) 834-1417

Fax: (808) 834-1070

www.soderholmbus.com

President

Soderholm Mobility, Inc.

2044 Dillingham Blvd.

Honolulu, HI 96819

This message and any attachments contain confidential information and is the property of Soderholm Sales and Leasing, Inc. and/or Soderholm Mobility, Inc.. If you are not the intended recipient (or authorized to receive for the recipient) and received this message in error; any use, distribution or disclosure is strictly prohibited. Please contact the sender by reply e-mail and delete all copies of this message from your computer system.

From: Erik Soderholm [mailto:erik@soderholmbus.com]

Sent: Monday, August 03, 2020 12:07 PM

To: Jerrick Hernandez <jhernandez@guamopa.com>; Gus Soderholm <gus@soderholmbus.com>

Cc: Denise Soderholm <denise@soderholmbus.com>; Jessica Scheuring <jessica@soderholmbus.com>; fleetsales@triplejguam.com; Clariza Roque <croque@guamopa.com>; Matthew E. Wolff <mwolff@oagguam.org>; Robert Kono <robert.kono@gsa.guam.gov>

Subject: RE: OPA-PA-20-006 Pre-Hearing Conference

Jerrick: OK. I will. R. Erik Soderholm, VP.

Thank you.

R. Erik Soderholm

Vice President

Soderholm Sales & Leasing, Inc.

2044 Dillingham Blvd. Honolulu, HI 96819

Mailing address: P.O. Box 19010 Honolulu, HI 96817

808-834-1417 Fax 808-834-1070

erik@soderholmbus.com

www.soderholmbus.com

This message and any attachments contain confidential information and is the property of Soderholm Sales and Leasing, Inc. and/or Soderholm Mobility, Inc.. If you are not the intended recipient (or authorized to receive for the recipient) and received this message in error; any use, distribution or disclosure is strictly prohibited. Please contact the sender by reply e-mail and delete all copies of this message from your computer system.

From: Jerrick Hernandez [mailto:jhernandez@guamopa.com]
Sent: Monday, August 03, 2020 11:43 AM
To: Gus Soderholm <gus@soderholmbus.com>; Erik Soderholm <erik@soderholmbus.com>
Cc: Denise Soderholm <denise@soderholmbus.com>; Jessica Scheuring <jessica@soderholmbus.com>;
fleetsales@triplejguam.com; Clariza Roque <croque@guamopa.com>; Matthew E. Wolff <mwolff@oagguam.org>;
Robert Kono <robert.kono@gsa.guam.gov>
Subject: Re: OPA-PA-20-006 Pre-Hearing Conference

Hafa Adai,

We don't mind you all attending the Pre-Hearing Conference held via Zoom Meeting today, but we need confirmation on who will be speaking on behalf of the Appellant. Typically there's an Attorney and an Institutional Representative who would appear on behalf of the party. All others will be muted during the Zoom Meeting to ensure there is no unnecessary interruptions and to preserve the audio recording of the hearing conference.

Please let us know who will be speaking on behalf of Soderholm Sales and Leasing, Inc. In lieu of an Attorney, we will allow up to two Institutional Representatives. Thank you.

On Tue, Aug 4, 2020, 6:32 AM Gus Soderholm <gus@soderholmbus.com> wrote:

Folks: Just registered.

Keep in mind this is 6 pm today (Monday August 3rd) in Hawaii.

Gus Soderholm

Sales Consultant

Soderholm Sales and Leasing, Inc.

PO Box 19010

Honolulu, HI 96817

Ph: (808) 834-1417

Soderholm Mobility, Inc.

2044 Dillingham Blvd.

Honolulu, HI 96819

Fax: (808) 834-1070

www.soderholmbus.com

This message and any attachments contain confidential information and is the property of Soderholm Sales and Leasing, Inc. and/or Soderholm Mobility, Inc.. If you are not the intended recipient (or authorized to receive for the recipient) and received this message in error; any use, distribution or disclosure is strictly prohibited. Please contact the sender by reply e-mail and delete all copies of this message from your computer system.

From: Erik Soderholm [mailto:erik@soderholmbus.com]
Sent: Sunday, August 2, 2020 4:00 PM
To: Jerrick Hernandez <jhernandez@guamopa.com>; Gustaf Soderholm <gus@soderholmbus.com>; Denise Soderholm <denise@soderholmbus.com>; Jessica Scheuring <jessica@soderholmbus.com>
Cc: fleetsales@triplejguam.com
Subject: Re: OPA-PA-20-006 Pre-Hearing Conference

Gus: Please register for us.

Aloha,

R. Erik Soderholm

Sent from my iPhone

On Aug 2, 2020, at 2:34 PM, Jerrick Hernandez <jhernandez@guamopa.com> wrote:

Hafa Adai,

You are invited to the Pre-Hearing Conference for OPA-PA-20-006 held via Zoom meeting.

When: Aug 4, 2020 02:00 PM Guam, Port Moresby

Register in advance for this meeting:

<https://zoom.us/meeting/register/tJwkf-iqrjsoHtMQtf6QxRHGKpAr4tKdPI6X>

After registering, you will receive a confirmation email containing information about joining the meeting.

Erik Soderholm

From: Erik Soderholm
Sent: Wednesday, July 22, 2020 3:02 PM
To: 'Jerrick Hernandez'; 'Robert Kono'; 'jbernard@mcdonald.law'
Cc: 'Christine Tedtaotao'; 'Claudia Acfalle'; Denise Soderholm; Gus Soderholm; Jessica Scheuring
Subject: RE: OPA-PA-20-006 Notice of Pre-Hearing Conference and Motion Filing Deadline

Jerrick: OK. Thank you. We confirm receipt. Here is an update;

- 1) My email remains erik@soderholmbus.com, the same email this notice was sent to & is on the cover sheet.
- 2) Please confirm the scheduled Zoom meeting is Tuesday, August 4, 2020 at 2:00 PM GST which is Monday August 3, 2020 at 6:00 PM HST?
- 3) Please include in the Zoom meeting our representative in Guam, Charlie Reynolds of Triple J. Motors at fleetsales@triplejguam.com.

Thank you.

R. Erik Soderholm
Vice President
Soderholm Sales & Leasing, Inc.
2044 Dillingham Blvd. Honolulu, HI 96819
Mailing address: P.O. Box 19010 Honolulu, HI 96817
808-834-1417 Fax 808-834-1070
erik@soderholmbus.com www.soderholmbus.com

This message **and any attachments** contain confidential information **and is the property of Soderholm Sales and Leasing, Inc. and/or Soderholm Mobility, Inc.** If you are not the intended recipient (or authorized to receive for the recipient) and received this message in error; any use, distribution or disclosure is strictly prohibited. Please contact the sender by reply e-mail and delete all copies of this message from your computer system.

From: Jerrick Hernandez [mailto:jhernandez@guamopa.com]
Sent: Tuesday, July 21, 2020 6:45 PM
To: Erik Soderholm <erik@soderholmbus.com>; Robert Kono <robert.kono@gsa.guam.gov>; jbernard@mcdonald.law
Cc: Christine Tedtaotao <christine.tedtaotao@gsadoa.guam.gov>; Claudia Acfalle <Claudia.Acfalle@gsadoa.guam.gov>
Subject: OPA-PA-20-006 Notice of Pre-Hearing Conference and Motion Filing Deadline

Hafa Adai,

Please see attached Notice of Pre-Hearing Conference and Motion Filing Deadline for OPA-PA-20-006.

Please confirm receipt of this email and the attached document.

--

Regards,

Jerrick J.J.G. Hernandez, MA, CGAP, CICA

Auditor

Office of Public Accountability – Guam

www.opaguam.org

Tel. (671) 475-0390 ext. 208

Fax (671) 472-7951

This e-mail transmission and accompanying attachment(s) may contain confidential or privileged information. If you are not the intended recipient of this e-mail, please inform the sender and delete it and any other electronic or hard copies immediately. Please do not distribute or disclose the contents to anyone. Thank you.

Erik Soderholm

From: Erik Soderholm <erik@soderholmbus.com> on behalf of Erik Soderholm
Sent: Tuesday, July 21, 2020 5:19 PM
To: Christine Tedtaotao
Cc: Denise Soderholm; Gus Soderholm; robert.kono@gsa.guam.gov; Claudia Acfalle; David Cruz; Anita Cruz; Jerrick Hernandez
Subject: Re: FOLLOW UP ON ACKNOWLEDGEMENT AGENCY REPORT PROCUREMENT APPEAL OPA-PA-20-006 Email 1 of 2

Christine: I need a phone call? Is that too much to ask?

Aloha,
R. Erik Soderholm

Sent from my iPhone

On Jul 21, 2020, at 3:50 PM, Christine Tedtaotao <Christine.Tedtaotao@gsadoa.guam.gov> wrote:

Sir requesting for your acknowledgement that you received the Procurement Appeal OPA-PA-20-006 BOOKS.

DUE to the file are big, the Agency Report is sent in 3 emails. If you can Acknowledge you received all 3 emails receiving Books 1 thru 4 of Agency Report.

From: Erik Soderholm [mailto:erik@soderholmbus.com]
Sent: Wednesday, July 22, 2020 11:41 AM
To: Christine Tedtaotao <Christine.Tedtaotao@gsadoa.guam.gov>
Cc: Denise Soderholm <denise@soderholmbus.com>; Gus Soderholm <gus@soderholmbus.com>; robert.kono@gsa.guam.gov; Claudia Acfalle <Claudia.Acfalle@gsadoa.guam.gov>; David Cruz <David.Cruz@gsadoa.guam.gov>; Anita Cruz <Anita.Cruz@gsadoa.guam.gov>; Jerrick Hernandez <jhernandez@guamopa.com>; Denise Soderholm <denise@soderholmbus.com>
Subject: Re: FOLLOW UP ON ACKNOWLEDGEMENT AGENCY REPORT PROCUREMENT APPEAL OPA-PA-20-006 Email 1 of 2

Christine: Not sure what I'm supposed to do? I have left numerous messages with you? You have never returned my call? Why?

Aloha,
R. Erik Soderholm

Sent from my iPhone

On Jul 21, 2020, at 3:34 PM, Christine Tedtaotao
<Christine.Tedtaotao@gsadoa.guam.gov> wrote:

Buenas yan Håfa Adai Erik,

I am currently following up on the Acknowledgement Form, for the "Agency Report, Books 1 of 4" .Please see attach document for for PROCUREMENT APPEAL OPA-PA-20-006 AGENCY REPORT

I kindly ask your assistance in filling out the "Acknowledgement " and forward back via

***email to gsaprocurment@gsadoa.guam.gov cc:
christine.tedtaotao@gsadoa.guam.gov***

Should you have any questions or concerns you may submitted in writing and forward via email or fax to GSA or you may contact me at 475-1705.

Your Response to this Matter is Urgent and Greatly Appreciated.

<image002.jpg>

Si Yu'os Ma'åse'

*Christine M. Tedtaotao
General Services Agency, Buyer II
Division of Department of Administration
Phone No. 671-475-1705
Email: gsaprocurment@gsadoa.guam.gov
christine.tedtaotao@gsadoa.guam.gov
Web Site: www.gsa.doa.guam.gov*

From: Christine Tedtaotao
Sent: Friday, July 17, 2020 5:07 PM
To: 'Erik Soderholm' <erik@soderholmbus.com>
Cc: robert.kono@gsa.guam.gov; Claudia Acfalle <Claudia.Acfalle@gsadoa.guam.gov>; David Cruz <David.Cruz@gsadoa.guam.gov>; Anita Cruz <Anita.Cruz@gsadoa.guam.gov>
Subject: AGENCY REPORT PROCUREMENT APPEAL OPA-PA-20-006 (Email 1 of 3)
Importance: High

<Book 1 of 4 AGENCY REPORT .PDF>

Erik Soderholm

From: Erik Soderholm <erik@soderholmbus.com> on behalf of Erik Soderholm
Sent: Sunday, July 12, 2020 2:19 PM
To: Jerrick Hernandez
Cc: Christine Tedtaotao; robert.kono@gsa.guam.gov; Claudia Acfalle; David Cruz; Anita Cruz; Charlie Renoylds; Denise Soderholm; Gustaf Soderholm; Jessica Scheuring
Subject: Re: PROCUREMENT APPEAL OPA-PA-20-006 PROCUREMENT books 1 through 3 of 4

Jerrick: OK. Thank you.

I think you should be cced on all communication between us? They did not do that? They have never communicated to me before after 50+ phone messages & emails. This is a great new start. But we owe it all to you & the process.

We will review.

Aloha,
R. Erik Soderholm

Sent from my iPhone

On Jul 12, 2020, at 12:36 PM, Jerrick Hernandez <jhernandez@guamopa.com> wrote:

Hafa Adai Mr. Soderholm,

For clarification purposes, GSA, as the Purchasing Agency, is doing what is required of them in the procurement appeals process. As seen in the flowchart (http://opaguam.org/sites/default/files/pa_flowchart.pdf), the Purchasing Agency must submit the Procurement Record within 5 working days to the OPA after receiving Notice of Receipt of Appeal. They must also submit the Agency Report to the OPA within 10 working days after receiving the notice. Your organization as the Appellant will then have 10 calendar days to file Comments on the Agency Report. Lastly, the Purchasing Agency is able to provide a rebuttal on the Appellant's comments within 5 working days after receiving them. You may refer to other procurement appeals for examples of this process at <http://opaguam.org/procurement-appeals/search-procurement-appeals>.

Generally, the parties must provide each other party a copy of any documents filed with the OPA throughout the procurement appeal. In addition, the parties should be able to communicate with each other whenever necessary and do not require OPA's participation, unless at a requested or scheduled hearing conference.

Please feel free to contact me, should you have any additional questions or need clarifications.

--

Regards,

Jerrick J.J.G. Hernandez, MA, CGAP, CICA

Auditor

Office of Public Accountability – Guam

www.opaguam.org

Tel. (671) 475-0390 ext. 208

Fax (671) 472-7951

This e-mail transmission and accompanying attachment(s) may contain confidential or privileged information. If you are not the intended recipient of this e-mail, please inform the sender and delete it and any other electronic or hard copies immediately. Please do not distribute or disclose the contents to anyone. Thank you.

On Sat, Jul 11, 2020 at 12:34 AM Erik Soderholm <erik@soderholmbus.com> wrote:

Christine: I'm confused what you want me to do?

We have appealed our protest denial from GSA to the Auditor? Why are we back dealing directly with GSA? You, Anita, Robert & Claudia have repeatedly ignored me?

What do you want me to do?

Is this even legal for GSA to contact us directly & not go thru the Auditor during a protest appeal?

Aloha,

R. Erik Soderholm

Sent from my iPhone

On Jul 9, 2020, at 9:36 PM, Christine Tedtaotao
<Christine.Tedtaotao@gsadoa.guam.gov> wrote:

Buenas yan Håfa Adai, PROCUREMENT APPEAL OPA-PA-20-006 PROCUREMENT

Please see attach document for books 1 through 3 of 4 see email 2 for Book 4

I kindly ask your assistance in filling out the "Acknowledgement" and forward back via

*email to gsaprocurement@gsadoa.guam.gov cc:
christine.tedtaotao@gsadoa.guam.gov*

Should you have any questions or concerns you may submitted in writing and forward via email or fax to GSA or you may contact me at 475-1705.

Your Response to this Matter is Urgent and Greatly Appreciated.

Si Yu'os Ma'åse'

Christine M. Tedtaotao

General Services Agency, Buyer II

Division of Department of Administration

Phone No. 671-475-1705

Email: gsaprocurement@gsadoa.guam.gov

christine.tedtaotao@gsadoa.guam.gov

Web Site: www.gsa.doa.guam.gov

<PROCUREMENT APPEAL 1 BOOK.PDF>

<PAppeal Book 2.PDF>

<PROCUREMENT APPEAL 3.PDF>

Erik Soderholm

From: Jerrick Hernandez <jhernandez@guamopa.com> on behalf of Jerrick Hernandez
Sent: Wednesday, July 08, 2020 6:54 PM
To: Robert Kono
Cc: erik@soderholmbus.com
Subject: Re: submission of procurement record for OPA-PA-20-006 ((GRtA))

Hafa Adai Mr. Kono,

Correction: The Agency Report will be extended to Friday, July 17, 2020, not July 19, 2020 (this is a Sunday).

On Mon, Jul 6, 2020 at 5:50 PM Jerrick Hernandez <jhernandez@guamopa.com> wrote:
Hafa Adai Mr. Kono,

The Public Auditor is granting your request for extension in filing the Procurement Record for OPA-PA-20-006 on July 10, 2020 and Agency Report on July 19, 2020.

On Mon, Jul 6, 2020, 12:28 PM Robert Kono <robert.kono@gsa.guam.gov> wrote:
Mr. Hernandez: Due to large file size on the above entitled matter, GSA respectfully requests that it be allowed to submit the procurement record on Friday, July 10th, rather than July 7th (Correspondingly the agency report to be filed on the 19th). Your approval would be greatly appreciated....rhkono,

--

Regards,

Jerrick J.J.G. Hernandez, MA, CGAP, CICA
Auditor
Office of Public Accountability – Guam
www.opaguam.org
Tel. (671) 475-0390 ext. 208
Fax (671) 472-7951

This e-mail transmission and accompanying attachment(s) may contain confidential or privileged information. If you are not the intended recipient of this e-mail, please inform the sender and delete it and any other electronic or hard copies immediately. Please do not distribute or disclose the contents to anyone. Thank you.

Erik Soderholm

From: Erik Soderholm <erik@soderholmbus.com> on behalf of Erik Soderholm
Sent: Sunday, June 28, 2020 2:01 PM
To: Office of Public Accountability
Cc: Claudia Acfalle; Anita Cruz; Robert Kono; Christine Tedtaotao; Celestin Babauta; Rally M. Pilipina; Catherine Blas; Charlie Renoynlds; Denise Soderholm; Gus Soderholm; Jessica Scheuring; Jeffrey Miller; Jerrick Hernandez; Benjamin Cruz; dhendrixson@forestriverinc.com; rryff@forestriverinc.com
Subject: Re: Appeal to GSA-055-19 Protest Denial on 6/22/20

Jerrick: OK. Happy Days! Thank you for the confirmation.

We look forward to working with you to resolve our appeal.

Aloha.

Sent from my iPhone

On Jun 28, 2020, at 1:28 PM, Office of Public Accountability <admin@guamopa.com> wrote:

Hafa Adai Mr. Soderholm,

Please see attached OPA stamped receipt of your appeal filing. The official Notice of Receipt of Appeal will be sent to all parties shortly.

For future correspondence, please email me at jhernandez@guamopa.com.

--

Regards,

Jerrick J.J.G. Hernandez, MA, CGAP, CICA
Auditor
Office of Public Accountability – Guam
www.opaguam.org
Tel. (671) 475-0390 ext. 208
Fax (671) 472-7951

This e-mail transmission and accompanying attachment(s) may contain confidential or privileged information. If you are not the intended recipient of this e-mail, please inform the sender and delete it and any other electronic or hard copies immediately. Please do not distribute or disclose the contents to anyone. Thank you.

On Sun, Jun 28, 2020 at 12:32 PM Erik Soderholm <erik@soderholmbus.com> wrote:

Public Auditor:

Please find the following attachments for your review;

- 1) Completed and signed Appendix A: Notice of Appeal Form.
- 2) Signed appeal stating the reasons for the appeal and action requested.
- 3) Copy of the appeal to the GSA dated 6/15/20.
- 4) Copy of the denial of our appeal dated 6/22/20 from the GSA.
- 5) Copy of email response dated 1/4/20 to Christine Tedtaotao of GSA responding to her request for clarification. In a subsequent conversation she accepted our clarification.
- 6) Copy of letter from Forest River, parent company of StarCraft Bus, the bus bid by Monster Auto Spot, stating that chassis after 3/1/19 GM/GMC chassis no longer meet the Buy America requirement of 70% domestic content.
- 7) Copy of bid abstract.
- 8) Copy of the Bid Status.

Would you please confirm receipt, and that the bid appeal was accepted by email per Chapter 12, 121104, Procurement Appeals to the Public Auditor?

Please call or email us any questions?

Please email to us any notices?

Thank you for your review.

R. Erik Soderholm

Vice President

Soderholm Sales & Leasing, Inc.

2044 Dillingham Blvd. Honolulu, HI 96819

Mailing address: P.O. Box 19010 Honolulu, HI 96817

808-834-1417 Fax 808-834-1070

erik@soderholmbus.com

www.soderholmbus.com

This message and any attachments contain confidential information and is the property of Soderholm Sales and Leasing, Inc. and/or Soderholm Mobility, Inc.. If you are not the intended recipient (or authorized to receive for the recipient) and received this message in error; any use, distribution or disclosure is strictly prohibited. Please contact the sender by reply e-mail and delete all copies of this message from your computer system.

<OPA-PA-20-006 OPA Stamp Receipt.pdf>

Erik Soderholm

From: Erik Soderholm <erik@soderholmbus.com> on behalf of Erik Soderholm
Sent: Sunday, June 28, 2020 10:23 AM
To: admin@guamopa.com
Cc: Claudia Acfalle; Anita Cruz; Robert Kono; Christine Tedtaotao; Celestin Babauta; Rally M. Pilipina; Catherine Blas; Charlie Renoylds; Denise Soderholm; Gus Soderholm; Jessica Scheuring; Jeffrey Miller; dhendrixson@forestriverimc.com; rryff@forestriverinc.com
Subject: Re: Appeal to GSA-055-19 Protest Denial on 6/22/20

Folks: Would you please confirm receipt today?

Aloha.

Sent from my iPhone

On Jun 27, 2020, at 4:31 PM, Erik Soderholm <erik@soderholmbus.com> wrote:

Public Auditor:

Please find the following attachments for your review;

- 1) Completed and signed Appendix A: Notice of Appeal Form.
- 2) Signed appeal stating the reasons for the appeal and action requested.
- 3) Copy of the appeal to the GSA dated 6/15/20.
- 4) Copy of the denial of our appeal dated 6/22/20 from the GSA.
- 5) Copy of email response dated 1/4/20 to Christine Tedtaotao of GSA responding to her request for clarification. In a subsequent conversation she accepted our clarification.
- 6) Copy of letter from Forest River, parent company of StarCraft Bus, the bus bid by Monster Auto Spot, stating that chassis after 3/1/19 GM/GMC chassis no longer meet the Buy America requirement of 70% domestic content.
- 7) Copy of bid abstract.
- 8) Copy of the Bid Status.

Would you please confirm receipt, and that the bid appeal was accepted by email per Chapter 12, 121104, Procurement Appeals to the Public Auditor?

Please call or email us any questions?

Please email to us any notices?

Thank you for your review.

R. Erik Soderholm
Vice President
Soderholm Sales & Leasing, Inc.
2044 Dillingham Blvd. Honolulu, HI 96819
Mailing address: P.O. Box 19010 Honolulu, HI 96817
808-834-1417 Fax 808-834-1070
erik@soderholmbus.com www.soderholmbus.com

This message and any attachments contain confidential information and is the property of Soderholm Sales and Leasing, Inc. and/or Soderholm Mobility, Inc.. If you are not the intended recipient (or authorized to receive for the recipient) and received this message in error; any use, distribution or disclosure is strictly prohibited. Please contact the sender by reply e-mail and delete all copies of this message from your computer system.

<ERIKS0372.pdf>
<ERIKS0373.pdf>
<ERIKS0374.pdf>
<ERIKS0375.pdf>
<ERIKS0376.pdf>
<ERIKS0377.pdf>
<ERIKS0378.pdf>
<ERIKS0379.pdf>

Erik Soderholm

From: Erik Soderholm <erik@soderholmbus.com> on behalf of Erik Soderholm
Sent: Sunday, June 28, 2020 3:26 PM
To: Jerrick Hernandez
Cc: Robert Kono; Claudia Acfalle; Denise Soderholm; Gustaf Soderholm
Subject: Re: OPA-PA-20-006 Notice of Receipt of Appeal

Jerrick: Yes. Received.

Thank you.

Aloha,
R. Erik Soderholm

Sent from my iPhone

On Jun 28, 2020, at 2:48 PM, Jerrick Hernandez <jhernandez@guamopa.com> wrote:

Hafa Adai!

Please see attached Notice of Receipt of Appeal for OPA-PA-20-006. The Notice was also faxed to GSA.

Please confirm receipt of this email and the attached document.

--

Regards,

Jerrick J.J.G. Hernandez, MA, CGAP, CICA
Auditor
Office of Public Accountability – Guam
www.opaguam.org
Tel. (671) 475-0390 ext. 208
Fax (671) 472-7951

This e-mail transmission and accompanying attachment(s) may contain confidential or privileged information. If you are not the intended recipient of this e-mail, please inform the sender and delete it and any other electronic or hard copies immediately. Please do not distribute or disclose the contents to anyone. Thank you.

<20-006 Notice of Receipt of Appeal.pdf>

Erik Soderholm

From: Fujii, Ryan (FTA) <ryan.fujii@dot.gov> on behalf of Fujii, Ryan (FTA)
Sent: Friday, June 26, 2020 2:54 PM
To: Erik Soderholm
Cc: Claudia Acfalle; Anita Cruz; Robert Kono; Denise Soderholm; Gus Soderholm; Jessica Scheuring; Charlie Reynolds; Jeffrey Miller; Bustamante, Bernardo (FTA)
Subject: RE: GSA-055-19 Response

Mr. Soderholm.

That is the correct email for Mr. Tellis. I would recommend emailing him a pdf of your protest.

Thank you,

Ryan Fujii
General Engineer
U.S. Department of Transportation
Federal Transit Administration, Region 9
300 Ala Moana Blvd., Room 3-306
Honolulu, Hawaii 96850
Email: ryan.fujii@dot.gov
Phone: (202) 748 - 0677

From: Erik Soderholm [mailto:erik@soderholmbus.com]
Sent: Friday, June 26, 2020 2:09 PM
To: Fujii, Ryan (FTA) <ryan.fujii@dot.gov>
Cc: Claudia Acfalle <Claudia.Acfalle@gsadoa.guam.gov>; Anita Cruz <Anita.Cruz@gsadoa.guam.gov>; Robert Kono <robert.kono@gsa.guam.gov>; Denise Soderholm <denise@soderholmbus.com>; Gus Soderholm <gus@soderholmbus.com>; Jessica Scheuring <jessica@soderholmbus.com>; Charlie Reynolds <charlie.reynolds@triplejhq.com>; Jeffrey Miller <jeff@millershealaw.com>; Bustamante, Bernardo (FTA) <Bernardo.Bustamante@dot.gov>
Subject: RE: GSA-055-19 Response

CAUTION: This email originated from outside of the Department of Transportation (DOT). Do not click on links or open attachments unless you recognize the sender and know the content is safe.

Ryan: OK. Should we email the appeal to Ray? Do you have an email address? Is it Ray.Tellis@dot.gov?

Thank you.

R. Erik Soderholm
Vice President
Soderholm Sales & Leasing, Inc.
2044 Dillingham Blvd. Honolulu, HI 96819
Mailing address: P.O. Box 19010 Honolulu, HI 96817
808-834-1417 Fax 808-834-1070
erik@soderholmbus.com www.soderholmbus.com

This message and any attachments contain confidential information and is the property of Soderholm Sales and Leasing, Inc. and/or Soderholm Mobility, Inc.. If you are not the intended recipient (or authorized to receive for the recipient) and received this message in error; any use, distribution or disclosure is strictly prohibited. Please contact the sender by reply e-mail and delete all copies of this message from your computer system.

From: Fujii, Ryan (FTA) [mailto:ryan.fujii@dot.gov]

Sent: Friday, June 26, 2020 1:59 PM

To: Erik Soderholm <erik@soderholmbus.com>

Cc: Claudia Acfalle <Claudia.Acfalle@gsadoa.guam.gov>; Anita Cruz <Anita.Cruz@gsadoa.guam.gov>; Robert Kono <robert.kono@gsa.guam.gov>; Denise Soderholm <denise@soderholmbus.com>; Gus Soderholm <gus@soderholmbus.com>; Jessica Scheuring <jessica@soderholmbus.com>; Charlie Reynolds <charlie.reynolds@triplejhq.com>; Jeffrey Miller <jeff@millershealaw.com>; Bustamante, Bernardo (FTA) <Bernardo.Bustamante@dot.gov>

Subject: Re: GSA-055-19 Response

No form. It should be addressed to the Regional Administrator Ray Tellis

Get [Outlook for iOS](#)

From: Erik Soderholm <erik@soderholmbus.com>

Sent: Friday, June 26, 2020 12:08:57 PM

To: Fujii, Ryan (FTA) <ryan.fujii@dot.gov>

Cc: Claudia Acfalle <Claudia.Acfalle@gsadoa.guam.gov>; Anita Cruz <Anita.Cruz@gsadoa.guam.gov>; Robert Kono <robert.kono@gsa.guam.gov>; Denise Soderholm <denise@soderholmbus.com>; Gus Soderholm <gus@soderholmbus.com>; Jessica Scheuring <jessica@soderholmbus.com>; Charlie Reynolds <charlie.reynolds@triplejhq.com>; Jeffrey Miller <jeff@millershealaw.com>; Bustamante, Bernardo (FTA) <Bernardo.Bustamante@dot.gov>

Subject: RE: GSA-055-19 Response

CAUTION: This email originated from outside of the Department of Transportation (DOT). Do not click on links or open attachments unless you recognize the sender and know the content is safe.

Ryan: OK. Who in the FTA do we send it to? You? We already sent it to you earlier this week? Is that good enough? Is there a an appeal form we are to fill out?

Thank you.

R. Erik Soderholm
Vice President
Soderholm Sales & Leasing, Inc.
2044 Dillingham Blvd. Honolulu, HI 96819
Mailing address: P.O. Box 19010 Honolulu, HI 96817
808-834-1417 Fax 808-834-1070
erik@soderholmbus.com www.soderholmbus.com

This message and any attachments contain confidential information and is the property of Soderholm Sales and Leasing, Inc. and/or Soderholm Mobility, Inc.. If you are not the intended recipient (or authorized to receive for the recipient) and received this message in error; any use, distribution or disclosure is strictly prohibited. Please contact the sender by reply e-mail and delete all copies of this message from your computer system.

From: Fujii, Ryan (FTA) [mailto:ryan.fujii@dot.gov]

Sent: Friday, June 26, 2020 11:54 AM

To: Erik Soderholm <erik@soderholmbus.com>

Cc: Claudia Acfalle <Claudia.Acfalle@gsadoa.guam.gov>; Anita Cruz <Anita.Cruz@gsadoa.guam.gov>; Robert Kono <robert.kono@gsa.guam.gov>; Denise Soderholm <denise@soderholmbus.com>; Gustaf Soderholm <gus@soderholmbus.com>; Jessica Scheuring <jessica@soderholmbus.com>; Charlie Reynolds <charlie.reynolds@triplejhq.com>; Jeffrey Miller <jeff@millershealaw.com>; Bustamante, Bernardo (FTA) <Bernardo.Bustamante@dot.gov>

Subject: RE: GSA-055-19 Response

Mr. Soderholm,

Below are the procedures for filing a third party procurement protest with FTA.

(1) Requirements for the Protester. The protester must:

- (a) Qualify as an “Interested Party.” Only an “interested party” qualifies for FTA review of its appeal. An “interested party” is a party that is an actual or prospective bidder or offeror whose direct economic interest would be affected by the award or failure to award the third party contract at issue.
- 1 Subcontractors. A subcontractor does not qualify as an “interested party” because it does not have a direct economic interest in the results of the procurement.
 - 2 Consortia/Joint Ventures/Partnerships/Teams. An established consortium, joint venture, partnership, or team that is an actual bidder or offeror and is acting in its entirety, would qualify as an “interested party” because it has a direct economic interest in the results of the procurement. An individual member of a consortium, joint venture, partnership, or team, acting solely in its individual capacity, does not qualify as an “interested party” because it does not have a direct economic interest in the results of the procurement.
 - 3 Associations or Organizations. An association or organization that does not perform contracts does not qualify as an “interested party,” because it does not have a direct economic interest in the results of the procurement.
- (b) Exhaust Administrative Remedies. The protester must exhaust its administrative remedies by pursuing the recipient’s protest procedures to completion before appealing the recipient’s decision to FTA.
- (c) Appeal Within Five Days. The protester must deliver its appeal to the FTA Regional Administrator for the region administering its project or the FTA Associate Administrator for the program office administering its project within five (5) working days of the date when the protester has received actual or constructive notice of the recipient’s final decision. Likewise, the protester must provide its appeal to the FTA Regional Administrator for the region

administering its project or the FTA Associate Administrator for the program office administering its project within five (5) working days of the date when the protester has identified other grounds for appeal to FTA. For example, other grounds for appeal include the recipient's failure to have or failure to comply with its protest procedures or failure to review the protest.

In terms of the Buy America compliance, FTA will review the procurement as part of its oversight role to determine if the procurement is in compliance with Buy America requirements. If the procurement is not in compliance with Buy America requirements, then the procurement would not be eligible for federal funds.

Thank you,

Ryan Fujii
General Engineer
U.S. Department of Transportation
Federal Transit Administration, Region 9
300 Ala Moana Blvd., Room 3-306
Honolulu, Hawaii 96850
Email: ryan.fujii@dot.gov
Phone: (202) 748 - 0677

From: Erik Soderholm [<mailto:erik@soderholmbus.com>]

Sent: Friday, June 26, 2020 11:21 AM

To: Fujii, Ryan (FTA) <ryan.fujii@dot.gov>

Cc: Claudia Acfalle <Claudia.Acfalle@gsadoa.guam.gov>; Anita Cruz <Anita.Cruz@gsadoa.guam.gov>; Robert Kono <robert.kono@gsa.guam.gov>; Denise Soderholm <denise@soderholmbus.com>; Gustaf Soderholm <gus@soderholmbus.com>; Jessica Scheuring <jessica@soderholmbus.com>; Charlie Reynolds <charlie.reynolds@triplejhq.com>; Jeffrey Miller <jeff@millershealaw.com>; Bustamante, Bernardo (FTA) <Bernardo.Bustamante@dot.gov>

Subject: Re: GSA-055-19 Response

CAUTION: This email originated from outside of the Department of Transportation (DOT). Do not click on links or open attachments unless you recognize the sender and know the content is safe.

Ryan: OK. Thank you for returning my call?

Would you please email us the FTA appeal procedures for the FTA Buy America? We will appeal to the FTA because as you can plainly see the Buy America Pre-Award certificate is defective - I have never seen in my 30+ years & reviewing hundreds of Buy America certificates a Buy America have an unaccounted amount?

We are sure the FTA will not allow defective Buy America certificates.

We are also appealing the GSA procurement protest denial.

Would you please email us the FTA Buy America procedures today?

Thank you.

Sent from my iPhone

On Jun 26, 2020, at 10:50 AM, Fujii, Ryan (FTA) <ryan.fujii@dot.gov> wrote:

Mr. Soderholm,

In regards to procurements, bidders shall follow the Grantee's procedures for appeal, FTA will not substitute its judgment for the Grantee's judgment in procurement decisions.

In terms of the Buy America compliance, FTA will review the procurement as part of its oversight role to determine if the procurement is in compliance with Buy America requirements. If the procurement is not in compliance with Buy America requirements, then the procurement would not be eligible for federal funds.

If you choose to appeal to FTA, you must do so within 5 days of the denial.

Thank you,

Ryan Fujii
General Engineer
U.S. Department of Transportation
Federal Transit Administration, Region 9
300 Ala Moana Blvd., Room 3-306
Honolulu, Hawaii 96850
Email: ryan.fujii@dot.gov
Phone: (202) 748 - 0677

From: Erik Soderholm [<mailto:erik@soderholmbus.com>]
Sent: Tuesday, June 23, 2020 6:24 PM
To: Fujii, Ryan (FTA) <ryan.fujii@dot.gov>
Cc: Claudia Acfalle <Claudia.Acfalle@gsadoa.guam.gov>; Anita Cruz <anita.cruz@gsadoa.guam.gov>; Robert Kono <robert.kono@gsa.guam.gov>; Denise Soderholm <denise@soderholmbus.com>; Gustaf Soderholm <gus@soderholmbus.com>; Jessica Scheuring <jessica@soderholmbus.com>; Charlie Reynolds <charlie.reynolds@triplejhq.com>; Jeffrey Miller <jeff@millershealaw.com>
Subject: Fwd: GSA-055-19 Response

CAUTION: This email originated from outside of the Department of Transportation (DOT). Do not click on links or open attachments unless you recognize the sender and know the content is safe.

Ryan: Please see attached the denial of our protest from the GSA Guam bid for your review.

We provided them & you with a letter from Forest River, the parent company of StarCraft Bus, the bus manufacturer that the high-bidder, Monster Auto Spot, bid showing the GM/GMC chassis they bid does not meet Buy America.

Would you please confirm that the FTA will not fund this deal?

Thank you.

Sent from my iPhone

Begin forwarded message:

From: gsaprourement <gsaprourement@gsadoa.guam.gov>
Date: June 23, 2020 at 3:11:56 PM HST
To: Erik Soderholm <erik@soderholmbus.com>
Cc: Claudia Acfalle <Claudia.Acfalle@gsadoa.guam.gov>, Anita Cruz <Anita.Cruz@gsadoa.guam.gov>, Robert Kono <robert.kono@gsa.guam.gov>
Subject: GSA-055-19 Response

Hafa adai,

Please see the following attachment in regards to GSA bid GSA-055-19 and kindly acknowledge upon receipt of this email and forward back via:

gsaprourement@gsadoa.guam.gov.

Your immediate response is greatly appreciated.

Thank you,

GSA Procurement
General Services Agency
GovGuam
(671) 475-1707

Erik Soderholm

From: Erik Soderholm <erik@soderholmbus.com> on behalf of Erik Soderholm
Sent: Tuesday, August 04, 2020 6:13 AM
To: Jerrick Hernandez
Cc: Matthew E. Wolff; Charles McDonald; Denise Soderholm; fleetsales@triplejguam.com; Robert Kono; Clariza Roque
Subject: Re: OPA-PA-20-006 Notice of Hearing RE Appellant's Appeal

Jerrick: OK. Received again. Thank you.

Aloha,
R. Erik Soderholm

Sent from my iPhone

On Aug 3, 2020, at 8:28 PM, Jerrick Hernandez <jhernandez@guamopa.com> wrote:

Hafa Adai,

Please see attached Notice of Hearing RE Appellant's Appeal for OPA-PA-20-006. This email will serve as an official notice in lieu of a transmittal via Fax.

Please confirm receipt of this email and the attached document. Thank you.

--

Regards,

Jerrick J.J.G. Hernandez, MA, CGAP, CICA
Auditor
Office of Public Accountability – Guam
www.opaguam.org
Tel. (671) 475-0390 ext. 208
Fax (671) 472-7951

This e-mail transmission and accompanying attachment(s) may contain confidential or privileged information. If you are not the intended recipient of this e-mail, please inform the sender and delete it and any other electronic or hard copies immediately. Please do not distribute or disclose the contents to anyone. Thank you.

<20-006 Notice of Hearing.pdf>

Erik Soderholm

From: Erik Soderholm
Sent: Wednesday, June 24, 2020 3:43 PM
To: 'gsaprocedurement'
Cc: 'Claudia Acfalle'; 'Anita Cruz'; 'Robert Kono'; 'Christine Tedtaotao'; 'Celestin Babauta'; 'Rally M. Pilipina'; 'Catherine Blas'; Denise Soderholm; Gus Soderholm; Jessica Scheuring; 'Jeffrey Miller'; 'Charlie Reynolds'; 'dhendrixson@forestriverinc.com'; 'ruffy@forestriverinc.com'; 'ryan.fujii@dot.gov'
Subject: RE: GSA-055-19 Response
Attachments: ERIKS0365.pdf, ERIKS0366.pdf

Claudia: We disagree for the following reasons including;

. Protest issue 3: You said "Our bid was the lowest responsive and responsible bid. GSA response: Agree,..." That is the end of the story. Responsive and responsible means we met all the terms of the bid which we did.

. Protest issue 4: Christine Tedtaotao asked for a clarification on the very confusing bid specifications. She said she was satisfied with our clarification on the wheelchair lift location.

. Protest issue 5: You left off our protest after "...EIDorado. See also attached letter date 1/24/19 from Forest River, parent company of StarCraft, the bus manufacturer bid by Monster Auto Spot, saying that the GM/GMC Chassis does not meet Buy America", as that was did not align with your narrative. The Forest River letter dated 1/24/19 attached from Jerry Cavanah, Government Bids, is specific saying "After this March 1, 2019 deadline, GM chassis will not be considered on FTA-funded vehicle purchases due to the new 70% domestic content requirement." Moreover the GRTA Director has no authority or knowledge to certify the buses met Buy America. Additionally, the 2/17/20 Pre-Award BUY AMERICA CERTIFICATION signed by Scott Defrees is deficient and suspect as it doesn't account for 4.55% which is in the margin of error for their 73.49% U.S. CONTENT, is in conflict with the 1/24/19 letter from Forest River and was added on 2/17/19 after the fact of the bid opening on 11/15/19 which is illegal. We had a Buy America certification with our bid on opening on 11/15/19 which is what was required.

Protest 7: Although you did restate our objection including "For over 6 months I have left numerous phone message & sent numerous emails to you both to no avail. There was absolutely no common courtesy to return my calls or emails". You never addressed this objection because it was inconvenient. This violates the law, procurement regulations and FTS procurement guidelines.

We would like to appeal this protest denial thru an administrative or judicial review. Please provide the process?

Thank you.

R. Erik Soderholm
Vice President
Soderholm Sales & Leasing, Inc.
2044 Dillingham Blvd. Honolulu, HI 96819 Mailing address: P.O. Box 19010 Honolulu, HI 96817
808-834-1417 Fax 808-834-1070
erik@soderholmbus.com www.soderholmbus.com

This message and any attachments contain confidential information and is the property of Soderholm Sales and Leasing, Inc. and/or Soderholm Mobility, Inc.. If you are not the intended recipient (or authorized to receive for the recipient) and received this message in error; any use, distribution or disclosure is strictly prohibited. Please contact the sender by reply e-mail and delete all copies of this message from your computer system.

-----Original Message-----

From: gsaprourement [mailto:gsaprourement@gsadoa.guam.gov]

Sent: Tuesday, June 23, 2020 3:09 PM

To: Erik Soderholm <erik@soderholmbus.com>

Cc: Claudia Acfalle <Claudia.Acfalle@gsadoa.guam.gov>; Anita Cruz <Anita.Cruz@gsadoa.guam.gov>;

Robert Kono <robert.kono@gsa.guam.gov>

Subject: GSA-055-19 Response

Hafa adai,

Please see the following attachment in regards to GSA bid GSA-055-19 and kindly acknowledge upon receipt of this email and forward back via: gsaprourement@gsadoa.guam.gov.
Your immediate response is greatly appreciated.

Thank you,

GSA Procurement
General Services Agency
GovGuam
(671) 475-1707

Erik Soderholm

From: Erik Soderholm
Sent: Friday, June 12, 2020 3:01 PM
To: 'Christine Tedtaotao'
Cc: 'claudia.acfalle@gsadoa.guam.gov'; 'Anita Cruz'; 'David.Cruz@gsadoa.guam.gov'; 'robert.kono'; 'Catherine Blas'; 'Rally M. Pilipina'; 'Celestin Babauta'; 'Charlie Reynolds'; Denise Soderholm; Gus Soderholm; Jessica Scheuring; 'ryan.fujii@dot.gov'
Subject: FW: GSA-055-20 Bid Status
Attachments: GSA-055-19 Bid Status .pdf; ERIKS0339.pdf; ERIKS0341.pdf; ERIKS0342.pdf
Importance: High

Christine: We respectfully protest the decision by General Service Agency (GSA) to award GSA-055-19 bid to Monster Auto Spot for the following reasons:

- 1) Our bid was \$158,700.00 per bus which is \$4,474.20 less than Monster Auto Spot's bid of \$163,174.20.
- 2) We met all the terms of the bid, as evidenced by the attached bid abstract.
- 3) Our bid was the lowest responsive and responsible bid.
- 4) You sent us a questions about the location of the wheelchair lift, we responded on 1/4/20 with the attached email questioning the confusing bid instructions on page 45 of the specifications, and offering the floor plan with the preferred front lift at no additional cost? Specifications are routinely adjusted at preproduction meetings? You said you were satisfied in a subsequent phone conversation.
- 5) We told you that the GM/GMC/Savanna chassis that Monster Auto Spot bid, no longer meets Buy America, due to too much foreign content which disallows these buses to be purchased using Federal Transportation Agency (FTA) funds. See attached letter from EIDorado. On page 40, included in the Special Provisions, #23 states that vehicles must "comply with all FTA Buy America/ADA requirement..."
- 6) EIDorado was purchased by Forest River, Inc. on 5/8/20, the parent company of Starcraft, the bus manufacturer that Monster Auto Spot bid. The same Buy America failure applies to all GM/GMC/Savanna chassis that Forest River/Starcraft uses for Starcraft buses that Monster Auto Spot bid. See attached press release from Forest River for your review.
- 7) I was only able to talk to you on the phone twice last year, and Anita Cruz once. You have said the bid was with the Attorney General's office? For over 6 months I have left numerous phone messages & sent numerous emails to you both to no avail. There was absolutely no common courtesy to return my calls or emails.
- 8) We talked to Ryan Fujii, the head to the FTA Pacific office in Honolulu. He assured us that the FTA will not fund a bid that for buses don't meet Buy America.
- 9) We will not sign your attached Bid Status. It is unfair, violates the law & FTA guidelines.
- 10) We request the bid be awarded to us, or at the very least the bid be cancelled, and rebid to clarify the numerous discrepancies, and that the bid was opened over 6 months ago which is an unbelievable long period of time to award a low bid.

Thank you for your review. Please get back to us with any questions by calling or email?

R. Erik Soderholm
Vice President
Soderholm Sales & Leasing, Inc.
2044 Dillingham Blvd. Honolulu, HI 96819
Mailing address: P.O. Box 19010 Honolulu, HI 96817
808-834-1417 Fax 808-834-1070
erik@soderholmbus.com www.soderholmbus.com

This message **and any attachments** contain confidential information **and is the property of Soderholm Sales and Leasing, Inc. and/or Soderholm Mobility, Inc.** If you are not the intended recipient (or authorized to receive for the recipient) and received this message in error; any use, distribution or disclosure is strictly prohibited. Please contact the sender by reply e-mail and delete all copies of this message from your computer system.

From: Christine Tedtaotao [mailto:Christine.Tedtaotao@gsadoa.guam.gov]
Sent: Thursday, June 11, 2020 8:23 PM
To: Erik Soderholm <erik@soderholmbus.com>
Cc: David Cruz <David.Cruz@gsadoa.guam.gov>
Subject: GSA-055-20 Bid Status
Importance: High

Buenas yan Hafa Adai,

Please see attach document reference to GSA-055-19 GRTA 14 Passenger ADA- Compliant Buses.
I kindly ask you to please fill out Vendor acknowledgement and resubmit back to GSA via email.

Thank you
Christine Tedtaotao
GSA-Buyer
475-1705

Erik Soderholm

From: Celestin Babauta <celestin.babauta@grta.guam.gov> on behalf of Celestin Babauta
Sent: Wednesday, April 15, 2020 2:10 PM
To: Erik Soderholm; Rally M. Pilipina; Claudia Acfalle
Subject: Re: Coronavirus Aid, Relief, and Economic Security (CARES) Act Grant Marketing Research

Erik,

I ask that we focus on the Emergency Procurement marketing research that Rally is working on. We would like you and all interested firms to have an opportunity.

With respect to the bid that I believe you are referring to, GRTA submitted the procurement package to the Attorney General's office for review and from there we forward the package to GSA. GSA manages all of GRTA's procurement to include vehicles.

GRTA does not do procurement and we do our best with what we have to provide transit services for the people of Guam

Please refer all of your questions regarding procurement to GSA.

We appreciate your cooperation.
Best Regards,
Celestin (Cel) C. Babauta, MS WED
Interim Executive Manager
(671) 300-7260



On Thu, Apr 16, 2020 at 2:55 AM Erik Soderholm <erik@soderholmbus.com> wrote:

Rally: OK. Would you please email us a copy of the Guam regulations that prohibit contact with a bidder on a low bid after bid opening but before award? There is no such law in Hawaii, across the U.S. or with the FTA? We are in weekly contact with all 4 transit agencies in Hawaii? There is no legitimate purpose to have no contact after a low bid opening? How can you contact us on this new request? Why isn't GSA contacting us?

GSA has been in contact with GRTA on the bid?
There has been no decision for 6 months?
Has the bid been awarded to Auto Spot?
We communicated to GSA:

- The GMC chassis that Auto Spot bid no longer meets the new 70% U.S. content for Buy America to receive FTA funds.
We bid the Ford E-450 chassis thru Triple J to get warranty in Guam that meets Buy America.
- GM closed their chassis plant thru the end of the year. Our builder, ElDorado has Ford chassis.
- Starcraft, Auto Spot's bus builder, has shut down indefinitely. ElDorado is open.

If we got a contact for those 10 buses next week, we could deliver them later this year.

We will email a proposal to you today for this new request today. Can we get a contact this week?

Thank you.

Sent from my iPhone

On Apr 14, 2020, at 7:02 PM, Rally M. Pilipina <rally.pilipina@grta.guam.gov> wrote:

Mr. Soderholm,

We're sorry that we can't assist with your inquiry on our previous bid solicitation for the 10 buses. After our bid specification submission to GSA, Guam procurement regulation prohibits us from communicating with any vendors until the bid award.

Thanks,

Rally M. Pilipina
GRTA

On Tue, Apr 14, 2020 at 7:22 PM Erik Soderholm <erik@soderholmbus.com> wrote:
Rally: OK. Thank you.

We will check?

Would you please tell us why the GSA has not replied to our repeated phone calls & emails to award us the bid for 10 buses we were the low bidder on 6 months ago? If they had awarded us the bid, you would have those buses now?

Thank you.

Sent from my iPhone

On Apr 14, 2020, at 4:16 PM, Rally M. Pilipina
<rally.pilipina@grta.guam.gov> wrote:

Mr. Soderholm,

Recently, FTA notified GRTA that the CARES Act grant funding is available for COVID-19.

Accordingly, GRTA requests marketing research information for 10 (ten) 14-passenger ADA-compliant cutaway buses, that will be purchased through emergency procurement. With emergency procurement, the local General Services Agency (GSA) requires 45 (forty-five) days or less delivery period.

GRTA would like to know if your company would be able to meet the subject GSA requirement.

Your immediate response to this inquiry would be greatly appreciated.

--

Si Yu'os Ma'ase,

Rally M. Pilipina, MBA
Chief Planner
Guam Regional Transit Authority
P. O. Box 2896
Hagatna, Guam 96932
Tel.: 671 300 7261 | Fax: 671 475 4600

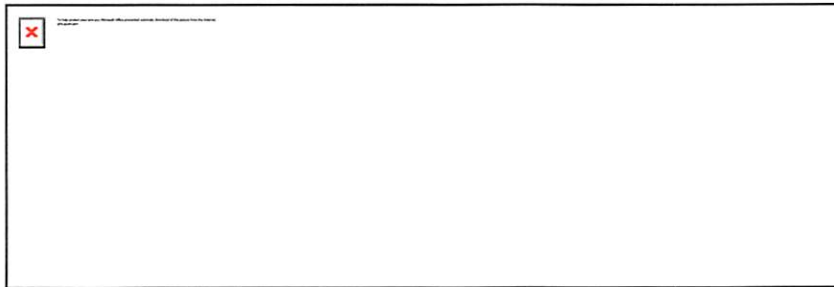

CONFIDENTIALITY STATEMENT: This message is from Guam Regional Transit Authority and contains information that is privileged and is solely for the use of the intended recipient. If you are not the intended recipient, any review, disclosure, copying, distribution, or use of the contents of this message is strictly prohibited. If you have received this transmission in error, please destroy it immediately.

--

Si Yu'os Ma'ase,

Rally M. Pilipina, MBA
Chief Planner
Guam Regional Transit Authority
P. O. Box 2896
Hagatna, Guam 96932
Tel.: 671 300 7261 | Fax: 671 475 4600

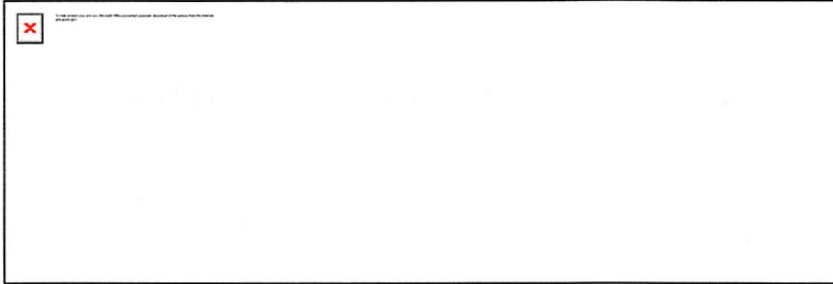

CONFIDENTIALITY STATEMENT: *This message is from Guam Regional Transit Authority and contains information that is privileged and is solely for the use of the intended recipient. If you are not the intended recipient, any review, disclosure, copying, distribution, or use of the contents of this message is strictly prohibited. If you have received this transmission in error, please destroy it immediately.*

Erik Soderholm

From: Erik Soderholm <erik@soderholmbus.com> on behalf of Erik Soderholm
Sent: Sunday, April 12, 2020 4:43 PM
To: christine.tedtaotao@gsadoa.guam.gov
Cc: Anita Cruz; robert.kono@gsa.guam.gov; Charlie Reynolds; Bruce Kloppenburg; Denise Soderholm; Gustaf Soderholm; Jessica Scheuring; Cel Babauta
Subject: GRTA 10 bus bid?

Christine: Would you please give us an update on the GRTA 10 bus bid? We would like to note:

- We were the low bidder in November on bid opening at \$4,500 under the other bidder, Auto Spot, per bus.
- We met all the bid terms based on the completed bid sheet.
- The GMC chassis that Auto Spot bid no longer meets the federal FTA requirement of 70% U.S. domestic content of Buy America. The Ford E-450 chassis we bid & are buying thru Triple J Motors, to get warranty in Guam, continues to meet Buy America.
- Starcraft Bus, the bus builder Auto Spot bid, has shut down indefinitely. ElDorado, our bus builder remains open building buses.
- GM has closed their GMC chassis plant that Auto Spot bid thru the end of the year.
- We have now been waiting for going on 6 months for a low bid we won?
- Isn't the GRTA transit bus operation an essential operation during this COVID-19 pandemic?
- We can deliver the 10 buses later this year to GRTA if we get a contract in the next few weeks? Although ElDorado Bus is open & building buses, and has Ford chassis, many component suppliers are closing, and if GSA continues to stall in giving us our lawful contract, eventually we won't be able to produce the buses until later this year?
- GRTA has an old bus fleet and needs new buses. Under normal circumstances before the COVID-19 pandemic we should have been issued this contract? Now under the Governor Leon Guerrero's emergency proclamation, we should get our contract ASAP to assure the essential GRTA bus service continues?

We would appreciate a reply?

Aloha.

Sent from my iPhone

Erik Soderholm

From: Erik Soderholm <erik@soderholmbus.com> on behalf of Erik Soderholm
Sent: Monday, March 16, 2020 10:42 AM
To: Christine Tedtaotao
Cc: Anita Cruz; Denise Soderholm; Gustaf Soderholm; Jessica Scheuring; Charlie Reynolds; Cel Babauta
Subject: Fwd: Buy America 03-09-2020
Attachments: image001.png; Untitled attachment 00475.htm; Buy America 03-09-2020.pdf; Untitled attachment 00478.htm

Christine: FYI. Please see attached. The Chevy chassis Auto Spot bid with a Starcraft body does not have enough content to meet the new 70% Buy America requirement. Starcraft sent out a similar letter to their dealers. Only the Ford E-450 chassis m we bid the ElDorado body meets Buy America.

Thus Guam can not meet Buy America with the Starcraft bus body on a Chevy chassis from Auto Spot, and get FTA funding.

Please email us the bid award letter that we were the lowest responsive bidder 4 months ago?

Thank you.

Sent from my iPhone

Begin forwarded message:

From: Jennie Graham <jennie.graham@revbusgroup.com>
Date: March 9, 2020 at 6:26:38 AM HST
Subject: Buy America 03-09-2020

Erik Soderholm

From: Erik Soderholm <erik@soderholm.com> on behalf of Erik Soderholm
Sent: Tuesday, February 25, 2020 4:41 AM
To: robert.kono@gsa.guam.gov
Cc: Claudia Acfalle; Denise Soderholm; Gus Soderholm; Jessica Scheuring; Charlie Reynolds; Helen Kusunoki; Anita Cruz; Christine Tedtaotao
Subject: Re: IFB GSA-055-19

Robert: Would you please give us an update on the status of our low responsive bid that was opened in November?

Thank you.

Sent from my iPhone

On Jan 2, 2020, at 3:08 PM, Christine Tedtaotao <Christine.Tedtaotao@gsadoa.guam.gov> wrote:

Buenas yan Hafa Adai Erik,

I apologize for not getting back to you asap. Erik, before I sent out Bid Status Notices, I need clarification on:

Page 48 of 74 Specifications:

Wheelchair lift, specification required lift located on curbside beside front entrance forward facing.

As per Bidding On / Remarks : Soderholm indicated per spec.

Are you able to point that out on one of the brochures that were submitted which I attached. Your assistance is greatly appreciated.

Thank you

Christine M. Tedtaotao
Buyer II
General Services Agency
Department of Administration
Phone No. 671-475-1705
Email: christine.tedtaotao@gsadoa.guam.gov
gsaprocurement@gsadoa.guam.gov
Web Site: www.gsa.doa.guam.gov
<image001.png>

ማህተብገላገሎታችን ግልጽግልጽ: This email and any files transmitted with it may be legally privileged and confidential and is intended solely for the use of the individual or entity named above. If you are not the intended recipient, you are hereby notified that any review, dissemination or copying of this email, or taking any action in reliance on the contents of this information is strictly prohibited. If you received this transmission in error, please notify us immediately by e-mail or telephone to arrange for the return of this email and any files to us or to verify it has been deleted from your system.

From: Erik Soderholm <erik@soderholmbus.com>

Sent: Thursday, January 2, 2020 10:03 AM

To: Christine Tedtaotao <Christine.Tedtaotao@gsadoa.guam.gov>

Cc: gsaprocurment <gsaprocurment@gsadoa.guam.gov>; Claudia Acfalle <Claudia.Acfalle@gsadoa.guam.gov>; Denise Soderholm <denise@soderholmbus.com>; Gus Soderholm <gus@soderholmbus.com>; Jessica Scheuring <jessica@soderholmbus.com>; Charlie Reynolds <fleetsales@triplejguam.com>; Helen Kusunoki <hkusunoki@triplejguam.com>; Celestin Babauta <celestin.babauta@grta.guam.gov>

Subject: Re: IFB GSA-055-19

Christine: Would you please follow up today on our request when we are getting a Notice of Award for the bus bid below that we were the lowest responsive bidder on 11/15/19?

Thank you.

Sent from my iPhone

On Dec 13, 2019, at 12:02 PM, Erik Soderholm <erik@soderholmbus.com> wrote:

Christine: We would like to follow up on the Letter of Award for IFB GSA-055-19 that was opened on 11/15/19 that we were the low bidder?

Aloha

R. Erik Soderholm
Vice President
Soderholm Sales & Leasing, Inc.
2044 Dillingham Blvd. Honolulu, HI 96819
Mailing address: P.O. Box 19010 Honolulu, HI 96817
808-834-1417 Fax 808-834-1070
erik@soderholmbus.com www.soderholmbus.com

This message and any attachments contain confidential information and is the property of Soderholm Sales and Leasing, Inc. and/or Soderholm Mobility, Inc.. If you are not the intended recipient (or authorized to receive for the recipient) and received this message in error; any use, distribution or disclosure is strictly prohibited. Please contact the sender by reply e-mail and delete all copies of this message from your computer system.

<GSA-055-19 SPECS APPROVAL.pdf>

Erik Soderholm

From: Erik Soderholm <erik@soderholmbus.com> on behalf of Erik Soderholm
Sent: Saturday, January 04, 2020 12:28 AM
To: Christine Tedtaotao
Cc: gsaprourement@gsadoa.guam.gov; Claudia Acfalle; Denise Soderholm; Gustaf Soderholm; Jessica Scheuring; Charlie Reynolds; Helen Kusunoki; Gene Arnold
Subject: Fwd: [EXTERNAL] Re: IFB GSA-055-19 lift location
Attachments: 2408-GA02-Model.pdf; Untitled attachment 00575.htm

Christine: Per your request for clarification, please find attached an alternative floor plan for your review. We would like to note;

- 1) This floor plan shows the wheelchair lift also on the curbside but now just rear of the entry door.
- 2) The specifications are confusing because as you stated in your request for clarification they called for "...forward facing"? There is no such wheelchair lift that is forward facing? Wheelchair lifts are either installed curbside or rear facing? This could be referring to the position of the wheelchair tiedown locations as that is the section it was in? But if so, then the wheelchair lift location should have been in the wheelchair lift section? The forward facing description was then a run on sentence, confusing and needed clarification from the winning bidder from GSA as you are asking for.
- 3) There is no cost difference in providing a curbside wheelchair lift on the curbside front or the rear. There also is no FMVSS or ADA government regulation mandate either way. It's purely a preference.
- 4) We can provide additional floor plans moving the seats & wheelchair positions around. This is a normal process after winning a bid to choose the final floor plan. The floor plan submitted was just a starting point. We make adjustment to bid floor plans often.
- 5) This process would normally be handled in a preproduction meeting after we receive the contract? This is how it's done across the U.S. mainland & in Hawaii with all the transit agencies including the City & County of Honolulu/Oahu Transit Services (OTS)/Handi-Van, County of Kauai, County of Maui, County of Hawaii & the Daniel K. Inouye International Airport/Wiki Wiki. Many of the bus build specifications are routinely clarified during the preproduction meeting/process to meet the requests of the transit agency. These are normally done for no cost change.
- 6) We would be pleased to have a preproduction meeting in Guam with GSA/GRTA. Gus, Nick, our Service Manager, and are are coming to Guam in March for the delivery & training of buses to Lam Lam with Triple J. We would could schedule a preproduction meeting?

Would you now please email us the Notice of Award for the bid we were the lowest responsive bidder for 7 weeks ago?

Christine, thank you for your continued assistance. Please call or email us any questions?

<GSA-055-19 SPECS APPROVAL.pdf>

Erik Soderholm

From: Erik Soderholm <erik@soderholmbus.com> on behalf of Erik Soderholm
Sent: Thursday, January 02, 2020 7:30 PM
To: Christine Tedtaotao
Cc: robert.kono@gsa.guam.gov; Claudia Acfalle; Denise Soderholm; Gus Soderholm; Jessica Scheuring; Charlie Reynolds; Helen Kusunoki; Gene Arnold
Subject: Re: IFB GSA-055-19

Christine: We said "per spec" which means we will meet the bid. The brochure we provided is a generic brochure that doesn't necessary meet exactly each bid. We will provide the wheelchair lift forward of the rear axle & rear of the entry door, per the bid specifications. The liability & responsibility is on us to provide the buses per the bid.

We have been waiting now for going on 7 weeks from the bid opening on 11/15/19. Our bid met all the bid criteria per the completed bid form from GSA. We were the lowest responsive bidder.

Thank you letting us clarify your questions.

Would you tell us now when we get the Notice of Award?

Thank you.

Sent from my iPhone

On Jan 2, 2020, at 5:08 PM, Christine Tedtaotao <Christine.Tedtaotao@gsadoa.guam.gov> wrote:

Buenas yan Hafa Adai Erik,

I apologize for not getting back to you asap. Erik, before I sent out Bid Status Notices, I need clarification on:

Page 48 of 74 Specifications:

Wheelchair lift, specification required lift located on curbside beside front entrance forward facing.

As per Bidding On / Remarks : Soderholm indicated per spec.

Are you able to point that out on one of the brochures that were submitted which I attached. Your assistance is greatly appreciated.

Thank you

Christine M. Tedtaotao
Buyer II
General Services Agency
Department of Administration
Phone No. 671-475-1705
Email: christine.tedtaotao@gsadoa.guam.gov
gsaprocurment@gsadoa.guam.gov
Web Site: www.gsa.doa.guam.gov
<image001.png>

ማሳሰቢያ: This email and any files transmitted with it may be legally privileged and confidential and is intended solely for the use of the individual or entity named above. If you are not the intended recipient, you are hereby notified that any review, dissemination or copying of this email, or taking any action in reliance on the contents of this information is strictly prohibited. If you received this transmission in error, please notify us immediately by e-mail or telephone to arrange for the return of this email and any files to us or to verify it has been deleted from your system.

From: Erik Soderholm <erik@soderholmbus.com>
Sent: Thursday, January 2, 2020 10:03 AM
To: Christine Tedtaotao <Christine.Tedtaotao@gsadoa.guam.gov>
Cc: gsaprocurment <gsaprocurment@gsadoa.guam.gov>; Claudia Acfalle <Claudia.Acfalle@gsadoa.guam.gov>; Denise Soderholm <denise@soderholmbus.com>; Gus Soderholm <gus@soderholmbus.com>; Jessica Scheuring <jessica@soderholmbus.com>; Charlie Reynolds <fleetsales@triplejguam.com>; Helen Kusunoki <hkusunoki@triplejguam.com>; Celestin Babauta <celestin.babauta@grta.guam.gov>
Subject: Re: IFB GSA-055-19

Christine: Would you please follow up today on our request when we are getting a Notice of Award for the bus bid below that we were the lowest responsive bidder on 11/15/19?

Thank you.

Sent from my iPhone

On Dec 13, 2019, at 12:02 PM, Erik Soderholm <erik@soderholmbus.com> wrote:

Christine: We would like to follow up on the Letter of Award for IFB GSA-055-19 that was opened on 11/15/19 that we were the low bidder?

Aloha

R. Erik Soderholm
Vice President
Soderholm Sales & Leasing, Inc.
2044 Dillingham Blvd. Honolulu, HI 96819
Mailing address: P.O. Box 19010 Honolulu, HI 96817
808-834-1417 Fax 808-834-1070
erik@soderholmbus.com www.soderholmbus.com

This message and any attachments contain confidential information and is the property of Soderholm Sales and Leasing, Inc. and/or Soderholm Mobility, Inc.. If you are not the intended recipient (or authorized to receive for the recipient) and received this message in error; any use, distribution or disclosure is strictly prohibited. Please contact the sender by reply e-mail and delete all copies of this message from your computer system.

Erik Soderholm

From: Erik Soderholm <erik@soderholmbus.com> on behalf of Erik Soderholm
Sent: Saturday, November 23, 2019 1:12 PM
To: Christine Tedaotao
Cc: Cel Babauta; Denise Soderholm; Gustaf Soderholm; Jessica Scheuring; Charlie Reynolds; Helen Flores Kusunoki
Subject: Bid contract?

Christine: Would you please send us the contract for the 10 bus bid we won a couple of weeks ago? Can you email it to us?

Thank you.

Sent from my iPhone