

CABOT MANTANONA LLP
 Rebecca J. Wrightson, Esq.
 929 South Marine Corps Dr., Ste. 200
 Tamuning, Guam 96913
 Telephone: (671) 646-2001
 Facsimile: (671) 646-0777
 Email: rw@cmlaw.us | as@cmlaw.us

Attorney for Purchasing Agency Guam Community College

RECEIVED
 OFFICE OF PUBLIC ACCOUNTABILITY
 PROCUREMENT APPEALS
 DATE: 11/5/21
 TIME: 9:05 AM EPM BY: [Signature]
 FILE NO OPA-PA: 21-013

**BEFORE THE PUBLIC AUDITOR
 PROCUREMENT APPEALS
 TERRITORY OF GUAM**

In the Matter of)	Appeal No. OPA-PA-21-013
)	
JJ Global Services,)	PROCUREMENT RECORD
)	
Appellant,)	VOLUME 1
)	
and)	
)	
Guam Community College)	
)	
Purchasing Agency.)	
)	

Purchasing Agency Guam Community College, by and through its attorney Cabot Mantanona LLP, respectfully submits Volume 1 of its Procurement Record for the above noted appeal.

Volume 1 of the Procurement Record hereby submitted contains pages numbered:

GCC PR0001 - 0217

- Tab 1. Certification of Completed Procurement Record
- Tab 2. Published notice in the newspaper of general circulation
- Tab 3. Procurement package ("IFB") issued to bidders
- Tab 4. Log of distribution of procurement package
- Tab 5. Minutes of pre-submission conferences; Log of attendees of pre-submission conferences

- Tab 6. Written questions from bidders; Written answers
- Tab 7. Log of bids received; Bid opening documents
- Tab 8. Bids received

Respectfully submitted November 5, 2021.

CABOT MANTANONA LLP
Attorneys for Purchasing Agency
Guam Community College

By:

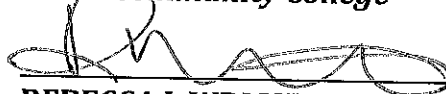
REBECCA J. WRIGHTSON

Procurement Appeal No. OPA-PA-21-013

Procurement Record

Tab 1

CERTIFICATION of COMPLETED PROCUREMENT RECORD

Instructions: After ascertaining the statement's accuracy and truthfulness, the agency's procurement officer (director or head of agency) must sign the Certification below to indicate that the agency has kept a complete procurement record of all documents required by law. The checklist below is provided to ensure that the record is complete, and must be filled out by the procurement officer or administrator. The checklist is comprised of every item that is required by law for an invitation for bid (IFB) or a request for proposal (RFP), and therefore every item, except as noted below, must be checked for the resulting contract to be considered legally sufficient. Please assemble the procurement record in the order stated below and place it in a three-ring binder, with visible tabs for each of the items below appearing in numerical order.

IFB/RFP No: G01-FB-21-009 Contractor: Replacement of Building 900 Metal Awning Structure

- 1. Published notice in newspaper of general circulation Awning Structure
- 2. Procurement package (IFB or RFP) issued to bidders or offerors
- 3. Log of distribution of procurement package
- 4. Amendments to IFB or RFP, if any were issued (NONE)
- 5. Logs of distribution of amendments to IFB or RFP, but only if amendments were issued (NONE)
- 6. Minutes or summary of pre-submission conferences, but only if conferences were held
- 7. Logs of attendees of pre-submission conferences, but only if conferences were held
- 8. Written questions from bidders or offerors, but only if any questions were received
- 9. Written answers, but only if any questions were received
- 10. Proof that written answers were provided to all potential bidders or offerors, but only if any questions were received
- 11. Log of bids or registry of proposals received
- 12. Each bid or proposal received
- 13. Evaluation of proposals or analysis of bids (bids are not required by law to be analyzed, but may be)
- 14. Tabulation of evaluations or analysis (tabulations are not required by law but recommended)
- 15. Letters to bidders concerning outcome of bid; for offerors, letters informing them of ranking and letter to best qualified offeror inviting negotiations (WA-AWARD)
- 16. Memorandum of evaluations and negotiations (only required for RFP's)
- 17. Notice of intent to award
- 18. Any and all communications from or to anyone concerning any part of IFB or RFP
- 19. Contract, including all draft versions Purchase Order/contract (copy)
- 20. Bid protests, if any, and responses thereto original contract w/ JG Global
(letter from JG Global dated 8/24/21) 8/24/21
- 21. Any determination required by law as may fit the circumstances

CERTIFICATION: Pursuant to 5 G.C.A. §6250, I hereby certify under penalty of perjury that I am the procurement officer responsible for administering the solicitation of the acquisition referenced above, and that I have caused to be prepared and now maintain a full and complete record of the procurement as required by law.

Signature: Joleen M. Evangelista
 Print Name: Joleen M. Evangelista Date: 10/13/2021

F

Procurement Appeal No. OPA-PA-21-013

Procurement Record
Tab 2



BID INVITATION

Bid No: GCC-FB-21-009

For: Replacement of Building 900 Metal Awning Structure

Pre-Bid Conference Date (Mandatory) & Site Visit: 10:00 a.m., Wednesday, May 19, 2021
GCC Technology Center, Room 1107
1st Floor, (Building 1000)

Bid Submission: 10:00 a.m., Thursday, June 3, 2021
GCC Materials Management Office, Room 2105
1st Floor, (Building 2000, GCC Student Services & Administration Building)

Bid Opening Date: 10:15 a.m. Friday, June 3, 2021
GCC Technology Center, Room 1107
1st Floor, (Building 1000)

Place: Guam Community College Student Services & Administration Building

Interested bidders may purchase a bid packet at the Cashier's Office (Room 2119) located in the GCC Student Service & Administration Building, 1st floor, during the hours of 8:00 a.m. to 4:00 p.m., Monday thru Friday (excluding Government of Guam holidays). Interested bidders must purchase a bid packet and attend the Mandatory Pre-bid conference in order to submit a bid. A non-refundable fee of \$25.00 must be paid on or before the Mandatory Pre-bid conference date. Upon payment and issuance of a receipt, a bid packet must be picked up from the Materials Management Office, Room 2105 (1st floor). A PDF file of the bid packet is available upon request via email.

For additional information, please contact the Materials Management Office at 735-5542 or email: materialsmanagement@guamcc.edu.

/s/ MARY A.Y. OKADA, Ed.D.
President

This advertisement was paid with Guam Community College Funds.
GCC is an equal opportunity provider and employer.



BID INVITATION

Bid No: GCC-FB-21-009

Bid Description: Replacement of Building 900 Metal Awning Structure

**Pre-Bid Conference
Date (Mandatory)
& Site Visit:** 10:00 a.m., Wednesday, May 19, 2021
GCC Technology Center, Room 1107
1st floor, (Building 1000)

Bid Submission: 10:00 a.m., Thursday, June 3, 2021
GCC Materials Management Office, Room 2105
1st Floor, (Building 2000, GCC Student Services & Administration
Building)

Bid Opening Date: 10:15 a.m., Thursday, June 3, 2021
GCC Technology Center, Room 1107
1st Floor, (Building 1000)

Place: Guam Community College Student Services & Administration Building

Interested bidders may purchase a bid packet at the Cashier's Office (Room 2119) located in the GCC Student Service & Administration Building, 1st floor, during the hours of 8:00 a.m. to 4:00 p.m., Monday thru Friday (excluding Government of Guam holidays). Interested bidders must purchase a bid packet and attend the Mandatory Pre-bid conference in order to submit a bid. A non-refundable fee of \$25.00 must be paid on or before the Mandatory Pre-Bid Conference date. Upon payment and issuance of a receipt, a bid packet must be picked up from the Materials Management Office, Room 2105 (1st floor). A PDF file of the bid packet is available upon request via email.

For additional information, please contact the Materials Management Office at 735-5542 or email: materialsmanagement@guamcc.edu.

This advertisement was paid with Guam Community College Funds.
GCC is an equal opportunity provider and employer.

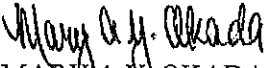
MARY A. Y. OKADA, Ed.D.
President *RY*



Patricia Palacios <patricia.palacios@guamcc.edu>

Bid Advertisement

2 messages

Patricia Palacios <patricia.palacios@guamcc.edu>

Tue, May 11, 2021 at 3:52 PM

To: The Post Admin <admin@postguam.com>, The Post Advertising <advertise@postguam.com>, Guam Community College <materialsmanagement@guamcc.edu>

Hi Mar,

Attached is the Bid Invitation for GCC-FB-21-009 - Replacement of Building 900 Metal Awning Structure. This is for a 2x5 B/W, one day ad only to be issued out on Thursday, May 13, 2021. This ad will be charged to a new purchase order, this will be forthcoming, the PO is in route for approval. Once approved, I will email you the purchase order.

Please acknowledge receipt of this email.

Thank You,
Patricia U. Palacios
MMO/GCC

Bid Advertisement - GCC-FB-21-009.pdf
26K

The Post Advertising <advertise@postguam.com>

Tue, May 11, 2021 at 3:59 PM

To: Patricia Palacios <patricia.palacios@guamcc.edu>, The Post Admin <admin@postguam.com>, Guam Community College <materialsmanagement@guamcc.edu>

Hi, Ms. Pat

Will prepare proof and invoice.

Cheers,

MAR SANTOS

Ad Coordinator

T: 649-1924 | C: 480-5033 | F: 648-2007

E: advertise@postguam.com

THE GUAM
DAILY **POST**TM

Follow us on

...

Need To Build (NTB) Ad Materials are due by 11AM two (2) days prior to the 1st publication date(s).

A \$75.00 late charge fee will be applied for (1) day prior to publication requests between 8-11am.

Camera Ready (CR) Ads are due by 11AM one (1) day prior to the publication date.

GCC PR0004



Congratulations

KEEP INFORMED ON YOUR
JOURNEY TO YOUR CAREER

A SPECIAL OFFER FOR NEW SUBSCRIBERS.

Sign up for a home delivery or digital subscription and get 15% off the cost of a regular subscription.
Valid until June 1, 2021.

Fill out this form and email it to subscribe@postguam.com or call 647-1926.

CODE: PROM0201

**Offer applies to six or 12-month subscriptions.*

[Quoted text hidden]



E-mail administered by Guam Community College



Patricia Palacios <patricia.palacios@guamcc.edu>

Proof & Invoice

2 messages

xerox.scan2@guamcc.edu <xerox.scan2@guamcc.edu>
Reply-To: xerox.scan@guamcc.edu
To: "Palacios, Patricia U." <patricia.palacios@guamcc.edu>

Wed, May 12, 2021 at 11:17 AM

Please open the attached document. It was scanned and sent to you using a Xerox Multifunction Printer.

Attachment File Type: pdf, Multi-Page

Multifunction Printer Location: RM 2111
Device Name: Admin WC5890

For more information on Xerox products and solutions, please visit <http://www.xerox.com>

--

E-mail administered by Guam Community College

 001.pdf
93K

Patricia Palacios <patricia.palacios@guamcc.edu>

Wed, May 12, 2021 at 11:22 AM

To: The Post Admin <admin@postguam.com>, The Post Advertising <advertise@postguam.com>
Cc: Guam Community College <materialsmanagement@guamcc.edu>

Hi Mar,

Attached are the proof with corrections & the approved invoice.

Thank You,
Patty

[Quoted text hidden]

 001.pdf
93K

GCC PR0006

Advertiser **GCC** AO# **71905** Size **2x4** Color **BW** Run Date(s) **5/13**

1st Proof **5/11** 2nd Proof **5/12** 3rd Proof **5/12** 4th Proof **5/12** LAST PROOF **5/12**

GUAM COMMUNITY COLLEGE

BID INVITATION

Bid No: GCC-FB-21-009

For: Replacement of Building 900 Metal Awning Structure

Pre-Bid Conference Date (Mandatory) & Site Visit: 10:00 a.m., Wednesday, May 19, 2021
GCC Technology Center, Room 1107
1st Floor, (Building 1000)

Bid Submission: 10:00 a.m., Thursday, June 3, 2021
GCC Materials Management Office, Room 2105
1st Floor, (Building 2000, GCC Student Services & Administration Building)

Bid Opening Date: 10:15 a.m. Friday, June 3, 2021
GCC Technology Center, Room 1107
1st Floor, (Building 1000)

Place: Guam Community College Student Services & Administration Building

Interested bidders may purchase a bid packet at the Cashier's Office (Room 2119) located in the GCC Student Service & Administration Building, 1st floor, during the hours of 8:00 a.m. to 4:00 p.m., Monday thru Friday (excluding Government of Guam holidays). Interested bidders must purchase a bid packet and attend the Mandatory Pre-bid conference in order to submit a bid. A non-refundable fee of \$25.00 must be paid on or before the Mandatory Pre-bid conference date. Upon payment and issuance of a receipt, a bid packet must be picked up from the Materials Management Office, Room 2105 (1st floor). A PDF file of the bid packet is available upon request via email.

For additional information, please contact the Materials Management Office at 736-6542 or email: materialsmanagement@guamcc.edu.

/s/ MARY A. Y. OKADA, Ed.D.
President

This advertisement was paid with Guam Community College Funds.
GCC is an equal opportunity provider and employer.

Please review your ad carefully and indicate any corrections or changes. Email / Fax approval or changes to The Guam Daily Post at advertise@postguam.com / (671) 648-2007. If you have questions concerning this proof, please call (671) 649-1924.

APPROVED AS IS APPROVED WITH CHANGES INDICATED PLEASE SEND ANOTHER PROOF

Approval Signature *Mellen M. Gangelista* Date 5/12/21

If we do not receive the proof back by 4:00 pm the day of approval, we will assume the ad is acceptable. Thank you for your assistance.

NEED TO BUILD (NTB) AD MATERIALS ARE DUE BY 11:00 AM TWO (2) DAYS PRIOR TO THE PUBLICATION DATE. \$75.00 LATE CHARGE FEE WILL BE APPLIED FOR (1) DAY PRIOR TO PUBLICATION REQUESTS BETWEEN 8:00 AM - 11:00 AM. CANCELLATION REQUESTS WILL NEED TO BE MADE TWO (2) DAYS PRIOR TO PUBLICATION DAY TO PREVENT THE CANCELLATION FEE OF \$75.00 BEING APPLIED TO YOUR REQUEST.

THE GUAM DAILY POST

GCC PR0007



BID INVITATION

Bid No: GCC-FB-21-009

For: Replacement of Building 900 Metal Awning Structure

**Pre-Bid Conference Date
(Mandatory) & Site Visit:** 10:00 a.m., Wednesday, May 19, 2021
GCC Technology Center, Room 1107
1st Floor, (Building 1000)

Bid Submission: 10:00 a.m., Thursday, June 3, 2021
GCC Materials Management Office, Room 2105
1st Floor, (Building 2000, GCC Student Services &
Administration Building)

Bid Opening Date: 10:15 a.m. Friday, June 3, 2021
GCC Technology Center, Room 1107
1st Floor, (Building 1000)

Place: Guam Community College Student Services &
Administration Building

Interested bidders may purchase a bid packet at the Cashier's Office (Room 2119) located in the GCC Student Service & Administration Building, 1st floor, during the hours of 8:00 a.m. to 4:00 p.m., Monday thru Friday (excluding Government of Guam holidays). Interested bidders must purchase a bid packet and attend the Mandatory Pre-bid conference in order to submit a bid. A non-refundable fee of \$25.00 must be paid on or before the Pre-bid conference date. Upon payment and issuance of a receipt, a bid packet must be picked up from the Materials Management Office, Room 2105 (1st floor). A PDF file of the bid packet is available upon request via email.

For additional information, please contact the Materials Management Office at 735-5542 or email: materialsmanagement@guamcc.edu.

L Mandatory

/s/ MARY A.Y. OKADA, Ed.D.
President

This advertisement was paid with Guam Community College Funds.
GCC is an equal opportunity provider and employer.

GCC PR0008

Advertiser **GCC** AO# **71905** Size **2x4** Color **BW** Run Date(s) **5/13**

1st Proof **5/11** 2nd Proof **5/12** 3rd Proof **5/12** 4th Proof **5/12** LAST PROOF _____



BID INVITATION

Bid No: GCC-FB-21-009

For: Replacement of Building 900 Metal Awning Structure

Pre-Bid Conference Date (Mandatory) & Site Visit: 10:00 a.m., Wednesday, May 19, 2021
GCC Technology Center, Room 1107
1st Floor, (Building 1000)

Bid Submission: 10:00 a.m., Thursday, June 3, 2021
GCC Materials Management Office, Room 2105
1st Floor, (Building 2000, GCC Student Services & Administration Building)

Bid Opening Date: 10:15 a.m. Friday, June 3, 2021
GCC Technology Center, Room 1107
1st Floor, (Building 1000)

Place: Guam Community College Student Services & Administration Building

Interested bidders may purchase a bid packet at the Cashier's Office (Room 2119) located in the GCC Student Service & Administration Building, 1st floor, during the hours of 8:00 a.m. to 4:00 p.m., Monday thru Friday (excluding Government of Guam holidays). Interested bidders must purchase a bid packet and attend the Mandatory Pre-bid conference in order to submit a bid. A non-refundable fee of \$25.00 must be paid on or before the Pre-bid conference date. Upon payment and issuance of a receipt, a bid packet must be picked up from the Materials Management Office, Room 2105 (1st floor). A PDF file of the bid packet is available upon request via email.

Mandatory

For additional information, please contact the Materials Management Office at 735-5542 or email: materialsmanagement@guamcc.edu.

/s/ MARY A.Y. OKADA, Ed.D.
President
This advertisement was paid with Guam Community College Funds.
GCC is an equal opportunity provider and employer.

Please review your ad carefully and indicate any corrections or changes. Email / Fax approval or changes to The Guam Daily Post at advertise@postguam.com / (671) 648-2007. If you have questions concerning this proof, please call (671) 649-1924.

no

APPROVED AS IS APPROVED WITH CHANGES INDICATED PLEASE SEND ANOTHER PROOF

Approval Signature *Mary A.Y. Okada* Date 5/12/21

If we do not receive the proof back by 4:00 pm the day of approval, we will assume the ad is acceptable. Thank you for your assistance.

NEED TO BUILD (NTB) AD MATERIALS ARE DUE BY 11:00 AM TWO (2) DAYS PRIOR TO THE PUBLICATIONS DATE. \$75.00 LATE CHARGE FEE WILL BE APPLIED FOR (1) DAY PRIOR TO PUBLICATION REQUESTS BETWEEN 6:00 AM - 11:00 AM. CANCELLATION REQUESTS WILL NEED TO BE MADE TWO (2) DAYS PRIOR TO PUBLICATION DAY TO PREVENT THE CANCELLATION FEE OF \$75.00 BEING APPLIED TO YOUR REQUEST.



GCC PR0009



BID INVITATION

Bid No: ^{FB} GCC-JFB-21-009

For: Replacement of Building 900 Metal Awning Structure

Pre-Bid Conference Date (Mandatory) & Site Visit: 10:00 a.m., Wednesday, May 19, 2021
GCC Technology Center, Room 1107
1st Floor, (Building 1000)

Bid Submission: ↑ *move up to align to 10:00 a.m.* 10:00 a.m., Thursday, June 3, 2021
GCC Materials Management Office, Room 2105
1st Floor, (Building 2000, GCC Student Services & Administration Building)

Bid Opening Date: ↑ *move up to align to 10:15 a.m.* 10:15 a.m. Friday, June 3, 2021
GCC Technology Center, Room 1107
1st Floor, (Building 1000)

Place: Guam Community College Student Services & Administration Building

Interested bidders may purchase a bid packet at the Cashier's Office (Room 2119) located in the GCC Student Service & Administration Building, 1st floor, during the hours of 8:00 a.m. to 4:00 p.m., Monday thru Friday (excluding Government of Guam holidays). Interested bidders must purchase a bid packet and attend the Mandatory Pre-bid conference in order to submit a bid. A non-refundable fee of \$25.00 must be paid on or before the Pre-bid conference date. Upon payment and issuance of a receipt, a bid packet ^{must} can be picked up from the Materials Management Office, Room 2105 (1st floor). A PDF file of the bid packet is available upon request via email.

For additional information, please contact the Materials Management Office at 735-5542 or email: materialsmanagement@guamcc.edu.

/s/ MARY A.Y. OKADA, Ed.D.
President

This advertisement was paid with Guam Community College Funds.
GCC is an equal opportunity provider and employer.

Advertiser **GCC** AO# **71905** Size **2X4** Color **BW** Run Date(s) **5/13**

1st Proof **5/11** 2nd Proof _____ 3rd Proof _____ 4th Proof _____ LAST PROOF _____

(space)
move down ←

Please see attached
Bid Invitation
on correct verbiage
for GCC-FB-21-009.

Thanks,
Patty

 GUAM COMMUNITY COLLEGE BID INVITATION	
Bid No:	GCC-FB-21-009
For:	Replacement of Building 900 Metal Awning Structure
Pre-Bid Conference Date (Mandatory) & Site Visit:	10:00 a.m. Tuesday, May 19, 2021 GCC Technology Center, Room 1107 1 st Floor (Building 1000)
Bid Submission:	10:00 a.m. Friday, June 3, 2021 GCC Materials Management Office, Room 2105 1 st Floor (Building 2000, GCC Student Services & Administration Building)
Bid Opening Date:	10:15 a.m. Friday, June 3, 2021 GCC Technology Center, Room 1107 1 st Floor, (Building 1000)
Place:	Guam Community College Student Services & Administration Building
<small>Interested vendors may purchase a bid packet at the Cashier's Office (Room 2119) located in the GCC Student Service & Administration Building, 1st floor, during the hours of 8:00 a.m. to 4:00 p.m., Monday thru Friday (excluding Government of Guam holidays). Upon payment and issuance of a receipt, a bid packet can be picked up from the Materials Management Office, Room 2105 (1st floor). A non-refundable fee of \$25.00 must be paid on or before the Pre-bid conference date. Interested bidders must purchase a bid packet and attend the Mandatory Pre-bid conference in order to submit a bid. A PDF file of the bid packet is available upon request via email. For additional information, please contact the Materials Management Office at 735-6542 or email: materialsmgmt@guamcc.edu.</small>	
/s/ MARY A.Y. OKADA, Ed.D. President This advertisement was paid with Guam Community College Funds. GCC is an equal opportunity provider and employer.	

Please review your ad carefully and indicate any corrections or changes. Email / Fax approval or changes to The Guam Daily Post at advertise@postguam.com / (671) 648-2007. If you have questions concerning this proof, please call (671) 649-1924.

APPROVED AS IS

APPROVED WITH CHANGES INDICATED

PLEASE SEND ANOTHER PROOF

Approval Signature _____

Jean M. Gangelist

Date _____

5/12/21

If we do not receive the proof back by 4:00 pm the day of approval, we will assume the ad is acceptable. Thank you for your assistance.

NEED TO BUILD (NYB) AD MATERIALS ARE DUE BY 11:00 AM TWO (2) DAYS PRIOR TO THE PUBLICATIONS DATE. \$75.00 LATE CHARGE FEE WILL BE APPLIED FOR (1) DAY PRIOR TO PUBLICATION REQUESTS BETWEEN 8:00 AM - 11:00 AM. CANCELLATION REQUESTS WILL NEED TO BE MADE TWO (2) DAYS PRIOR TO PUBLICATION DAY TO PREVENT THE CANCELLATION FEE OF \$75.00 BEING APPLIED TO YOUR REQUEST.

THE GUAM
DAILY POST

GCC PR0011



Patricia Palacios <patricia.palacios@guamcc.edu>

Final Proof

4 messages

xerox.scan2@guamcc.edu <xerox.scan2@guamcc.edu>
Reply-To: xerox.scan@guamcc.edu
To: "Palacios, Patricia U." <patricia.palacios@guamcc.edu>

Wed, May 12, 2021 at 4:18 PM

Please open the attached document. It was scanned and sent to you using a Xerox Multifunction Printer.

Attachment File Type: pdf, Multi-Page

Multifunction Printer Location: RM 2111
Device Name: Admin WC5890

For more information on Xerox products and solutions, please visit <http://www.xerox.com>

--

E-mail administered by Guam Community College

 Final Proof.pdf
32K

Patricia Palacios <patricia.palacios@guamcc.edu>
To: The Post Advertising <advertise@postguam.com>, The Post Admin <admin@postguam.com>

Wed, May 12, 2021 at 4:29 PM

Hi Mar,

Attached is the final proof for GCC-FB-21-009.
Please acknowledge receipt of this email.

Thanks,
Patty
[Quoted text hidden]

 Final Proof.pdf
32K

The Post Advertising <advertise@postguam.com>
To: Patricia Palacios <patricia.palacios@guamcc.edu>, The Post Admin <admin@postguam.com>

Wed, May 12, 2021 at 4:37 PM

Awesome!

Thank you, Ms. Patty 😊

Cheers,

GCC PR0012

MAR SANTOS
Ad Coordinator
T: 649-1924 | C: 480-5033 | F: 648-2007
E: advertise@postguam.com

THE GUAM DAILY POST™

Follow us on   

*Need To Build (NTB) Ad Materials are due by 11AM two (2) days prior to the 1st publication date(s).
A \$75.00 late charge fee will be applied for (1) day prior to publication requests between 8-11am.
Camera Ready (CR) Ads are due by 11AM one (1) day prior to the publication date.*

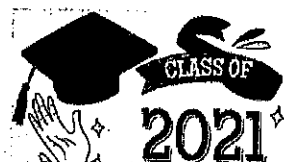

Congratulations

KEEP INFORMED ON YOUR
JOURNEY TO YOUR CAREER

A SPECIAL OFFER FOR NEW SUBSCRIBERS.

Sign up for a home delivery or digital subscription and get 15% off the cost of a regular subscription.
Valid until June 1, 2021.

Fill out this form and email it to subscribe@postguam.com or call 649-1924.

CODE: PROMO2021

**Offer applies to six or 12-month subscriptions.*

[Quoted text hidden]



E-mail administered by Guam Community College

Patricia Palacios <patricia.palacios@guamcc.edu>
To: The Post Advertising <advertise@postguam.com>
Cc: The Post Admin <admin@postguam.com>

Wed, May 12, 2021 at 4:41 PM

Thanks!

[Quoted text hidden]

GCC PR0013

Procurement Appeal No. OPA-PA-21-013

Procurement Record

Tab 3

GUAM COMMUNITY COLLEGE
BID INVITATION

Mary A.Y. Okada, Ed.D.
GCC PRESIDENT

GUAM COMMUNITY COLLEGE
P.O. BOX 23069 GMF, GUAM 96921
1 SESAME STR. MANGILAO, GUAM 96913

DATE ISSUED: May 13, 2021

BID INVITATION NO.: GCC-FB-21-009

INSTRUCTION: This BID shall be submitted in original, plus Two (2) copies, in a sealed envelope and delivered to the specified location below on or before (Time) 10:00 A.M., (Date) Thursday, June 03, 2021. The Bid shall be Publicly opened at 10:15 A.M. Bids submitted after the time and date specified above shall be rejected. See attached Solicitation Instructions and Conditions for details.

BID FOR:

Replacement of Building 900 Metal Awning Structure

SPECIFICATIONS:

See Attached Scope of Work

BID SUBMISSION LOCATION:

GUAM COMMUNITY COLLEGE

Materials Management Office

Room 2105 1st fl. Administration Bldg. 2000

Mandatory Pre-Bid Conference & Site Visit

10:00 am., Wednesday, May 19, 2021

GCC Technology Center Building 1000, Room 1107

BID OPENING LOCATION:

GCC Technology Center, Building 1000, Room 1107

REQUIRED DELIVERY DATE:

90 Calendar Days upon Receipt of the Purchase Order/Contract

SUBMISSION DEADLINE FOR QUESTIONS:

5:00 P.M., Thursday, May 20, 2021

DEADLINE FOR GCC RESPONSES:

5:00 P.M., Tuesday, May 25, 2021

ALL INQUIRIES REGARDING THIS BID MUST BE ADDRESSED TO: Procurement & Inventory Administrator, Materials Management Office

MATERIALS MANAGEMENT CONTACT INFORMATION: TELEPHONE: 735-5542/5540; FACSIMILE: 734-5238;

EMAIL: materialsmanagement@guamcc.edu; WEBSITE: www.guamcc.edu

NOTE TO BIDDERS:

This bid is subject to the attached General Terms and Conditions of the Invitation for Bids. The undersigned offers and agrees to furnish within the time specified, the articles and services at the price stated opposite otherwise specified by the bidder. The undersigned further agrees this bid will remain firm and irrevocable if accepted within _____ calendar days (60 calendar days unless a different period is inserted), from the date of the opening, to furnish any or all of the items which prices are quoted.

INDICATE WHETHER: INDIVIDUAL PARTNERSHIP CORPORATION

INCORPORATED IN:

NAME AND ADDRESS OF BIDDER:

SIGNATURE AND TITLE OF PERSON
AUTHORIZED TO SIGN THIS BID:

AWARD:

CONTRACT NO.:

AMOUNT:

DATE:

ACCEPTED AS TO ITEMS NUMBERED:

CONTRACTING OFFICER

GCC PRESIDENT

NAME AND ADDRESS OF CONTRACTOR:

SIGNATURE AND TITLE OF PERSON AUTHORIZED
TO SIGN THIS CONTRACT



Guam Community College
 PO Box 23069
 Barrigada, Guam 96921

Accountability • Impartiality • Competence • Openness • Value

INVITATION FOR BID (IFB) NO.: GCC-FB-21-009

DESCRIPTION: Replacement of Building 900 Metal Awning Structure

SPECIAL REMINDER TO PROSPECTIVE BIDDERS

Bidders are reminded to read the Sealed Bid Solicitation and Instructions, and General Terms and Conditions attached to the IFB to ascertain that all of the following requirements checked below are submitted in the bid envelope, original and two (2) copies, at the date and time for bid opening.

- BID GUARANTEE (15% OF BID AMOUNT) – May be in the form of;**
 - a. **Cashier’s Check or Certified Check**
 - b. **Letter of Credit** (must not expire no earlier than ninety (90) days from the date of submittal); or
 - c. **Surety Bond – Valid only if accompanied by:**
 - 1. Current Certificate of Authority issued by the Insurance Commissioner;
 - 2. Power of Attorney issued by the Surety to the Resident General Agent;
 - 3. Power of Attorney issued by two (2) major officers of the Surety to whoever is signing on their behalf.
- BROCHURES/DESCRIPTIVE LITERATURE/Technical Specifications:** To make it easier to evaluate, please tab and reference each item number (18a – 18e) and highlight each specification requirement and attach the descriptive literature/product brochure for each respective item number.
- Project Narrative:** Describing how the qualified contractor will address this project's Scope of Work
- CPM Chart** (Critical Path Method) to illustrate the Qualified Contractor's timeline to complete the project, within (Ninety) 90 consecutive calendar days upon receipt of a purchase order & inclusive of the building permit, process & material lead time.
- Conceptual Design:** Illustrating the size and design of the awning.
- AFFIDAVIT OF DISCLOSING OWNERSHIP AND COMMISSIONS – Must comply with the following requirements:**
 - a. A bidder intends to participate in a bid opening on October 15 and submits his/her bid on September 12, the affidavit dated September 10 is acceptable
 - b. If the affidavit is a copy, indicate the Bid No. and where it is filed
- NON-COLLUSION AFFIDAVIT, AFFIDAVIT re: GRATUITIES AND KICKBACKS, AFFIDAVIT re: ETHICAL STANDARDS AND AFFIDAVIT re: CONTINGENT FEES (must be notarized)**
- Declaration Re Compliance with U.S. DOL Wage Determination:** Please see instructions in U.S. DOL Form
- Acknowledgement receipts of pre-bid minutes and or addendums upon issuance from Materials Management Office
- Copy of current and valid Guam Contractors license (upon Issuance of Award)
- Non-Refundable fee of \$25.00 must be paid on or before the Mandatory Pre-Bid Conference & Site Visit date.
- Failure to comply with the requirements in the special reminder will be a basis for disqualification and rejection of the bid. This reminder must be signed and returned in the bid envelope together with the bid. Failure to comply with the above requirements will mean a disqualification and rejection of the bid. On this _____ day of _____, 2021, _____ acknowledge receipt of this special reminder to prospective bidders with the above referenced IFB.

 Bidder Representative's Signature

**GUAM COMMUNITY COLLEGE
SEALED BID SOLICITATION
INSTRUCTIONS**

This solicitation is issued subject to all the provisions of Guam Procurement Laws in 5 G.C.A. chapter 5, and 2 G.A.R., div4 (both are available online at: <http://www.guamcourts.org/CompilerofLaws/index.html>).

1. BID FORMS:

Each Bidder shall be provided with one (1) set of Solicitation forms. Additional copies may be provided by request.

2. PREPARATION OF BIDS:

- (a) Bidders are required to examine all drawings, specifications, schedules, and all other accompany instructions and documents.
- (b) Each bidder shall furnish the information required by the Solicitation. The bidder shall sign the Solicitation and print or type his/her name on the Schedule. Erasures or other changes must be initialed by the person signing the bid.. Bids signed by an agent are to be accompanied by evidence of his/her authority unless such evidence has been previously furnished to the issuing office.
- (c) Unit price for each unit offered shall be shown and such price shall include packing unless otherwise specified. A total shall be entered in the amount column of the Schedule for each item offered. In case of discrepancies between a unit price and the extended price, the unit price will be presumed to be correct.
- (d) Bids for supplies or services other than those specified will not be considered.
- (e) Bids must state a definite time for delivery of supplies or performance of services.
- (f) Time, if stated as a number of days, means calendar days and will include Saturdays, Sundays, and holidays. Time stated ending on a Saturday, Sunday or Government of Guam legal holiday will end at the close of the next business day.

3. EXPLANATION TO BIDDERS:

Any explanation desired by a bidder regarding the meaning or interpretation of the Solicitation, drawings, specifications, etc., must be submitted in writing and with sufficient time allowed for a written reply to reach all bidders before submission on their bids. Oral explanation or instructions given before the award of the contract will not be binding. Any information given to a prospective bidder concerning a Solicitation will be furnished to all prospective bidders in writing as an amendment to the Solicitation if such information is necessary for bidders in submitting bids on the Solicitation or if the lack of such information would be prejudicial to uniformed bidders.

4. ACKNOWLEDGEMENT OF AMENDMENTS TO SOLICITATIONS:

Receipt of an amendment to a Solicitation by a bidder must be acknowledged by signing an acknowledgement of receipt of the amendment. Such acknowledgement must be received prior to the hour and date specified for receipt of bids.

5. SUBMISSION OF BIDS:

(a) Bids and modifications thereof shall be enclosed in sealed envelopes and addressed to the office specified in the Solicitation. The bidder shall show the hour and date specified in the Solicitation for receipt, the Solicitation number, and the name and address of the bidder on the face of the envelope. The College will base the award only upon the information provided in the bid envelope, and facts available at the time of bid opening. Incomplete bids will be considered unresponsive and the Bid will be disqualified from receiving the award.

(b) Telegraphic bids will not be considered unless authorized by the Solicitation. However, bids may be modified or withdrawn by written or telegraphic notice, provided such notice is received prior to the hour and date specified for receipt (see paragraph 6 of these instructions).

(c) Samples of items, when required, must be submitted within the time specified, unless otherwise specified by the College, at no expense to the College. If not destroyed by testing, samples will be returned at bidder's request and expense, unless otherwise specified by the Solicitation.

(d) Samples or descriptive literature should not be submitted unless it is required on this Solicitation. Regardless of any attempt by a bidder to condition the bid, unsolicited samples or descriptive literature will not be examined or tested, and will not be deemed to vary any of the provisions of this Solicitation.

6. FAILURE TO SUBMIT BID:

If no bid is to be submitted, do not return the Solicitation unless otherwise specified. A letter or postcard shall be sent to the issuing office advising whether future Solicitations for the type of supplies or services covered by this Solicitation are desired. Failure of the recipient to bid, or to notify the issuing office that future Solicitations are desired, may result in removal of the name of such recipient from the mailing list for the type of supplies or services covered by the solicitation.

7. LATE BID, LATE WITHDRAWALS, AND LATE MODIFICATIONS:

(a) Definition: Any bid received after the time and date set for receipt of bids is late. Any withdrawal or modifications of a bid received after the time and date set for opening of bids at the place designated for opening is late.

(b) Treatment: No late bid, late modification, or late withdrawal will be considered unless received before contract award, and the modification, or withdrawal would have been timely but for the action or inaction of territorial personnel directly serving the procurement activity.

8. DISCOUNTS:

(a) Notwithstanding the fact that prompt payment discounts may be offered such offer will not be considered in evaluating bids for award unless otherwise specified in the Solicitation. However, offered discounts will be taken if payment is made within the discount period, even though not considered in the evaluation of bids. (b) In connection with any prompt payment discount offered, time will be computed from date of delivery and acceptance of the supplies to the destination as indicated in the purchase order contract. Pay is deemed to be made for the purpose of earning the discount on the date of mailing of the College check.

9. GOVERNMENT FURNISHED PROPERTY:

No material, labor or facilities will be furnished by the College unless otherwise provided for in the Solicitation.

10. SELLER'S INVOICES:

Invoices shall be prepared and submitted in quadruplicate (one copy shall be marked "original") unless otherwise specified. Invoices shall be "certified true and correct" and shall contain the Contract and Order Number, item numbers, description of supplies or services, sizes, quantities, unit prices, and extended total. Bill of lading number and weight of shipment will be shown for shipments made on Government bills of lading.

11. RECEIPT, OPENING AND RECORDING OF BIDS:

Bids and modifications shall be publicly opened in the presence of one or more witnesses, at the time, date, and place designated in the Invitation for Bids. The name of each bidder, the bid price, and such other information as is deemed appropriate by the Procurement Officer, shall be read aloud and recorded, or otherwise made available. The names and addresses of required witnesses shall be recorded at the opening. The opened bids shall be available for public inspection except to the extent the bidder designates trade secrets or other proprietary data to be confidential as set forth in accordance with Guam laws. Each page of confidential or proprietary information in the bid shall be labeled "confidential" or "proprietary". Material so designated shall accompany the bid and shall be readily separable from the bid in order to facilitate public inspection of the non-confidential portion of the bid. All non-confidential and non-proprietary information shall be publicly available at the time of bid opening

12. CONFIDENTIAL DATA:

The Procurement Officer shall examine the bids to determine the validity of any request for non-disclosure of trade secrets and other confidential or proprietary data identified in writing. If the parties do not agree as to the disclosure of the data, either party may file a protest according to Guam Procurement Law. The bids shall be opened to public inspection subject to any continuing prohibition on the disclosure of confidential data.

**GENERAL TERMS AND CONDITIONS
SEALED BID SOLICITATION AND AWARD
(Only items marked "X" are applicable to this bid).**

- (X)1. **AUTHORITY:**
This solicitation is issued subject to all the provisions of Guam Procurement Laws in 5 GCA Chapter 5, and 2 GAR, Div. 4 (both are available online at <http://www.guamcourts.org/CompilerofLaws/index.html>). Guam Procurement Law requires that all parties involved act in good faith.
- (X)2. **GENERAL INTENTION:**
It is the declared and acknowledged intention and meaning of these General Terms and Conditions for the bidder to provide Guam Community College with specified services or with materials, supplies or equipment completely assembled and ready for use.
- (X)3. **TAXES:**
Bidders are cautioned that they are subject to Guam Income Taxes as well as other taxes on Guam Transactions. Specified information on taxes may be obtained from the Director of Revenue and Taxation.
- (X)4. **LICENSING:**
Bidders are cautioned that the College will not consider for award any offer submitted by a bidder who has not complied with the Guam Licensing Law. Specific information on licenses may be obtained from the Director of Revenue and Taxation.
- ()5. **LOCAL PROCUREMENT PREFERENCE:**
All procurement of supplies and services will be made from among businesses licensed to do business in Guam in accordance with Guam Procurement Law.
- (X)6. **COMPLIANCE WITH SPECIFICATIONS AND OTHER SOLICITATION REQUIREMENTS:** Bidders shall comply with all specifications and other requirements of the Solicitation.
- (X)7. **"ALL OR NONE" BIDS:**
Unless otherwise allowed under this solicitation, "all or none" bids shall be deemed to be non-responsive. If the bid is so limited, the College shall not reject part of such proposal and award on the remainder. The whole bid must be rejected.
- (X)8. **INDEPENDENT PRICE DETERMINATION:**
The bidder, upon signing the Invitation to Bid, certifies that the prices in the bid were derived at without collusion, and acknowledge that collusion and anticompetitive practices are prohibited by law. Violations will be subject to Guam Procurement laws. Other existing civil, criminal or administrative remedies are not impaired and may be in addition to the remedies in Guam Procurement laws.
- (X)9. **BIDDER'S PRICES:**
The College will consider not more than two (2) (Basic and Alternate) item prices and the bidder shall explain fully each price if supplies, materials, equipment, and/or specified

services offered comply with specifications and the product's origin. Where basic or alternate bid meets the minimum required specification, cost and other factors will be considered. Failure to explain this requirement will result in rejection of the bid.

(X)10. BID ENVELOPE:

Envelope shall be sealed and marked with the bidders' name, bid number, time, date and place of Bid Submission.

(X)11. AFFIDAVIT DISCLOSING OWNERSHIP AND COMMISSIONS (AG Form 002):

Each person submitting a bid for any portion of the work covered by the bid documents shall execute an affidavit on the form provided when the person(s) who have held more than ten percent (10%) of the company's shares during the past twelve (12) months. Such affidavit shall be attached to the bid. **Failure to submit with the bid shall be cause for rejection of bid.**

(X)12. NON-COLLUSION AFFIDAVIT (AG Form 003):

Each person submitting a bid for any portion of the work covered by the bid documents shall execute an affidavit on the form provided, certifying to the effect that he/she has not colluded with any other person, firm or corporation in regards to any bid submitted. Such affidavit shall be attached to the bid. **Failure to submit with the bid shall be cause for rejection of bid.**

(X)13. AFFIDAVIT RE GRATUITIES, KICKBACKS AND FAVORS (AG Form 004):

The bidder, offeror or contractor agrees that it will not violate the prohibition against gratuities, kickbacks, and favors set forth (Gratuities and Kickbacks) in 5 GCA, Chapter 5, Article 11. Such affidavit shall be attached to the bid. **Failure to submit with the bid shall be cause for rejection of bid.**

(X)14. AFFIDAVIT RE ETHICAL STANDARDS (AG Form 005):

The bidder, offeror, or contractor represents that it has not knowingly influenced and promises that it will not knowingly influence a government employee to breach any of the ethical standards set forth in 5 GCA Chapter 5 Article 11 (Ethics in Public Contracting) of the Guam Procurement Act and in Chapter 11 of the Guam Procurement Regulations. Such affidavit shall be attached to the bid. **Failure to submit with the bid shall be cause for rejection of bid.**

(X)15. DECLARATION RE COMPLIANCE WITH U.S. DEPARTMENT OF LABOR WAGE DETERMINATION (AG Form 006):

In compliance to wage and benefits pursuant to 5GCA §5211(b) and 5 GCA §5801 and §5802, as may be applicable, each bidder certifies that any of its employees whose purpose, in whole or part, is the direct delivery of service contracted by the Government shall be paid in accordance with the Wage Determination for Guam and the Northern Marianas Islands issued and promulgated by the U.S. Department of Labor for such Labor as is employed in the direct delivery of contract deliverables to the Government, including health and other similar benefits. **Failure to submit with the bid shall be cause for rejection of bid.**

(X)16. AFFIDAVIT REGARDING CONTINGENT FEES (AG Form 007):

The bidder, offeror, or contractor represents that it has not retained a person to solicit or secure a Government contract upon an agreement or understanding for a commission, percentage, brokerage, or contingent fee, except for retention of bona fide employees or bona fide established commercial selling agencies for the purpose of securing business. Such affidavit shall be attached to the bid. **Failure to submit with the bid shall be cause for rejection of bid.**

(X)17. BID BOND REQUIREMENT:

Bidder is required to submit a Bid Guarantee Bond or standby irrevocable Letter of Credit or Certified Check or Cashier's Check in the same bid envelope to be held by the College pending award. The Bid Guarantee Bond, Letter of Credit, Certified Check or Cashier's Check must be issued by any local surety or banking institution licensed to do business on Guam and made payable to the Guam Community College, in the amount of **fifteen percent (15%)** of the highest total bid offer. Bid guarantee will be a Bid Bond on Government Standard Form BB- (copy enclosed). Personal Checks will not be accepted as Bid Guarantee. If a successful Bidder (contractor) withdraws from the Bid or fails to enter into contract within the prescribed time, such Bond will be forfeited to the Guam Community College. **Bid will be disqualified if not accompanied by Bid Bond, Letter of Credit, Certified Check or Cashier's Check.** Bidder must include in his/her bid, valid copies of a Power of Attorney from the Surety and a Certificate of Authority from the Government to show proof that the surety company named on the bond instrument is authorized by the Government of Guam and qualified to do business on Guam. For detailed information on bonding matters, contact the Department of Revenue and Taxation. **Failure to submit a valid Power of Attorney and Certificate of Authority on the surety is cause for rejection of bid.**

(X)18. PERFORMANCE BOND REQUIREMENT:

The Bidder may be required to furnish a Performance Bond on Government Standard Form BB- or standby irrevocable Letter of Credit or Certified Check or Cashier's Check payable to the Guam Community College issued by any of the local Banks or Bonding Institution in the amount equal to **one-hundred percent (100%)** of the contract prices as security for the faithful performance and proper fulfillment of the contract. In the event that any of the provisions of this contract are violated by the contractor, the Chief Procurement Officer shall serve written notice upon both the contractor and the Surety of its intention to terminate the contract. Unless satisfactory arrangement or correction is made within the ten (10) days of such notice the contract shall cease and terminate upon the expiration of ten (10) days. In the event of any such termination, the Chief Procurement Officer shall immediately serve notice thereof upon the Surety. The Surety shall have the right to take over and perform the contract, provided, however, that if the Surety does not commence performance thereof within ten (10) days from the date of the mailing of notice of termination, the College may take over and prosecute the same to complete the contract or force account for and at the expense of the contractor, and the contractor and his Surety shall be liable to the College for any excess cost occasioned the Government.

(X)19. PERFORMANCE GUARANTEE:

Bidders who are awarded a contract under this solicitation, guarantee that goods will be delivered or required services performed within the time specified. Failure to perform the contract in a satisfactory manner may be cause for suspension or debarment from doing business with the Government and to enforce Section 12 of these General Terms and Conditions. In addition, the College will hold the Vendor liable and will enforce the requirements as set forth in Section 41 of these General Terms and Conditions.

(X)20. SURETY BONDS:

Bid and Performance Bonds coverage must be signed or countersigned in Guam by the surety's resident general agent. The Surety must be Insurance Company, authorized by the Government of Guam and qualified to do business in Guam. Bids will be disqualified if the Surety Company does not have a valid Certificate of Authority from the Government of Guam to conduct business in Guam.

(X)21. COMPETENCY OF BIDDERS:

Bids will be considered only from such bidders who, in the opinion of the Government, can show evidence of their ability, experience, equipment, and facilities to render satisfactory service.

(X)22. DETERMINATION OF RESPONSIBILITY OF BIDDERS:

The Chief Procurement Officer reserves the right to secure from bidders information to determine whether or not they are responsible and to inspect plant site, place of business; and supplies and services as necessary to determine their responsiveness.

(X)23. STANDARD FOR DETERMINATION OF LOWEST RESPONSIBLE BIDDER:

In determining the lowest responsible offer, the Chief Procurement Officer shall be guided by the following:

- a) Price of Items offered.
- b) The ability, capacity, and skill of the Bidder to perform.
- c) Whether the Bidder can perform promptly or within the specified time.
- d) The quality of performance of the Bidder with regards to award previously made to him.
- e) The previous and existing compliance by the Bidder with laws and regulations relative to procurement.
- f) The sufficiency of the financial resources and ability of the Bidder to perform.
- g) The ability of the bidder to provide future maintenance and services for the subject award.
- h) The compliance with all of the conditions to the Solicitation

(X)24. TIE BIDS:

If the bids are for the same unit price or total amount in whole or in part, the Chief Procurement Officer has the authority to award the bid to any one of the bidders by drawing lots in public, or to reject all such bids.

(X)25. BRAND NAMES:

Any reference in the Solicitation to manufacturer's Brand Names and number is due to lack of a satisfactory specification of commodity description. Such reference is intended to be descriptive, but not restrictive and for the sole purpose of indicating to prospective bidders a

description of the article or services that will be satisfactory. Bids on comparable items will be considered provided the bidder clearly states in his bid the exact articles he is offering and how it differs from the original specification.

(X)26. DESCRIPTIVE LITERATURE:

Descriptive literature(s) as specified in this solicitation must be furnished as a part of the bid and must be received at the date and time set for opening Bids. The literature furnished must clearly identify the item(s) in the Bid. The descriptive literature is required to establish, for the purpose of evaluation and award, details of the product(s) the bidder proposes to furnish including design, materials, components, performance characteristics, method of manufacture, construction, assembly or other characteristics which are considered appropriate. Rejection of the Bid will be required if the descriptive literature(s) do not show that the product(s) offered conform(s) to the specifications and other requirements of this solicitation. Failure to furnish the descriptive literature(s) by the time specified in Solicitation will require rejection of the Bid.

()27. SAMPLES:

Sample(s) of item(s) as specified in this solicitation must be furnished as a part of the bid and must be received at the date and time set for opening Bids. The sample(s) should represent exactly what the Bidder proposes to furnish and will be used to determine if the item(s) offered complies with the specifications. Rejection of the Bid will be required if the sample(s) do not show that the product(s) offered conform(s) to the specifications and other requirements of this solicitation. Failure to furnish the sample(s) by the time specified in the Solicitation will require rejection of the Bid.

()28. LABORATORY TEST:

Successful bidder is required to accompany delivery of his goods with a Laboratory Test Report indicating that the product he is furnishing the College meets the specifications. This report is on the bidder's account and must be from a certified Testing Association.

(X)29. AWARD, CANCELLATION & REJECTION:

Award shall be made to the lowest responsible and responsive bidder, whose bid is determined to be the most advantageous to the Government, taking into consideration the evaluation factors set forth in this solicitation. No other factors or criteria shall be used in the evaluation. Award issued to the lowest responsible bidder within the specified time for acceptance as indicated in the solicitation, results in a binding contract without further action by either party. The right is reserved as the interest of the Government and may require to waive any minor irregularity in the bid received pursuant to 2 GAR, Div. 4 §3109(m)(4)B).

An Invitation for Bid, Request for Proposal, or other solicitation may be cancelled, or any or all bids proposals may be rejected in whole or in part as may be specified in the solicitation, when it is in the best interest of the Territory in accordance with regulations promulgated by the Policy Office, pursuant to 5 GCA § 5225, The reasons therefore shall be made part of the contract file. Each solicitation issued by the territory shall state that the solicitation may be cancelled pursuant to 2 GAR Div. 4 §3115(c).

Each solicitation issued by the territory shall provide that any bid or proposal may be **rejected** in whole or in part when in the best interest of the Territory as provided in the regulations pursuant to 2 GAR Div. 4, §3115(e)(2).

(X)30. The College reserves the right to increase or decrease the quantity of the items for award and make additional awards for the same type items and the vendor agrees to such modifications and additional awards based on the bid prices for a period of thirty (30) days after original award. No award shall be made under this solicitation which shall require advance payment or irrevocable letter of credit from the Government. Pursuant to 2 GAR, Div. 4 §1103.

(X)31. **MARKING:**

Each outside container shall be marked with the Purchase Order number, item number, brief item description and quantity. Letter marking shall not be less than 3/4" in height.

(X)32. **SCHEDULE FOR DELIVERY:**

Successful bidder shall notify the Guam Community College, Telephone No. 735-5542/5540, at least twenty-four (24) hours before delivery of any item under this solicitation.

(X)33. **BILL OF SALE:**

Successful bidder shall render Bills of Sale for each item delivered under this contract. Failure to comply with this requirement will result in rejection of delivery. The Bills of Sale must accompany the items delivered but will not be considered as an invoice for payment. Supplier shall bill the College with an original invoice.

(X)34. **MANUFACTURER'S CERTIFICATE:**

Successful bidder is required, upon delivery of any item under this contract, to furnish a certificate from the manufacturer indicating that the goods meet the specifications. Failure to comply with this request will result in rejection of delivery.

(X)35. **INSPECTION:**

All supplies, materials, equipment, or services delivered under this contract shall be subject to the inspection and/or test conducted by the College at destination. If in any case the supplies, materials, equipment, or services are found to be defective in material, workmanship, performance, or otherwise do not conform with the specifications, the College shall have the right to reject the item(s) or require that they be corrected. The number of days required for correction will be determined by the College.

()36. **MOTOR VEHICLE SAFETY REQUIREMENTS:**

Guam Community College will only consider Bids on motor vehicles which comply with requirements of all Guam and Federal Laws.

() 37. SAFETY INSPECTION:

All motor vehicles delivered under this contract must pass the Government of Guam Vehicle Inspection before delivery at destination.

(X) 38. GUARANTEE:

a) Guarantee of Vehicle Type of Equipment: The successful bidder shall guarantee vehicular type equipment offered against defective parts, workmanship, and performance, for a period of not less than one (1) year after date of receipt of equipment. Bidder shall also provide service to the equipment for at least one (1) year. Service to be provided shall include, but will not be limited to tune-ups (change of spark plugs, contact points and condensers) and lubrication (change of engine and transmission oil). All parts and labor shall be at the expense of the bidder. All parts found defective and not caused by misuse, negligence or accident within the guarantee period shall be repaired, replaced, or adjusted within six (6) working days after notice from the College and without cost to the College. Vehicular type equipment as used in this context shall include equipment used for transportation as differentiated from tractors, backhoe, etc. b) Guarantee of Other Type Equipment: The successful bidder shall guarantee all other types of equipment offered, except those mentioned in 31a, above, against defective parts, workmanship, and performance for the life of the contract. Bidder shall also provide service to the equipment for the life of the contract. All parts found defective within that period shall be repaired or replaced by the Contractor without cost to the College. Repairs, adjustments or replacement of defective parts shall be completed by the successful bidder as set forth in the bid. c) Compliance with this Section is a condition of this Bid.

(X) 39. AMENDMENTS TO INVITATION FOR BIDS:

No changes to the IFB can be made unless a change is made by written amendment. Pursuant to 2 GAR, Div. 4, §3109(i), Amendments to Invitation For Bids shall be identified as such and shall require that the bidder acknowledge receipt of all amendments issued. The amendments shall reference the portions of the Invitation for Bids it amends.

(X) 40. RIGHT TO AUDIT RECORDS:

The territory may, at reasonable times and places, audit the books and records of any person who has submitted cost or pricing data pursuant to 5 GCA §5232 (Cost or Pricing Data) of the Guam Procurement Act, to the extent that such books and records relate to such cost or pricing data. Any person who receives a contract, change order, or contract modification for which cost or pricing data is required, shall maintain such books and records that relate to such cost or pricing data for three (3) years from the date of final payment under the contract, unless a shorter period is otherwise authorized in writing pursuant to 2 GAR §3124(a).

(X) 41. EQUAL EMPLOYMENT OPPORTUNITY:

Contractors shall not discriminate against any employee or applicant for employment because of race, color, religion, sex, or national origin. The contractor will take affirmative action to ensure that employees are treated equally during employment without regards to their race, color, religion, sex, or national origin.

(X)42. COMPLIANCE WITH LAWS:

Bidders awarded a contract under this Solicitation shall comply with the applicable standards, provisions, and stipulations of all pertinent Federal and/or local laws, rules, and regulations relative to the performance of this contract and the furnishing of goods.

(X)43. CHANGE ORDER:

Any change order issued relative to awards made under this solicitation will be subject to and in accordance with the provisions of the Guam Procurement Laws.

(X)44. STOP WORK ORDER:

Any stop work issued relative to awards made under this solicitation will be subject to and in accordance with 2 GAR Div 4, §6101 (4)(c) of the Guam Procurement Laws.

(X)45. TERMINATION FOR CONVENIENCE:

Any termination order for the convenience of the College issued relative to awards made under this solicitation will be subject to and in accordance with the Guam Procurement Laws.

(X)46. TIME FOR COMPLETION:

It is hereby understood and mutually agreed by and between the contractor and the College that the time for delivery to final destination or the timely performance of certain services is an essential condition of this contract. If the contractor refuses or fails to perform any of the provisions of this contract within the time specified in the Purchase Order (from the date Purchase Order is acknowledged by vendor), then the contractor is in default. Defaults will be treated subject to and in accordance with the provisions of the Guam Procurement Laws.

(X)47. JUSTIFICATION OF DELAY:

Bidders who are awarded contracts under this Solicitation, guarantee that the goods will be delivered to their destination or required services rendered within the time specified. If the bidder is not able to meet the specified delivery date, he is required to notify the Chief Procurement Officer of such delay. Notification shall be in writing and shall be received by the Chief Procurement Officer at least twenty-four (24) hours before this specified delivery date. Notification of delay shall include an explanation of the causes and reasons for the delay including statement(s) from supplier or shipping company causing the delay. The College reserves the right to reject delay justification if, in the opinion of the Chief Procurement Officer, such justification is not adequate.

(X) 48. LIQUIDATED DAMAGES:

When the Contractor is given notice of delay or non-performance as specified in Paragraph 1 (Default) of the Termination for Default Clause on this contract and fails to cure in the time specified, the contractor shall be liable for damages for delay in the amount of one-fourth of one percent (1%) of outstanding order per calendar day from date set for cure until either the territory reasonably obtains similar supplies or services if the contractor is terminated for default, or until the contractor provided the supplies or services if the contractor's delay or non-

performance is excused under Paragraph 40 (Excuse for Non-Performance or Delayed Performance) of the Termination for Default of this contract, liquidated damages shall not be due the territory. The contractor remains liable for damages caused other than by delay.

(X)49. PHYSICAL LIABILITY:

If it becomes necessary for the Vendor, either as principal, agent or employee, to enter upon the premises or property of the Guam Community College in order to construct, erect, inspect, make delivery or remove property hereunder, the Vendor hereby covenants and agrees to take, use, provide and make all proper, necessary and sufficient precautions, safeguards and protection against the occurrence of any accidents, injuries or damages to any person or property during the progress of the work herein covered, and to be responsible for, and incurred for or by reason of the violations of any territorial ordinance, regulations, or the laws of Guam or the United States, while the work is in progress. Contractor will carry insurance to indemnify the Guam Community College against any claim for loss, damage or injury to property or persons arising out of the performance of the Contractor or his employees and agents of the services covered by the Contract and the use/misuse or failure of any equipment used by the contractor or his employees or agents, and shall provide certificates of such insurance to the Guam Community College when required.

() 50. HIRING OF APPRENTICES THROUGH THE APPRENTICE TRAINING PROGRAM:

It is the policy of the Government of Guam that all construction projects funded in whole or in part by local or federal funds shall require the contractor to employ at least: One (1) apprentice for every Ten (10) workers for the duration of each project, and not less than one (1) apprentice per project. This requirement may only be waived if the contractor certifies that no apprentice is available. It applies only to projects over Five Hundred Thousand Dollars (\$500,000).

() 51. BUY AMERICAN PRODUCT:

Buy American requirement – all iron, steel, & manufactured goods used in project are produced in the United States.

(X)52. SERVICE-DISABLED VETERAN OWNED BUSINESS PREFERENCE:

Bidding is subject to the policy in favor of Service-Disabled Veteran Owned Business as defined in 5 GCA §5011 and §5012.

(X)53. RESTRICTIONS ON SEX OFFENDERS:

Upon Notice of Intent to Award, the selected Bidder will be required to submit a list of the names of individuals assigned to this project. This is to ensure that the workers assigned to this project are not on the Sex Offender Registry as required by P.L. 28-98.

The Contractor must warrant that no person shall provide services on his behalf in relation to this contract who has been convicted of sex offense under the provisions of **Chapter 25 of Title 9 GCA** or an offense as defined in **Article 2 of Chapter 28, Title 9 GCA** or an offense in another jurisdiction with, at a minimum, the same elements as such offenses, or who is listed in the Sex Offender Registry. Any such person who is discovered to have been so convicted shall be immediately removed from working at Guam Community College and the President shall be informed within twenty-four (24) hours. Failure to take corrective action after notice may result in the temporary suspension of the Agreement at the discretion of the Government.

54. **DAVIS-BACON AND RELATED ACTS:**

This is a Federally Funded Project – Contractor is required to comply with the Davis Bacon and Related Acts (DBRA), which requires all contractors and subcontractors performing work on federal construction projects or federally assisted contracts in excess of \$2,000 to pay their laborers and mechanics not less than the prevailing wage rate and fringe benefits for corresponding classes of laborers and mechanics employed on similar projects in the area. The prevailing wage rates and fringe benefits are determined by the Secretary of Labor for inclusion in covered contracts.

RECORDKEEPING -- Under the Davis-Bacon and Related Acts, covered contractors must maintain payrolls and basic records and submit certified weekly payrolls. Although use of Form WH-347 is optional, the form will satisfy the requirements of Regulations, Parts 3 and 5 (29CFR, Subtitle A), as to payrolls submitted in connection with contracts subject to the DBRA. Records to be maintained include: Name, address, and social security number of each employee; each employee's work classification(s); hourly rate(s) of pay (including rates of contributions or cost anticipated for bona fide fringe benefits or cash equivalents thereof; Daily and weekly number of hours worked; Deductions made and Actual wages paid.

55. **COMPLIANCE WITH THE NATIONAL DEFENSE AUTHORIZATION ACT (NDAA) AND SPECIFICALLY SECTION 889:**

Section 889 aims to protect National Security by limiting the government's access to "covered" equipment or services manufactured or provided by certain companies or their subsidiaries or affiliates with know ties to the People's Republic of China.

56. **CONTACT FOR CONTRACT ADMINISTRATION:**

If your firm receives a contract as a result of this Solicitation, please designate a person whom we may contact for prompt administration.

Name: _____ Title: _____
Address: _____ Telephone: _____

GOVERNMENT OF GUAM

GUAM COMMUNITY COLLEGE
P.O. BOX 23069 GMF
BARRIGADA, GUAM 96921

BID BOND NO. _____

KNOW ALL MEN BY THESE PRESENTS that _____, as Principal hereinafter called the Principal, and (Bonding Company), _____ a duly admitted insurer under the laws of the Territory of Guam, as Surety, hereinafter called the Surety are held firmly bound unto) the Territory of Guam for the sum of _____ Dollars (\$ _____), for payment of which sum will and truly to be made, the said(Principal and the said Surety bind ourselves, our heirs, executors, administrators, successors and assigns, jointly and severally, firmly by these presents.

WHEREAS, the Principal has submitted a bid for *(identify project by number and brief description)* _____

NOW THEREFORE, If the Territory of Guam shall accept the bid of the Principal and the Principal shall enter into a Contract with the Territory of Guam in accordance with the terms of such bid, and give such bond or bonds as may be specified in bidding or Contract Documents with good and sufficient surety for the faithful performance of such Contract and for the prompt payment of labor and material furnished in the prosecution, thereof, or in the event of the failure of the Principal to enter such Contract and give such bond or bonds, if the Principal shall pay to the Territory of Guam the difference not to exceed the penalty hereof between the amounts specified in said bid and such larger amount for which the Territory of Guam may in good faith contract with another party to perform work covered by said bid or an appropriate liquidated amount as specified in the Invitation for Bids then this obligation shall be null and void, otherwise to remain in full force and effect.

Signed and sealed this _____ day of _____ 20____.

(PRINCIPAL) (SEAL)

(WITNESS)

(TITLE)

(MAJOR OFFICER OF SURETY)

(TITLE)

(MAJOR OFFICER OF SURETY)

(TITLE)

(RESIDENT GENERAL AGENT)

SEE INSTRUCTIONS IN BACK PAGE FOR SUPPORTING DOCUMENTS REQUIRED.
DOA 113/Rev 4-1-87

GCC PR0029

INSTRUCTIONS TO PROVIDERS:

NOTICE to all Insurance and Bonding Institutions:

The Bond requires the signatures of the Vendor, two (2) major Officers of the Surety and Resident General Agent, if the Surety is a foreign or alien surety.

When the form is submitted to General Services Agency, it should be accompanied with the copies of the following:

1. Current Certificate of Authority to do business on Guam Issued by the Department of Revenue and Taxation.
2. Power of Attorney issued by the Surety to the Resident General Agent.
3. Power of Attorney issued by two (2) major officers of the Surety to whoever is signing on their behalf.

Bonds submitted as Bid Guarantee, without signatures and supporting documents are invalid and bids will be rejected.

PERFORMANCE BOND

BOND NO. _____

KNOW ALL MEN BY THESE PRESENTS that _____ *(Insert full name and address or legal title of Contractor)* as Principal, hereinafter called Contractor, and (Surety), a duly admitted insurer under the laws of the Territory of Guam as Surety, hereinafter called Surety, are held and firmly bound unto Guam Community College as Obligee, in the amount of _____ Dollars (\$_____) for the payment whereof Contractor and Surety bind themselves, their heirs, executors, administrators, successors and assigns, jointly and severally, firmly by these presents.

WHEREAS, Contractor has by written agreement dated, _____, 20____, entered into a contract with Guam Community College for _____ in accordance with drawings and specifications prepared by *(insert full name and address or legal title of architect)* _____ which contract is by reference made a part of hereof, and is hereinafter referred to as the Contract.

NOW, THEREFORE, THE CONDITION OF THIS OBLIGATION is such that, if Contractor shall promptly and faithfully perform said Contract then this obligation shall be null and void; otherwise it shall remain in full force and effect. The Surety hereby waives notice of any alteration or extension provided the same is within the scope of the Contract. Whenever Contractor shall be and is declared by Guam Community College to be in default under the Contract, Guam Community College having performed GCC obligations thereunder, the Surety may promptly remedy the default or shall promptly:

1. Complete the Contract in accordance with its terms and obligations; or
2. Obtain a bid or bids for completing the Contract in accordance with its terms and conditions, and upon determination by Guam Community College and the Surety jointly of the lowest responsive, responsible bidder, arrange for a contract (between such bidder and Guam Community College and make available as work progresses (even though there should be a default or a succession of defaults under the contract or contracts of completion arranged under this paragraph) sufficient funds to pay the cost of completion less the balance of the contract price; but not exceeding, including other costs and damages for which the Surety may be liable hereunder, the amount set forth in the first paragraph hereof. The term "balance of the contract price," as used in this paragraph shall mean the total amount payable by Guam Community College to the Contractor under the Contract and any amendments thereto, less the amount properly paid by the Guam Community College to the Contractor. No right of action shall accrue on this bond to or for the use of any person or corporation other than Guam Community College or successors of Guam Community College.

Signed and sealed this _____ day of _____, 20____.

(Principal) (Seal)

(Witness) _____

(Title) _____

(Surety) _____

(Title) _____

(Bonding Company)

(Title)

BY:

(Resident General Agent)

AFFIDAVIT DISCLOSING OWNERSHIP AND COMMISSIONS

CITY OF _____)
) ss.
 ISLAND OF GUAM)

A. I, the undersigned, being first duly sworn, depose and say that I am an authorized representative of the offeror and that *[please check only one]*:

- The offeror is an individual or sole proprietor and owns the entire (100%) interest in the offering business.
- The offeror is a corporation, partnership, joint venture, or association known as _____ *[please state name of offeror company]*, and the persons, companies, partners, or joint venturers who have held more than 10% of the shares or interest in the offering business during the 365 days immediately preceding the submission date of the proposal are as follows *[if none, please so state]*:

<u>Name</u>	<u>Address</u>	<u>% of Interest</u>
_____	_____	_____
_____	_____	_____
_____	_____	_____

B. Further, I say that the persons who have received or are entitled to receive a commission, gratuity or other compensation for procuring or assisting in obtaining business related to the bid or proposal for which this affidavit is submitted are as follows *[if none, please so state]*:

<u>Name</u>	<u>Address</u>	<u>Compensation</u>
_____	_____	_____

C. If the ownership of the offering business should change between the time this affidavit is made and the time an award is made or a contract is entered into, then I promise personally to update the disclosure required by 5 GCA §5233 by delivering another affidavit to the government.

 Signature of one of the following:

- Offeror, if the offeror is an individual;
- Partner, if the offeror is a partnership;
- Officer, if the offeror is a corporation.

Subscribed and sworn to before me
 this ____ day of _____, 20__.

 NOTARY PUBLIC
 My commission expires: _____

AFFIDAVIT RE NON-COLLUSION

CITY OF _____)
) SS.
ISLAND OF GUAM)

_____ [state name of affiant signing below], being first duly sworn, deposes and says that:

1. The name of the offering company or individual is [state name of company] _____.

2. The proposal for the solicitation identified above is genuine and not collusive or a sham. The offeror has not colluded, conspired, connived or agreed, directly or indirectly, with any other offeror or person, to put in a sham proposal or to refrain from making an offer. The offeror has not in any manner, directly or indirectly, sought by an agreement or collusion, or communication or conference, with any person to fix the proposal price of offeror or of any other offeror, or to fix any overhead, profit or cost element of said proposal price, or of that of any other offeror, or to secure any advantage against the government of Guam or any other offeror, or to secure any advantage against the government of Guam or any person interested in the proposed contract. All statements in this affidavit and in the proposal are true to the best of the knowledge of the undersigned. This statement is made pursuant to 2 GAR Division 4 § 3126(b).

3. I make this statement on behalf of myself as a representative of the offeror, and on behalf of the offeror's officers, representatives, agents, subcontractors, and employees.

Signature of one of the following:
Offeror, if the offeror is an individual;
Partner, if the offeror is a partnership;
Officer, if the offeror is a corporation.

Subscribed and sworn to before me
this ____ day of _____, 20__.

NOTARY PUBLIC
My commission expires _____, _____.

AFFIDAVIT RE GRATUITIES OR KICKBACKS

CITY OF _____)
) ss.
 ISLAND OF GUAM)

_____ [state name of affiant signing below], being first duly sworn, deposes and says that:

1. The name of the offering firm or individual is [state name of offeror company] _____ . Affiant is _____ [state one of the following: the offeror, a partner of the offeror, an officer of the offeror] making the foregoing identified bid or proposal.

2. To the best of affiant's knowledge, neither affiant, nor any of the offeror's officers, representatives, agents, subcontractors, or employees have violated, are violating the prohibition against gratuities and kickbacks set forth in 2 GAR Division 4 § 11107(e). Further, affiant promises, on behalf of offeror, not to violate the prohibition against gratuities and kickbacks as set forth in 2 GAR Division 4 § 11107(e).

3. To the best of affiant's knowledge, neither affiant, nor any of the offeror's officers, representatives, agents, subcontractors, or employees have offered, given or agreed to give, any government of Guam employee or former government employee, any payment, gift, kickback, gratuity or offer of employment in connection with the offeror's proposal.

4. I make these statements on behalf of myself as a representative of the offeror, and on behalf of the offeror's officers, representatives, agents, subcontractors, and employees.

 Signature of one of the following:

Offeror, if the offeror is an individual;
 Partner, if the offeror is a partnership;
 Officer, if the offeror is a corporation.

Subscribed and sworn to before me

this _____ day of _____, 20_____.

 NOTARY PUBLIC
 My commission expires _____, _____.

AFFIDAVIT RE ETHICAL STANDARDS

CITY OF _____)
ISLAND OF GUAM) ss.

_____ [state name of affiant signing below], being first duly sworn, deposes and says that:

The affiant is _____ [state one of the following: the offeror, a partner of the offeror, an officer of the offeror] making the foregoing identified bid or proposal. To the best of affiant's knowledge, neither affiant nor any officers, representatives, agents, subcontractors or employees of offeror have knowingly influenced any government of Guam employee to breach any of the ethical standards set forth in 5 GCA Chapter 5, Article 11. Further, affiant promises that neither he or she, nor any officer, representative, agent, subcontractor, or employee of offeror will knowingly influence any government of Guam employee to breach any ethical standards set forth in 5 GCA Chapter 5, Article 11. These statements are made pursuant to 2 GAR Division 4 § 11103(b).

Signature of one of the following:

- Offeror, if the offeror is an individual;
- Partner, if the offeror is a partnership;
- Officer, if the offeror is a corporation.

Subscribed and sworn to before me
this ____ day of _____, 20 _____.

NOTARY PUBLIC
My commission expires _____, _____.

DECLARATION RE COMPLIANCE WITH U.S. DOL WAGE DETERMINATION

Procurement No.: _____

Name of Offeror Company: _____

I, _____ hereby certify under penalty of perjury:

(1) That I am _____ [please select one: the offeror, a partner of the offeror, an officer of the offeror] making the bid or proposal in the foregoing identified procurement;

(2) That I have read and understand the provisions of 5 GCA § 5801 and § 5802 which read:

§ 5801. Wage Determination Established.

In such cases where the government of Guam enters into contractual arrangements with a sole proprietorship, a partnership or a corporation ("contractor") for the provision of a service to the government of Guam, and in such cases where the contractor employs a person(s) whose purpose, in whole or in part, is the direct delivery of service contracted by the government of Guam, then the contractor shall pay such employee(s) in accordance with the Wage Determination for Guam and the Northern Mariana Islands issued and promulgated by the U.S. Department of Labor for such labor as is employed in the direct delivery of contract deliverables to the government of Guam.

The Wage Determination most recently issued by the U.S. Department of Labor at the time a contract is awarded to a contractor by the government of Guam shall be used to determine wages, which shall be paid to employees pursuant to this Article. Should any contract contain a renewal clause, then at the time of renewal adjustments, there shall be made stipulations contained in that contract for applying the Wage Determination, as required by this Article, so that the Wage Determination promulgated by the U.S. Department of Labor on a date most recent to the renewal date shall apply.

§ 5802. Benefits.

In addition to the Wage Determination detailed in this Article, any contract to which this Article applies shall also contain provisions mandating health and similar benefits for employees covered by this Article, such benefits having a minimum value as detailed in the Wage Determination issued and promulgated by the U.S. Department of Labor, and shall contain provisions guaranteeing a minimum of ten (10) paid holidays per annum per employee.

(3) That the offeror is in full compliance with 5 GCA § 5801 and § 5802, as may be applicable to the procurement referenced herein;

(4) That I have attached the most recent wage determination applicable to Guam issued by the U.S. Department of Labor. [INSTRUCTIONS - Please attach!]

Signature

"REGISTER OF WAGE DETERMINATIONS UNDER
THE SERVICE CONTRACT ACT
By direction of the Secretary of Labor

U.S. DEPARTMENT OF LABOR
EMPLOYMENT STANDARDS ADMINISTRATION
WAGE AND HOUR DIVISION
WASHINGTON D.C. 20210

Daniel W. Simms
Director

Division of
Wage Determinations

Wage Determination No.: 2015-5693
Revision No.: 12
Date Of Last Revision: 12/21/2020

Note: Under Executive Order (EO) 13658 an hourly minimum wage of \$10.95 for calendar year 2021 applies to all contracts subject to the Service Contract Act for which the contract is awarded (and any solicitation was issued) on or after January 1 2015. If this contract is covered by the EO the contractor must pay all workers in any classification listed on this wage determination at least \$10.95 per hour (or the applicable wage rate listed on this wage determination if it is higher) for all hours spent performing on the contract in calendar year 2021. The EO minimum wage rate will be adjusted annually. Additional information on contractor requirements and worker protections under the EO is available at www.dol.gov/whd/govcontracts.

States: Guam Northern Marianas Wake Island

Area: Guam Statewide

Northern Marianas Statewide

Wake Island Statewide

****Fringe Benefits Required Follow the Occupational Listing****

OCCUPATION CODE - TITLE	FOOTNOTE	RATE
01000 - Administrative Support And Clerical Occupations		
01011 - Accounting Clerk I		13.57
01012 - Accounting Clerk II		15.23
01013 - Accounting Clerk III		17.04
01020 - Administrative Assistant		21.43
01035 - Court Reporter		17.40
01041 - Customer Service Representative I		11.51
01042 - Customer Service Representative II		12.94
01043 - Customer Service Representative III		14.12
01051 - Data Entry Operator I		12.15
01052 - Data Entry Operator II		13.25
01060 - Dispatcher Motor Vehicle		15.81

GCC PR0037

01070 - Document Preparation Clerk	13.85
01090 - Duplicating Machine Operator	13.85
01111 - General Clerk I	10.35
01112 - General Clerk II	11.29
01113 - General Clerk III	12.68
01120 - Housing Referral Assistant	19.39
01141 - Messenger Courier	11.37
01191 - Order Clerk I	12.57
01192 - Order Clerk II	13.71
01261 - Personnel Assistant (Employment) I	15.95
01262 - Personnel Assistant (Employment) II	17.85
01263 - Personnel Assistant (Employment) III	19.89
01270 - Production Control Clerk	21.78
01290 - Rental Clerk	11.10
01300 - Scheduler Maintenance	15.55
01311 - Secretary I	15.55
01312 - Secretary II	17.40
01313 - Secretary III	19.39
01320 - Service Order Dispatcher	14.00
01410 - Supply Technician	21.43
01420 - Survey Worker	16.79
01460 - Switchboard Operator/Receptionist	9.67
01531 - Travel Clerk I	13.01
01532 - Travel Clerk II	14.12
01533 - Travel Clerk III	15.09
01611 - Word Processor I	14.53
01612 - Word Processor II	16.31
01613 - Word Processor III	18.26
05000 - Automotive Service Occupations	
05005 - Automobile Body Repairer Fiberglass	14.82
05010 - Automotive Electrician	13.92
05040 - Automotive Glass Installer	13.02
05070 - Automotive Worker	13.02
05110 - Mobile Equipment Servicer	11.16
05130 - Motor Equipment Metal Mechanic	14.82
05160 - Motor Equipment Metal Worker	13.02
05190 - Motor Vehicle Mechanic	14.82
05220 - Motor Vehicle Mechanic Helper	10.22
05250 - Motor Vehicle Upholstery Worker	12.11
05280 - Motor Vehicle Wrecker	13.02
05310 - Painter Automotive	13.92
05340 - Radiator Repair Specialist	13.02
05370 - Tire Repairer	12.34
05400 - Transmission Repair Specialist	14.82
07000 - Food Preparation And Service Occupations	
07010 - Baker	10.47
07041 - Cook I	12.05
07042 - Cook II	14.05
07070 - Dishwasher	9.28
07130 - Food Service Worker	9.34

07210 - Meat Cutter	11.86
07260 - Waiter/Waitress	9.23
09000 - Furniture Maintenance And Repair Occupations	
09010 - Electrostatic Spray Painter	18.04
09040 - Furniture Handler	10.95
09080 - Furniture Refinisher	18.04
09090 - Furniture Refinisher Helper	13.27
09110 - Furniture Repairer Minor	15.70
09130 - Upholsterer	18.04
11000 - General Services And Support Occupations	
11030 - Cleaner Vehicles	9.35
11060 - Elevator Operator	9.35
11090 - Gardener	13.00
11122 - Housekeeping Aide	9.44
11150 - Janitor	9.44
11210 - Laborer Grounds Maintenance	9.82
11240 - Maid or Houseman	9.26
11260 - Pruner	8.79
11270 - Tractor Operator	11.90
11330 - Trail Maintenance Worker	9.82
11360 - Window Cleaner	10.54
12000 - Health Occupations	
12010 - Ambulance Driver	17.77
12011 - Breath Alcohol Technician	17.77
12012 - Certified Occupational Therapist Assistant	24.38
12015 - Certified Physical Therapist Assistant	24.38
12020 - Dental Assistant	15.02
12025 - Dental Hygienist	32.84
12030 - EKG Technician	25.99
12035 - Electroneurodiagnostic Technologist	25.99
12040 - Emergency Medical Technician	17.77
12071 - Licensed Practical Nurse I	15.88
12072 - Licensed Practical Nurse II	17.77
12073 - Licensed Practical Nurse III	19.81
12100 - Medical Assistant	12.26
12130 - Medical Laboratory Technician	18.82
12160 - Medical Record Clerk	13.61
12190 - Medical Record Technician	17.77
12195 - Medical Transcriptionist	15.88
12210 - Nuclear Medicine Technologist	39.04
12221 - Nursing Assistant I	11.34
12222 - Nursing Assistant II	12.75
12223 - Nursing Assistant III	13.91
12224 - Nursing Assistant IV	15.61
12235 - Optical Dispenser	17.77
12236 - Optical Technician	15.88
12250 - Pharmacy Technician	15.49
12280 - Phlebotomist	15.33
12305 - Radiologic Technologist	23.03
12311 - Registered Nurse I	22.53

12312 - Registered Nurse II	27.56
12313 - Registered Nurse II Specialist	27.56
12314 - Registered Nurse III	33.34
12315 - Registered Nurse III Anesthetist	33.34
12316 - Registered Nurse IV	39.96
12317 - Scheduler (Drug and Alcohol Testing)	22.01
12320 - Substance Abuse Treatment Counselor	22.01
13000 - Information And Arts Occupations	
13011 - Exhibits Specialist I	20.35
13012 - Exhibits Specialist II	25.20
13013 - Exhibits Specialist III	30.83
13041 - Illustrator I	20.35
13042 - Illustrator II	25.20
13043 - Illustrator III	30.83
13047 - Librarian	27.91
13050 - Library Aide/Clerk	16.20
13054 - Library Information Technology Systems Administrator	25.20
13058 - Library Technician	16.64
13061 - Media Specialist I	18.18
13062 - Media Specialist II	20.35
13063 - Media Specialist III	22.68
13071 - Photographer I	18.18
13072 - Photographer II	20.35
13073 - Photographer III	25.20
13074 - Photographer IV	30.83
13075 - Photographer V	37.30
13090 - Technical Order Library Clerk	20.35
13110 - Video Teleconference Technician	17.38
14000 - Information Technology Occupations	
14041 - Computer Operator I	15.71
14042 - Computer Operator II	17.22
14043 - Computer Operator III	19.19
14044 - Computer Operator IV	21.33
14045 - Computer Operator V	23.62
14071 - Computer Programmer I	(see 1) 15.73
14072 - Computer Programmer II	(see 1) 19.50
14073 - Computer Programmer III	(see 1) 23.84
14074 - Computer Programmer IV	(see 1)
14101 - Computer Systems Analyst I	(see 1) 24.23
14102 - Computer Systems Analyst II	(see 1)
14103 - Computer Systems Analyst III	(see 1)
14150 - Peripheral Equipment Operator	15.71
14160 - Personal Computer Support Technician	21.33
14170 - System Support Specialist	21.24
15000 - Instructional Occupations	
15010 - Aircrew Training Devices Instructor (Non-Rated)	24.23
15020 - Aircrew Training Devices Instructor (Rated)	29.32
15030 - Air Crew Training Devices Instructor (Pilot)	34.91
15050 - Computer Based Training Specialist / Instructor	24.23

15060 - Educational Technologist	27.61
15070 - Flight Instructor (Pilot)	34.91
15080 - Graphic Artist	20.47
15085 - Maintenance Test Pilot Fixed Jet/Prop	34.91
15086 - Maintenance Test Pilot Rotary Wing	34.91
15088 - Non-Maintenance Test/Co-Pilot	34.91
15090 - Technical Instructor	17.67
15095 - Technical Instructor/Course Developer	21.62
15110 - Test Proctor	14.27
15120 - Tutor	14.27
16000 - Laundry Dry-Cleaning Pressing And Related Occupations	
16010 - Assembler	9.88
16030 - Counter Attendant	9.88
16040 - Dry Cleaner	11.30
16070 - Finisher Flatwork Machine	9.88
16090 - Presser Hand	9.88
16110 - Presser Machine Drycleaning	9.88
16130 - Presser Machine Shirts	9.88
16160 - Presser Machine Wearing Apparel Laundry	9.88
16190 - Sewing Machine Operator	11.94
16220 - Tailor	12.44
16250 - Washer Machine	10.36
19000 - Machine Tool Operation And Repair Occupations	
19010 - Machine-Tool Operator (Tool Room)	18.04
19040 - Tool And Die Maker	22.67
21000 - Materials Handling And Packing Occupations	
21020 - Forklift Operator	13.96
21030 - Material Coordinator	21.78
21040 - Material Expediter	21.78
21050 - Material Handling Laborer	11.37
21071 - Order Filler	9.66
21080 - Production Line Worker (Food Processing)	13.96
21110 - Shipping Packer	15.92
21130 - Shipping/Receiving Clerk	15.92
21140 - Store Worker I	14.76
21150 - Stock Clerk	20.75
21210 - Tools And Parts Attendant	13.96
21410 - Warehouse Specialist	13.96
23000 - Mechanics And Maintenance And Repair Occupations	
23010 - Aerospace Structural Welder	22.76
23019 - Aircraft Logs and Records Technician	17.70
23021 - Aircraft Mechanic I	21.67
23022 - Aircraft Mechanic II	22.76
23023 - Aircraft Mechanic III	23.91
23040 - Aircraft Mechanic Helper	15.07
23050 - Aircraft Painter	20.35
23060 - Aircraft Servicer	17.70
23070 - Aircraft Survival Flight Equipment Technician	20.35
23080 - Aircraft Worker	19.12
23091 - Aircrew Life Support Equipment (ALSE) Mechanic	19.12

I		
23092	- Aircrew Life Support Equipment (ALSE) Mechanic	21.67
II		
23110	- Appliance Mechanic	18.04
23120	- Bicycle Repairer	14.49
23125	- Cable Splicer	19.59
23130	- Carpenter Maintenance	16.07
23140	- Carpet Layer	16.86
23160	- Electrician Maintenance	18.05
23181	- Electronics Technician Maintenance I	16.86
23182	- Electronics Technician Maintenance II	18.04
23183	- Electronics Technician Maintenance III	19.55
23260	- Fabric Worker	15.70
23290	- Fire Alarm System Mechanic	15.43
23310	- Fire Extinguisher Repairer	14.49
23311	- Fuel Distribution System Mechanic	19.21
23312	- Fuel Distribution System Operator	14.49
23370	- General Maintenance Worker	11.96
23380	- Ground Support Equipment Mechanic	21.67
23381	- Ground Support Equipment Servicer	17.70
23382	- Ground Support Equipment Worker	19.12
23391	- Gunsmith I	14.49
23392	- Gunsmith II	16.86
23393	- Gunsmith III	19.21
23410	- Heating Ventilation And Air-Conditioning Mechanic	17.16
23411	- Heating Ventilation And Air Contidioning Mechanic (Research Facility)	18.25
23430	- Heavy Equipment Mechanic	18.35
23440	- Heavy Equipment Operator	17.12
23460	- Instrument Mechanic	19.21
23465	- Laboratory/Shelter Mechanic	18.04
23470	- Laborer	11.37
23510	- Locksmith	18.04
23530	- Machinery Maintenance Mechanic	23.13
23550	- Machinist Maintenance	19.21
23580	- Maintenance Trades Helper	10.67
23591	- Metrology Technician I	19.21
23592	- Metrology Technician II	20.42
23593	- Metrology Technician III	21.63
23640	- Millwright	19.21
23710	- Office Appliance Repairer	18.04
23760	- Painter Maintenance	13.95
23790	- Pipefitter Maintenance	18.39
23810	- Plumber Maintenance	17.27
23820	- Pneudraulic Systems Mechanic	19.21
23850	- Rigger	19.21
23870	- Scale Mechanic	16.86
23890	- Sheet-Metal Worker Maintenance	16.09
23910	- Small Engine Mechanic	16.86

23931 - Telecommunications Mechanic I	19.01
23932 - Telecommunications Mechanic II	19.91
23950 - Telephone Lineman	18.24
23960 - Welder Combination Maintenance	17.95
23965 - Well Driller	19.21
23970 - Woodcraft Worker	19.21
23980 - Woodworker	14.49
24000 - Personal Needs Occupations	
24550 - Case Manager	14.72
24570 - Child Care Attendant	10.09
24580 - Child Care Center Clerk	13.25
24610 - Chore Aide	11.62
24620 - Family Readiness And Support Services Coordinator	14.72
24630 - Homemaker	16.12
25000 - Plant And System Operations Occupations	
25010 - Boiler Tender	19.21
25040 - Sewage Plant Operator	21.59
25070 - Stationary Engineer	19.21
25190 - Ventilation Equipment Tender	13.27
25210 - Water Treatment Plant Operator	21.59
27000 - Protective Service Occupations	
27004 - Alarm Monitor	10.90
27007 - Baggage Inspector	9.40
27008 - Corrections Officer	12.05
27010 - Court Security Officer	12.05
27030 - Detection Dog Handler	10.90
27040 - Detention Officer	12.05
27070 - Firefighter	12.05
27101 - Guard I	9.40
27102 - Guard II	10.90
27131 - Police Officer I	12.05
27132 - Police Officer II	13.40
28000 - Recreation Occupations	
28041 - Carnival Equipment Operator	12.79
28042 - Carnival Equipment Repairer	13.97
28043 - Carnival Worker	9.45
28210 - Gate Attendant/Gate Tender	13.18
28310 - Lifeguard	11.01
28350 - Park Attendant (Aide)	14.74
28510 - Recreation Aide/Health Facility Attendant	11.84
28515 - Recreation Specialist	18.26
28630 - Sports Official	11.74
28690 - Swimming Pool Operator	17.71
29000 - Stevedoring/Longshoremen Occupational Services	
29010 - Blocker And Bracer	23.62
29020 - Hatch Tender	23.62
29030 - Line Handler	23.62
29041 - Stevedore I	21.98
29042 - Stevedore II	25.26

30000 - Technical Occupations	
30010 - Air Traffic Control Specialist Center (HFO) (see 2)	39.89
30011 - Air Traffic Control Specialist Station (HFO) (see 2)	27.50
30012 - Air Traffic Control Specialist Terminal (HFO) (see 2)	30.29
30021 - Archeological Technician I	17.49
30022 - Archeological Technician II	19.56
30023 - Archeological Technician III	24.21
30030 - Cartographic Technician	23.18
30040 - Civil Engineering Technician	23.08
30051 - Cryogenic Technician I	25.57
30052 - Cryogenic Technician II	28.24
30061 - Drafter/CAD Operator I	17.49
30062 - Drafter/CAD Operator II	19.56
30063 - Drafter/CAD Operator III	20.77
30064 - Drafter/CAD Operator IV	25.57
30081 - Engineering Technician I	14.84
30082 - Engineering Technician II	16.66
30083 - Engineering Technician III	18.64
30084 - Engineering Technician IV	23.08
30085 - Engineering Technician V	28.24
30086 - Engineering Technician VI	34.16
30090 - Environmental Technician	23.08
30095 - Evidence Control Specialist	23.08
30210 - Laboratory Technician	20.77
30221 - Latent Fingerprint Technician I	25.57
30222 - Latent Fingerprint Technician II	28.24
30240 - Mathematical Technician	23.34
30361 - Paralegal/Legal Assistant I	19.44
30362 - Paralegal/Legal Assistant II	23.94
30363 - Paralegal/Legal Assistant III	29.29
30364 - Paralegal/Legal Assistant IV	35.44
30375 - Petroleum Supply Specialist	28.24
30390 - Photo-Optics Technician	21.93
30395 - Radiation Control Technician	28.24
30461 - Technical Writer I	23.08
30462 - Technical Writer II	28.24
30463 - Technical Writer III	34.16
30491 - Unexploded Ordnance (UXO) Technician I	25.35
30492 - Unexploded Ordnance (UXO) Technician II	30.67
30493 - Unexploded Ordnance (UXO) Technician III	36.76
30494 - Unexploded (UXO) Safety Escort	25.35
30495 - Unexploded (UXO) Sweep Personnel	25.35
30501 - Weather Forecaster I	25.57
30502 - Weather Forecaster II	31.09
30620 - Weather Observer Combined Upper Air Or Surface Programs	(see 2) 20.77
30621 - Weather Observer Senior	(see 2) 23.08
31000 - Transportation/Mobile Equipment Operation Occupations	
31010 - Airplane Pilot	30.67
31020 - Bus Aide	8.15

31030 - Bus Driver	9.69
31043 - Driver Courier	9.69
31260 - Parking and Lot Attendant	9.91
31290 - Shuttle Bus Driver	10.59
31310 - Taxi Driver	10.37
31361 - Truckdriver Light	10.59
31362 - Truckdriver Medium	11.61
31363 - Truckdriver Heavy	13.92
31364 - Truckdriver Tractor-Trailer	13.92
99000 - Miscellaneous Occupations	
99020 - Cabin Safety Specialist	14.95
99030 - Cashier	9.48
99050 - Desk Clerk	9.70
99095 - Embalmer	25.35
99130 - Flight Follower	25.35
99251 - Laboratory Animal Caretaker I	22.67
99252 - Laboratory Animal Caretaker II	24.77
99260 - Marketing Analyst	21.54
99310 - Mortician	25.35
99410 - Pest Controller	14.61
99510 - Photofinishing Worker	13.32
99710 - Recycling Laborer	15.75
99711 - Recycling Specialist	21.66
99730 - Refuse Collector	14.91
99810 - Sales Clerk	9.66
99820 - School Crossing Guard	16.75
99830 - Survey Party Chief	22.02
99831 - Surveying Aide	12.52
99832 - Surveying Technician	16.27
99840 - Vending Machine Attendant	22.67
99841 - Vending Machine Repairer	28.88
99842 - Vending Machine Repairer Helper	22.67

Note: Executive Order (EO) 13706 Establishing Paid Sick Leave for Federal Contractors applies to all contracts subject to the Service Contract Act for which the contract is awarded (and any solicitation was issued) on or after January 1 2017. If this contract is covered by the EO the contractor must provide employees with 1 hour of paid sick leave for every 30 hours they work up to 56 hours of paid sick leave each year. Employees must be permitted to use paid sick leave for their own illness injury or other health-related needs including preventive care; to assist a family member (or person who is like family to the employee) who is ill

injured or has other health-related needs including preventive care; or for reasons resulting from or to assist a family member (or person who is like family to the employee) who is the victim of domestic violence sexual assault or stalking. Additional information on contractor requirements and worker protections under the EO is available at www.dol.gov/whd/govcontracts.

ALL OCCUPATIONS LISTED ABOVE RECEIVE THE FOLLOWING BENEFITS:

HEALTH & WELFARE: \$4.54 per hour up to 40 hours per week or \$181.60 per week or \$786.93 per month

HEALTH & WELFARE EO 13706: \$4.22 per hour up to 40 hours per week or \$168.80 per week or \$731.47 per month*

*This rate is to be used only when compensating employees for performance on an SCA-covered contract also covered by EO 13706 Establishing Paid Sick Leave for Federal Contractors. A contractor may not receive credit toward its SCA obligations for any paid sick leave provided pursuant to EO 13706.

VACATION: 2 weeks paid vacation after 1 year of service with a contractor or successor; and 4 weeks after 3 years. Length of service includes the whole span of continuous service with the present contractor or successor wherever employed and with the predecessor contractors in the performance of similar work at the same Federal facility. (Reg. 29 CFR 4.173)

HOLIDAYS: A minimum of ten paid holidays per year: New Year's Day Martin Luther King Jr.'s Birthday Washington's Birthday Memorial Day Independence Day Labor Day Columbus Day Veterans' Day Thanksgiving Day and Christmas Day. (A contractor may substitute for any of the named holidays another day off with pay in accordance with a plan communicated to the employees involved.) (See 29 CFR 4.174)

THE OCCUPATIONS WHICH HAVE NUMBERED FOOTNOTES IN PARENTHESES RECEIVE THE FOLLOWING:

1) COMPUTER EMPLOYEES: Under the SCA at section 8(b) this wage determination does not apply to any employee who individually qualifies as a bona fide executive administrative or professional employee as defined in 29 C.F.R. Part 541. Because most Computer System Analysts and Computer Programmers who are compensated at a rate

not less than \$27.63 (or on a salary or fee basis at a rate not less than \$455 per week) an hour would likely qualify as exempt computer professionals (29 C.F.R. 541.400) wage rates may not be listed on this wage determination for all occupations within those job families. In addition because this wage determination may not list a wage rate for some or all occupations within those job families if the survey

data indicates that the prevailing wage rate for the occupation equals or exceeds \$27.63 per hour conformances may be necessary for certain nonexempt employees. For example if an individual employee is nonexempt but nevertheless performs duties within the scope of one of the Computer Systems Analyst or Computer Programmer occupations for which this wage determination does not specify an SCA wage rate then the wage rate for that employee must be conformed in accordance with the conformance procedures described in the conformance note included on this wage determination.

Additionally because job titles vary widely and change quickly in the computer industry job titles are not determinative of the application of the computer professional exemption. Therefore the exemption applies only to computer employees who satisfy the compensation requirements and whose primary duty consists of:

(1) The application of systems analysis techniques and procedures including consulting with users to determine hardware software or system functional specifications;

(2) The design development documentation analysis creation testing or modification of computer systems or programs including prototypes based on and related to user or system design specifications;

(3) The design documentation testing creation or modification of computer programs related to machine operating systems; or

(4) A combination of the aforementioned duties the performance of which requires the same level of skills. (29 C.F.R. 541.400).

2) AIR TRAFFIC CONTROLLERS AND WEATHER OBSERVERS - NIGHT PAY & SUNDAY PAY: If you work at night as part of a regular tour of duty you will earn a night differential and receive an additional 10% of basic pay for any hours worked between 6pm and 6am.

If you are a full-time employed (40 hours a week) and Sunday is part of your regularly scheduled workweek you are paid at your rate of basic pay plus a Sunday premium of 25% of your basic rate for each hour of Sunday work which is not overtime

(i.e. occasional work on Sunday outside the normal tour of duty is considered overtime work).

**** HAZARDOUS PAY DIFFERENTIAL ****

An 8 percent differential is applicable to employees employed in a position that represents a high degree of hazard when working with or in close proximity to ordnance explosives and incendiary materials. This includes work such as screening blending dying mixing and pressing of sensitive ordnance explosives and pyrotechnic compositions such as lead azide black powder and photoflash powder.

All dry-house activities involving propellants or explosives. Demilitarization modification renovation demolition and maintenance operations on sensitive ordnance explosives and incendiary materials. All operations involving re-grading and cleaning of artillery ranges.

A 4 percent differential is applicable to employees employed in a position that represents a low degree of hazard when working with or in close proximity to ordnance (or employees possibly adjacent to) explosives and incendiary materials which involves potential injury such as laceration of hands face or arms of the employee engaged in the operation irritation of the skin minor burns and the like; minimal damage to immediate or adjacent work area or equipment being used. All operations involving unloading storage and hauling of ordnance explosive and incendiary ordnance material other than small arms ammunition. These differentials are only applicable to work that has been specifically designated by the agency for ordnance explosives and incendiary material differential pay.

**** UNIFORM ALLOWANCE ****

If employees are required to wear uniforms in the performance of this contract (either by the terms of the Government contract by the employer by the state or local law etc.) the cost of furnishing such uniforms and maintaining (by laundering or dry cleaning) such uniforms is an expense that may not be borne by an employee where such cost reduces the hourly rate below that required by the wage

determination. The Department of Labor will accept payment in accordance with the following standards as compliance:

The contractor or subcontractor is required to furnish all employees with an adequate number of uniforms without cost or to reimburse employees for the actual cost of the uniforms. In addition where uniform cleaning and maintenance is made the responsibility of the employee all contractors and subcontractors subject to this wage determination shall (in the absence of a bona fide collective bargaining agreement providing for a different amount or the furnishing of contrary affirmative proof as to the actual cost) reimburse all employees for such cleaning and maintenance at a rate of \$3.35 per week (or \$.67 cents per day). However in those instances where the uniforms furnished are made of "wash and wear" materials may be routinely washed and dried with other personal garments and do not require any special treatment such as dry cleaning daily washing or commercial laundering in order to meet the cleanliness or appearance standards set by the terms

of the Government contract by the contractor by law or by the nature of the work there is no requirement that employees be reimbursed for uniform maintenance costs.

** SERVICE CONTRACT ACT DIRECTORY OF OCCUPATIONS **

The duties of employees under job titles listed are those described in the "Service Contract Act Directory of Occupations" Fifth Edition (Revision 1) dated September 2015 unless otherwise indicated.

** REQUEST FOR AUTHORIZATION OF ADDITIONAL CLASSIFICATION AND WAGE RATE Standard Form 1444 (SF-1444) **

Conformance Process:

The contracting officer shall require that any class of service employee which is not listed herein and which is to be employed under the contract (i.e. the work to be performed is not performed by any classification listed in the wage determination) be classified by the contractor so as to provide a reasonable relationship (i.e. appropriate level of skill comparison) between such unlisted classifications and the classifications listed in the wage determination (See 29 CFR 4.6(b)(2)(1)). Such conforming procedures shall be initiated by the contractor

GCC PR0049

prior to the performance of contract work by such unlisted class(es) of employees (See 29 CFR 4.6(b)(2)(ii)). The Wage and Hour Division shall make a final determination of conformed classification wage rate and/or fringe benefits which shall be paid to all employees performing in the classification from the first day of work on which contract work is performed by them in the classification. Failure to pay such unlisted employees the compensation agreed upon by the interested parties and/or fully determined by the Wage and Hour Division retroactive to the date such class of employees commenced contract work shall be a violation of the Act and this contract. (See 29 CFR 4.6(b)(2)(v)). When multiple wage determinations are included in a contract a separate SF-1444 should be prepared for each wage determination to which a class(es) is to be conformed.

The process for preparing a conformance request is as follows:

1) When preparing the bid the contractor identifies the need for a conformed occupation(s) and computes a proposed rate(s).

2) After contract award the contractor prepares a written report listing in order the proposed classification title(s) a Federal grade equivalency (FGE) for each proposed classification(s) job description(s) and rationale for proposed wage rate(s) including information regarding the agreement or disagreement of the authorized representative of the employees involved or where there is no authorized representative the employees themselves. This report should be submitted to the contracting officer no later than 30 days after such unlisted class(es) of employees performs any contract work.

3) The contracting officer reviews the proposed action and promptly submits a report of the action together with the agency's recommendations and pertinent information including the position of the contractor and the employees to the U.S. Department of Labor Wage and Hour Division for review (See 29 CFR 4.6(b)(2)(ii)).

4) Within 30 days of receipt the Wage and Hour Division approves modifies or disapproves the action via transmittal to the agency contracting officer or notifies the contracting officer that additional time will be required to process the request.

5) The contracting officer transmits the Wage and Hour Division's decision to the contractor.

6) Each affected employee shall be furnished by the contractor with a written copy of such determination or it shall be posted as a part of the wage determination (See

29 CFR 4.6(b)(2)(iii)).

Information required by the Regulations must be submitted on SF-1444 or bond paper.

When preparing a conformance request the "Service Contract Act Directory of Occupations" should be used to compare job definitions to ensure that duties requested are not performed by a classification already listed in the wage determination. Remember it is not the job title but the required tasks that determine whether a class is included in an established wage determination. Conformances may not be used to artificially split combine or subdivide classifications listed in the wage determination (See 29 CFR 4.152(c)(1))."

AFFIDAVIT RE CONTINGENT FEES

CITY OF _____)
) SS.
 ISLAND OF GUAM)

_____ [state name of affiant signing below], being first duly sworn, deposes and says that:

1. The name of the offering company or individual is [state name of company]
 _____.

2. As a part of the offering company's bid or proposal, to the best of my knowledge, the offering company has not retained any person or agency on a percentage, commission, or other contingent arrangement to secure this contract. This statement is made pursuant to 2 GAR Division 4 11108(f).

3. As a part of the offering company's bid or proposal, to the best of my knowledge, the offering company has not retained a person to solicit or secure a contract with the government of Guam upon an agreement or understanding for a commission, percentage, brokerage, or contingent fee, except for retention of bona fide employees or bona fide established commercial selling agencies for the purpose of securing business. This statement is made pursuant to 2 GAR Division 4 11108(h).

4. I make these statements on behalf of myself as a representative of the offeror, and on behalf of the offeror's officers, representatives, agents, subcontractors, and employees.

 Signature of one of the following:
 Offeror, if the offeror is an individual;
 Partner, if the offeror is a partnership;
 Officer, if the offeror is a corporation.

Subscribed and sworn to before me
 this ____ day of _____, 20____.

 NOTARY PUBLIC
 My commission expires _____, _____.

**Guam Community College
FIVE-YEAR ACADEMIC CALENDAR
AY2021-AY2022 – AY2025-AY2026**

REVISED

FALL TERM	2021	2022	2023	2024	2025
Faculty Start Date	8/9/2021	8/16/2022	8/14/2023	8/12/2024	8/11/2025
First Day of Monday-Wednesday Classes	8/11/2021	8/17/2022	8/16/2023	8/14/2024	8/13/2025
First Day of Tuesday-Thursday Classes	8/12/2021	8/16/2022	8/17/2023	8/16/2024	8/14/2025
First Day of Friday	8/13/2021	8/19/2022	8/18/2023	8/16/2024	8/15/2025
First Day of Saturday Classes	8/14/2021	8/20/2022	8/19/2023	8/17/2024	8/16/2025
Labor Day Holiday (Observed)	9/6/2021	9/6/2022	9/4/2023	9/2/2024	9/1/2025
All Soul's Day Holiday (Observed)	11/2/2021	11/2/2022	11/2/2023	11/1/2024	11/3/2025
Veteran's Day Holiday (Observed)	11/11/2021	11/11/2022	11/10/23 - 11/11/23	11/11/2024	11/11/2025
Thanksgiving Break	11/26/21 - 11/28/21	11/24/22 - 11/27/22	11/23/23 - 11/26/23	11/20/24 - 12/1/24	11/27/25 - 11/30/25
Our Lady of Camarín Day (Observed)	12/8/2021	12/8/2022	12/8/2023	12/8/2024	12/8/2025
Last Day of Monday-Wednesday Classes	11/24/2021	12/6/2022	11/29/2023	12/2/2024	12/1/2025
Last Day of Tuesday-Thursday Classes	12/2/2021	12/1/2022	12/6/2023	11/26/2024	12/2/2025
Last Day of Friday Classes	11/19/2021	12/9/2022	12/15/2023	12/6/2024	11/21/2025
Last Day of Saturday Classes	11/20/2021	12/3/2022	12/9/2023	11/23/2024	11/22/2025
Grades Due	12/7/2021	12/14/2022	12/20/2023	12/12/2024	12/6/2025
Potential Make-up Days	11/12, 11/19, 12/03	11/4, 11/18, 12/2	11/03, 11/17, 12/01	11/08, 11/16, 11/22	11/7, 11/14, 11/21
SPRING TERM	2022	2023	2024	2025	2026
Faculty Start Date	1/3/2022	1/9/2023	1/8/2024	1/6/2025	1/6/2026
First Day of Monday-Wednesday Classes	1/6/2022	1/11/2023	1/10/2024	1/8/2025	1/7/2026
First Day of Tuesday-Thursday Classes	1/6/2022	1/12/2023	1/11/2024	1/9/2025	1/8/2026
First Day of Friday Classes	1/7/2022	1/13/2023	1/12/2024	1/10/2025	1/9/2026
First Day of Saturday Classes	1/8/2022	1/14/2023	1/13/2024	1/11/2025	1/10/2026
Martin Luther King Jr. (Observed)	1/17/2022	1/16/2023	1/16/2024	1/20/2025	1/19/2026
Guam History & Chamorro Heritage Day - (Observed)	3/7/2022	3/6/2023	3/4/2024	3/3/2025	3/2/2026
Spring Break	4/11/22 - 4/17/22	4/3/23 - 4/9/23	3/26/24 - 3/31/24	4/14/25 - 4/20/25	3/30/26 - 4/5/26
Last Day of Monday-Wednesday Classes	6/2/2022	6/8/2023	6/6/2024	6/6/2025	6/4/2026
Last Day of Tuesday-Thursday Classes	4/26/2022	6/2/2023	4/30/2024	4/29/2025	4/28/2026
Last Day of Friday Classes	4/22/2022	4/28/2023	4/26/2024	4/26/2025	4/24/2026
Last Day of Saturday Classes	4/23/2022	4/29/2023	4/27/2024	4/26/2025	4/26/2026
Grades Due	6/8/2022	6/11/2023	6/9/2024	6/8/2025	6/7/2026
Commencement Exercises	6/13/2022	6/19/2023	6/17/2024	6/16/2025	6/16/2026
Memorial Day Holiday (Observed)	6/30/2022	6/29/2023	6/21/2024	6/26/2025	6/26/2026
Potential Make-up Days	4/8, 4/22, 4/29	4/14, 4/21, 4/28	4/12, 4/19, 4/26	4/4, 4/11, 4/26	4/10, 4/17, 4/24
SUMMER TERM	2022	2023	2024	2025	2026
Faculty Start Date / 1st Day of Classes	6/3/2022	6/2/2023	6/3/2024	6/3/2025	6/29/2026
Independence Day Holiday (Observed)	7/4/2022	7/4/2023	7/4/2024	7/4/2025	7/3/2026
Last Day of Classes	7/19/2022	7/14/2023	7/12/2024	7/11/2025	7/10/2026
Liberation Day Holiday (Observed)	7/21/2022	7/21/2023	7/22/2024	7/21/2025	7/21/2026
Grades Due (except Saturday classes)	7/20/2022	7/19/2023	7/17/2024	7/16/2025	7/16/2026
Potential Make-up Days	6/24, 7/1, 7/18	6/30, 7/7, 7/17	6/28, 7/6, 7/16	6/20, 6/27, 7/11	6/19, 6/26, 7/10

NOTES:

- 1) Satellite Program and cross-enrolled classes will follow the official Department of Education schedule for their respective schools. Professional Development Days as outlined in the GDOE Calendar will be utilized as working sessions, as needed.
- 2) Summer Term courses with more than 60 contact hours require additional class sessions.
- 3) Summer Saturday-only classes start the Saturday before the first day of weekday classes.
- 4) This Schedule is subject to change.

Mission Statement

Guam Community College is a leader in career and technical workforce development, providing the highest quality, student-centered education and job training for Micronesians. (Board of Trustees Policy 100)

Approved: _____

**Frank R. Arripia, Chairperson
Board of Trustees**

Date: **MAR 26 2021**

3/26/2021

GCC PR0053

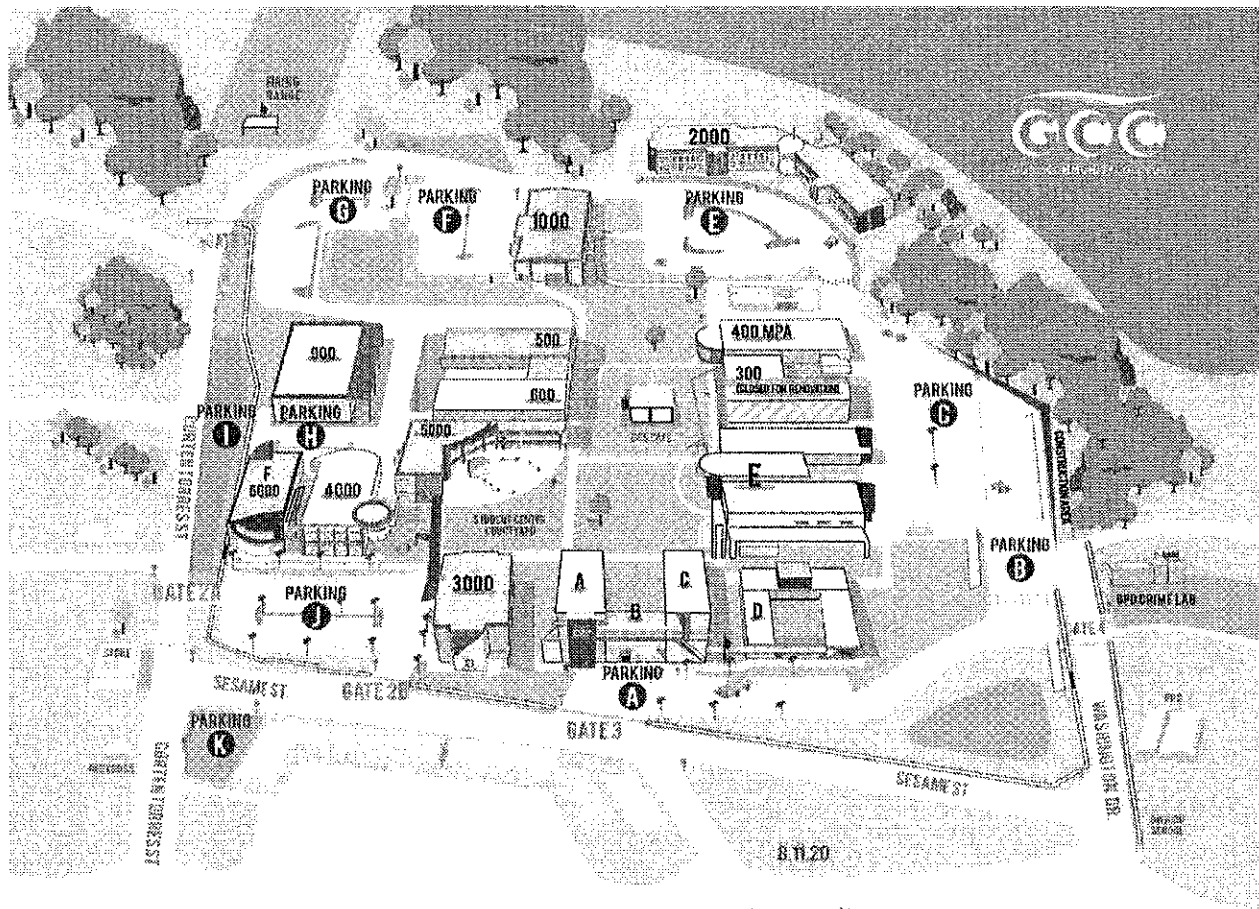

A	Classrooms, Criminal Justice Office	500	Automotive Classroom/Shop, Automotive Technology Office
B	Student Support Services, Student Success Lab	600	Construction Classroom/Workshop, Maintenance Dept.
C	Classrooms	900	Autobody/Welding Shop/Classrooms, Construction Trades Office
D	Classrooms, Computer Science Office, Management Information Systems (MIS)	1000	Technology Center: Classrooms, Study Hall, Mac Lab, Electronics Lab, Offices, VisCom Studio, Test Center
E	Classrooms, Study Hall, Workout Room, Criminal Justice Offices, Developmental Education, Education/English Offices, AutoCAD Labs, Mansana Center	2000	Student Services & Administration: Admissions & Registration, Financial Aid, Cashier, Counseling, Accommodative Services, Continuing Ed., Business Office, Administrative Offices
F	Foundation Building (6000) Classrooms, Bookstore, Café, Adult Ed. Office, Veterans Study Room	3000	Anthony A. Leon Guerrero Allied Health Center: Classrooms, Lecture Halls
300	CLOSED FOR RENOVATION	4000	Learning Resource Center (LRC) - Library: Computer Lab
400	Multipurpose Auditorium (MPA) Culinary Arts Kitchen & Office	5000	Student Center: Student Lounge, Computer Lab, Training Room, Health Services Center, Center for Student Involvement, Reach for College, Project AIM/TRIO Program, Academic Advisement & Career Placement

Government of Guam

Holidays

§1000 (a) Chapter 10 of Title 1 GCA
As amended by PL 32-145

1. New Year's Day, January 1
2. Martin Luther King, Jr., third Monday in January
3. Guam History & Chamorro Heritage Day, first Monday in March
4. Memorial Day, the last Monday in May
5. Independence Day, July 4
6. Liberation Day, July 21
7. Labor Day, the first Monday in September
8. All Soul's Day, November 2
9. Veteran's Day, November 11
10. Thanksgiving Day, the fourth Thursday in November
11. Our Lady of Camarin Day, December 8
12. Christmas Day, December 25

§1000 (b) Chapter 10 of Title 1 GCA states in part.... "Whenever a holiday falls on a Saturday or Sunday, the government of Guam shall follow the federal government's practice for that holiday." (c) In addition to the holidays specified in Subsection (a) of this Section, I Maga'láhen Guåhan may declare by Executive Order additional non-permanent holidays for special purposes. No holiday declared by Executive Order shall be continued beyond the year in which the Executive Order is issued.

Updated: 11/14/2014



GCC Bid No:
GCC-FB-21-009

Bid Description:
Replacement of Building 900
Metal Awning Structure

May 2021

Page 1 of 7

Guam Community College (GCC) is soliciting the service of a qualified contractor to replace the dilapidated awning structure located at building 900 and including (but not limited to) the following.

SCOPE OF WORK (SOW):

A. General Requirements of the Scope of Work:

The Qualified Contractor for this SOW shall:

1. Conduct a holistic assessment, verify existing conditions, and conduct all the necessary work for a design build concept to replace the dilapidated awning located at building 900 to include all component elements for complete functionality, operation, safety and code-compliance (i.e., civil, mechanical, infrastructure, etc.).
2. Provide contractual services to include at a minimum the following component elements – assessment, estimation, replacement requirements, certification, and as-build drawings
3. Ensure “good standings” with governing authorities having jurisdiction with the SOW (e.g., Guam Department of Public Works, Department of Revenue and Taxation, Guam Contractor’s License Board, etc.) prior to commencing work related to this SOW.
4. When appropriate, obtain and pay requisite permits, clearances, and approvals, from all applicable government of Guam agencies.
5. A **mandatory** site visit is scheduled for 10:00 a.m. at the project site on **Wednesday, May 19, 2021.** Contact Josephine Arceo at 735-5521 if accommodative service or an additional site visit is needed.
6. Warranty: Qualified Contractor shall assure against defective materials and workmanship by providing a one (1) year written Certificate of Warranty. The Certificate of Warranty shall commence immediately upon GCC’s explicit acceptance of the project. The Certificate of Warranty shall honor all product warranties and include the cost of all parts, workmanship, and related labor fees. Qualified Contractor must provide and honor all written product warranties.
7. When awarded, the Qualified Contractor shall submit a list and have all supplies and materials for GCC’s explicit approval prior to their use or installation. All supplies, materials, and incidentals included in this SOW shall be new and of the most suitable grade for the purpose intended.
8. Qualified Contractor’s employees assigned to this project shall be cleared from the Guam Sex Offender Registry and have a GCC badge clearly visible on his/her person.



**GCC Bid No:
GCC-FB-21-009**

**Bid Description:
Replacement of Building 900
Metal Awning Structure**

May 2021

Page 2 of 7

9. The Qualified Contractor shall conform to all Occupational Safety and Health Administration (OSHA) regulations, the National Electrical Code (NEC), Environmental Protection Agency and the National Fire Protection Association (NFPA). Clean, maintain, protect work site, and newly installed work as necessary throughout the project period. Provide suitable protective covering on newly installed work when reasonably required to mitigate damage (e.g., during inclement weather) until such time the project is accepted by GCC. Before commencing work, the Qualified Contractor shall coordinate and have in place necessary provisions to protect adjacent building properties for safety, to minimize disruptions and prevent ANY potential hazards. For example, relocate contents away from immediate work area to unoccupied location as work requirements dictate.
10. Properly dispose and recycle all waste, debris, rubbish, etc. associated with the project legally and off-site. Do not allow debris to accumulate at the project site.
11. Take all precautions to assure that GCC's stakeholders (students, employees, and visitors) remain out of harm's way throughout the project. The Qualified Contractor shall properly block off the project site and use appropriate signage.
12. GCC's hours of operation is Monday through Thursday, 7:30 a.m. to 10 p.m., Friday from 7:30 a.m. to 6:00 pm, and Saturday from 7:30 a.m. to 12 p.m. GCC also recognizes Government of Guam's holidays. The Qualified Contractor's request to work on campus outside of GCC's hours of operation must be preapproved by Planning and Development Department.
13. The Qualified Contractor and her/his employees shall adhere to GCC's Tobacco and Betel Nut (Pugu'a) Free Policy 175:
 - a. DO NOT use tobacco products while on Guam Community College property.
 - b. DO NOT use electronic cigarette (e-cigs) devices while on Guam Community College property.
 - c. DO NOT chew or spit pugu'a or chewing tobacco while on Guam Community College property.
14. The Qualified Contractor and her/his employees shall adhere to Public Health and GCC's COVID19 guidelines on campus at all times;
15. Correct defective work to meet SOW requirements.
16. The project is deemed complete by the Qualified Contractor's submission of all warranties, as-build, GCC's formal inspection, and GCC's acceptance of the project for its intended use.



**GCC Bid No:
GCC-FB-21-009**

**Bid Description:
Replacement of Building 900
Metal Awning Structure**

May 2021

Page 3 of 7

17. Submit a price proposal having an itemized cost such that GCC may award the project based on the "...lowest, most responsive..." price proposal based on the Scope of Work and related requirements (A. General Requirements of the Scope of Work and B. Specific Requirements of the Scope of Work).

18. Qualified Contractor shall deliver a complete price proposal packet to include the following (18a-18e):

- a. A Narrative (required document) describing how the Qualified Contractor will address this project's SOW;
- b. A Critical Path Method (CPM) chart (required document) to illustrate the Qualified Contractor's timeline to complete the project within ninety (90) consecutive calendar days upon receipt of a purchase order and inclusive of the building permit process and material lead-time;
- c. Submission of a conceptual design illustrating the size and design of the awning.
- d. Submission of Bid (with required documents): one original and two complete copies; and
- e. **Cost breakdown for:**

1. Building 900 Awning Bid Price Sheet:

Description of Work	Cost for Supplies, Materials, etc..	Cost for Labor	Total
a. Removal and disposal of the existing awning. (i.e. Corrugated roof sheet panels, purlins, rafters, etc...)			
b. Removal and disposal of the existing metal columns and beams			
c. Installation of new metal columns and beams (Option 1 for Black Iron and Option 2 for Galvanized)			
d. Installation of cable bracing at three (3) specific locations			
e. Installation of new Purlins, S-layer and 2'-6" overlap including all component elements			
f. Installation of new rafter system including all component elements			



**GCC Bid No:
GCC-FB-21-009**

**Bid Description:
Replacement of Building 900
Metal Awning Structure**

May 2021

Page 4 of 7

g. Installation of 22 gauge thickness corrugated roof sheet panels to include roof sealant for fastener and joint protection and leak prevention.			
h. Application of oil based primer and two (2) coats final paint on corrugated roof sheet panels (top and bottom)			
i. Removal and reinstallation of additional tools, equipment, infrastructure, etc... into the new awning structure.			
Total Project Bid Price			

- e. Submit ALL required documents (A. General Requirements of the Scope of Work (SOW) and B. Technical Specifications of the SOW), before **June 03, 2021** to:

Joleen Evangelista, Procurement & Inventory Administrator
 Materials Management Office
 Guam Community College
 One Sesame Street
 Student Services and Administration Building, Room 2105
 Mangilao, Guam 96913

18. GCC shall be indemnified for any under-estimations / oversights attributed to the Qualified Contractor's lack of due diligence or wrongful assumptions.

B. Technical Specifications:

1. Awning: The new awning design shall be identical to the existing awning system at building 900.
 - a. Removal and disposal of existing metal awning to include sheet panels, purlins, rafters and all component elements;
 - b. Removal and disposal of existing metal columns and beams;
 - c. Installation of new metal columns and beams with oil-based primer and two (2) coat final paint;
 - d. Installation of cable bracing at 3 specific locations;
 - e. Installation of purlins S-layer and 2'-6" overlap;
 - f. Installation of rafter system;
 - g. Installation of 22-gauge thickness corrugated roof sheet panels
 - h. Installation of gutter and downspout.
 - i. Removal and reinstallation of additional tools, equipment, infrastructure, etc... that were a part of the original awning structure (to be determined by Program Deans, Department Chairs and Faculty);
2. The Qualified Contractor shall ensure the new awning structure shall be properly and securely integrated into the building 900 structure;



GCC Bid No:
GCC-FB-21-009

Bid Description:
Replacement of Building 900
Metal Awning Structure

May 2021

Page 5 of 7

3. The Qualified Contractor shall ensure the use of only anti-corrosive fasteners, nuts, bolts, etc... and no metal to metal corrosion reactions as a result of two different metals being in contact;
4. The Qualified contractor shall ensure absolutely no leaks at any point of the new awning structure roof;
5. The Qualified Contractor shall ensure the structure is engineered to withstand maximum sustained winds of 200 miles-per hour.
6. Refer to the attached Exhibit #1

[GUAM COMMUNITY COLLEGE-BUILDING 900 METAL AWING]

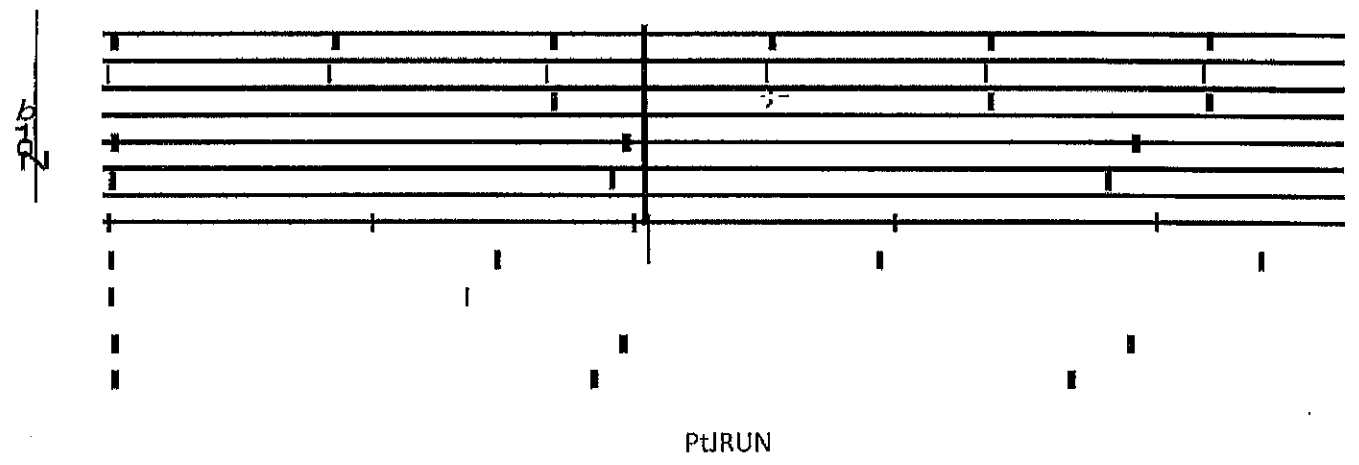
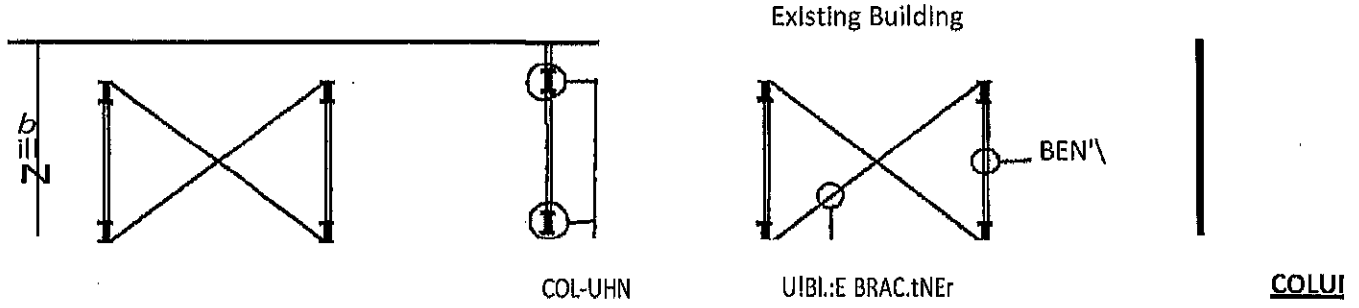
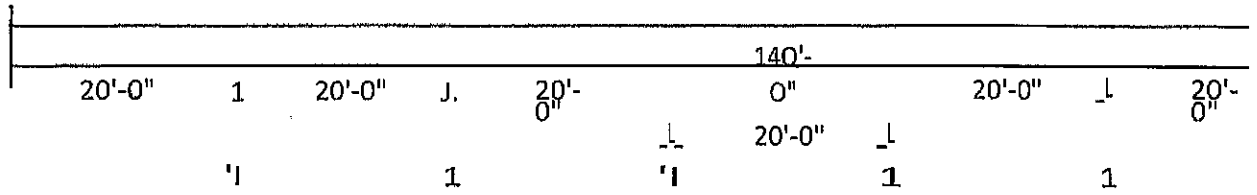

Handwritten notes on the left margin, including the number '27' and some illegible text.

ROOF PURLIN PLAN



ROOF SHEETING PLAN

ROOFSHEET N"EL

L-GUTTER/DOWN SPOUT

27

Procurement Appeal No. OPA-PA-21-013

Procurement Record
Tab 4

GUAM COMMUNITY COLLEGE

BID PACKET (PICK-UP) Sign in Sheet

Date: May 13, 2021

Bid No.: GCC-FB-21-009

Bid Description: Replacement of Building 900 Metal Awning Structure

VENDORS please provide all contact information requested
PRINT CLEARLY & LEGIBLY

PDF Request Via Email	Vendor Name & Address PRINT CLEARLY & LEGIBLY	Representative Name & E-Mail Address	Telephone Number & Fax Number	Date & Cashier Receipt / Inv. No.
PDF Request 5/13/21 Sent 5/13/21	Vendor Name: Paradise Awning Vendor Mailing Address: P.O. Box 6128 Taming, Guam 96931 Vendor Name: Murphy Eng. Inc. Vendor Mailing Address: 275-G Forendt Ave STE 228 Taming, Guam, 96913	Full Name: Kovina Yoo E-Mail Address: Sales@getintheshade.com Full Name: Luke Murphy E-Mail Address: lukemurphy@gmail.com	Telephone Number: 649-3991 Fax Number: 649-3990 Telephone Number: 787-0542 Fax Number:	Date: 5-17-21 Cashier Receipt / Inv. No.: 131998
PDF Request 5/13/21 Sent 5/13/21	Vendor Name: USA Contractors Inc. Vendor Mailing Address: 138 Kayer chando st. Dededo, Guam 96929	Full Name: Eddie Oropay E-Mail Address: sales@usacontractors.com	Telephone Number: 632-3044 Fax Number: 632-9000	Date: 5/14/21 Cashier Receipt / Inv. No.:
PDF Request 5/17/21 Sent 5/17/21	Vendor Name: J.T Global Services Vendor Mailing Address:	Full Name: Ambros M. Rokop E-Mail Address: ambros.vokop@jiglobal.com	Telephone Number: 622-1179 Fax Number: 622-3880	Date: 5/19/21 Cashier Receipt / Inv. No.: 132014
PDF Request 5/13/21 Sent 5/13/21	Vendor Name: Clavarch Vendor Mailing Address: P.O. Box 1244 Taming, Guam	Full Name: Hak Jay Kim E-Mail Address: admin@clavarch.com	Telephone Number: 622-92 Fax Number:	Date: 5/19/21 Cashier Receipt / Inv. No.: 132014

GUAM COMMUNITY COLLEGE

BID PACKET (PICK-UP) Sign in Sheet

Date: May 13, 2021

Bid No.: GCC-FB-21-009

Bid Description: Replacement of Building 900 Metal Awning Structure

VENDORS please provide all contact information requested
PRINT CLEARLY & LEGIBLY

PDF Request Via Email	Vendor Name & Address PRINT CLEARLY & LEGIBLY	Representative Name & E-Mail Address	Telephone Number & Fax Number	Date & Cashier Receipt / Inv. No.
✓	Vendor Name <i>Paradise Awning</i>	Full Name <i>Alexander Au-Yang</i>	Telephone Number <i>699-3991</i>	Date <i>5/19/21</i>
6	Vendor Mailing Address <i>P.O. Box 6128 Tamuning</i>	E-Mail Address <i>Sales @getthefirstnode.com</i>	Fax Number	Cashier Receipt / Inv. No. <i>132019</i>
7	Vendor Name <i>JJ GLOBAL</i>	Full Name <i>AARON BUEGGER</i>	Telephone Number <i>632-1179</i>	Date <i>5/19/21</i>
	Vendor Mailing Address <i>Industrial 215 ROUTE 5 Streets, Harmon Park, Tamuning, GU. 96913</i>	E-Mail Address <i>aileen @jiglobal.com</i>	Fax Number	Cashier Receipt / Inv. No. <i>132020</i>
8	Vendor Name	Full Name	Telephone Number	Date
	Vendor Mailing Address	E-Mail Address	Fax Number	Cashier Receipt / Inv. No.
9	Vendor Name	Full Name	Telephone Number	Date
	Vendor Mailing Address	E-Mail Address	Fax Number	Cashier Receipt / Inv. No.
10	Vendor Name	Full Name	Telephone Number	Date
	Vendor Mailing Address	E-Mail Address	Fax Number	Cashier Receipt / Inv. No.



(Pdf Req.)
Patricia Palacios <patricia.palacios@guamcc.edu>

Bid Packet Request GCC-FB-21-009

1 message

Korina Yoo <korinay@getintheshade.com>
To: materialsmanagement@guamcc.edu
Cc: "sales getintheshade.com" <sales@getintheshade.com>

Thu, May 13, 2021 at 2:10 PM

Hello,

My name is Korina Yoo and I'm reaching out on behalf of Paradise Awning to kindly request a digital copy of the bid packet for GCC-FB-21-009 Replacement of Building 900 Metal Awning Structure.

We appreciate your assistance.

All the best,

Korina Yoo

Sales Executive



Get in the Shade!

sales@getintheshade.com

P.O. Box 6128

Tamuning, Guam 96931

T: (671) 649-3991

F: (671) 649-3990



E-mail administered by Guam Community College

GCC PR0066

Joleen Evangelista

(acknowledgment)
PDF REQ.

From: Korina Yoo <korinay@getintheshade.com>
Sent: Friday, May 14, 2021 9:13 AM
To: 'Patricia Palacios'
Cc: 'Guam Community College'; 'Benson Au-Yeung'; 'Alex'; 'sales@getintheshade.com'
Subject: RE: Request for PDF Bid Packet

Hello Patricia,

Thank you for the bid packet. We will be sending our representatives (see below) to the Mandatory Pre-bid Conference & Site Visit on Wednesday, May 19, 2021:

1. Benson Au-Yeung, President/General Manager
2. Alexander Au-Yeung, Operations Manager

If there is anything else they need to bring or be aware of apart from the \$25 bid packet fee, please let me know.

All the best,
Korina Yoo
Sales Executive



From: Patricia Palacios <patricia.palacios@guamcc.edu>
Sent: Thursday, May 13, 2021 3:45 PM
To: korinay@getintheshade.com
Cc: Guam Community College <materialsmanagement@guamcc.edu>
Subject: Request for PDF Bid Packet

Attn: Prospective Bidder,

Thank you for your interest in participating in GCC's bidding process. Per your request attached is the PDF file for GCC-FB-21-009 - Replacement of Building 900 Metal Awning Structure.

Please note: Should you decide on submitting a bid packet, please ensure that the non-refundable bid package fee of \$25.00, must be paid on or by the Mandatory Pre-bid Conference & Site Visit.

Please Note: NO late packages will be accepted

Thank You,



RIF Rea.
Patricia Palacios <patricia.palacios@guamcc.edu>
JIT Global

Request for PDF

1 message

Patricia Palacios <patricia.palacios@guamcc.edu>
To: ambros.rokop@jitglobal.services
Cc: Guam Community College <materialsmanagement@guamcc.edu>

Mon, May 17, 2021 at 12:18 PM

Attn: Prospective Bidder,

Thank you for your interest in participating in GCC's bidding process. Per your request attached is the PDF file for GCC-FB-21-009 - Replacement of Building 900 Metal Awning Structure.

Please note: Should you decide on submitting a bid packet, please ensure that the non-refundable bid package fee of \$25.00, must be paid on or by the Mandatory Pre-bid Conference & Site Visit.

Please Note: NO late packages will be accepted

Thank You,

Patricia U. Palacios

Buyer II

Materials Management Office

materialsmanagement@guamcc.edu

Tel: 735-5540/5542

 Bid Packet - GCC-FB-21-009.pdf
1472K

GCC PR0069



(PdF Rea.)
Patricia Palacios <patricia.palacios@guamcc.edu>

bid inquiry

1 message

Ambros Mori Rokop Jr. <ambros.rokop@jjglobal.services>
To: materialsmanagement@guamcc.edu

Sat, May 15, 2021 at 8:12 AM

Good morning,

I am Ambros from JJ Global,

I would like to inquire on how to obtain a bid packet

For bid no:GCC-FB-21-009

Thank you

Best regards

Si Yu'os Ma'åse'

Best regards,

Ambros M. Rokop
Admin. Assistant
JJGlobal Services
C website: <http://www.jjglobal.services/>
E: ambros.rokop@jjglobal.service
T: 632-1179
F:632-3550



E-mail administered by Guam Community College

GCC PR0070



(PDF Req.)
Patricia Palacios <patricia.palacios@guamcc.edu>
USA Cont.

Request for PDF
1 message

Patricia Palacios <patricia.palacios@guamcc.edu>
To: USA Contractors Corporation <sales@usacontractorscorp.com>
Cc: Guam Community College <materialsmanagement@guamcc.edu>

Mon, May 17, 2021 at 12:15 PM

Attn: Prospective Bidder;

Thank you for your interest in participating in GCC's bidding process. Per your request attached is the PDF file for GCC-FB-21-009 - Replacement of Building 900 Metal Awning Structure.

Please note: Should you decide on submitting a bid packet, please ensure that the non-refundable bid package fee of \$25.00, must be paid on or by the Mandatory Pre-bid Conference & Site Visit.

Please Note: NO late packages will be accepted

Thank You,

Patricia U. Palacios

Buyer II

Materials Management Office

materialsmanagement@guamcc.edu

Tel: 735-5540/5542

 Bid Packet - GCC-FB-21-009.pdf
1472K



(Pdf Req.)
Patricia Palacios <patricia.palacios@guamcc.edu>

GCC-FB-21-009

1 message

USA Contractors Corporation <sales@usacontractorscorp.com>

Fri, May 14, 2021 at 3:36 PM

To: "materialsmanagement@guamcc.edu" <materialsmanagement@guamcc.edu>, Joleen Evangelista

<joleen.evangelista@guamcc.edu>

Cc: Jose Marimla <jose.marimla@medpharmusa.net>

Hafa Adai Ms. Joleen,

Good afternoon. May I kindly request for a soft copy of the bid package for review purposes. I look forward to your response. Thank you.

Eddie Onopey

Sales Representative

Cell No. (671) 727-8700

E-mail. sales@usacontractorscorp.com



CONTRACTORS INC.

138 Kayen Chando St. Dededo GU 96929

Tel. 671.632.3044 Fax. 671.632.9000

CONFIDENTIALITY: This email message contains confidential, privileged information and is for the sole use of the intended recipient(s) authorized by MedPharm. Any unauthorized review, use, disclosure or distribution of this email and attachment is prohibited. If you are not the intended recipient, please contact the sender by return email and destroy all paper and electronic copies of the original message.



E-mail administered by Guam Community College

bid_advertisement_-_gcc-fb-21-009.pdf
26K

GCC PR0072



Request for BIF
Patricia Palacios <patricia.palacios@guamcc.edu>
ClayArch Inc

Bid Advertisement - GCC-FB-21-009

3 messages

Patricia Palacios <patricia.palacios@guamcc.edu> Tue, May 18, 2021 at 5:59 PM
To: Clayarch Inc <admin@clayarchinc.com>, operations@orlon-guam.com, dhbme@bmesons.com
Cc: Guam Community College <materialsmanagement@guamcc.edu>

Hafa Adai,

If you are interested, attached is the bid advertisement for Bid No. GCC-FB-21-009, Replacement of Building 900 Metal Awning Structure.

Please note if interested the Mandatory Pre-Bid Conference & Site Visit is scheduled for tomorrow, 10:00 am., Wednesday, May 19, 2021 at Technology Center, Building 1000, Room 1107.

If interested Bid Packets must be purchased by 4:00 pm, Wednesday, May 19, 2021. See bid advertisement attached.

Thank You,

Patricia U. Palacios

Buyer II

Materials Management Office

materialsmanagement@guamcc.edu

Tel: 735-5540/5542

Bid Advertisement - GCC-FB-21-009.pdf
26K

admin@clayarchinc.com <admin@clayarchinc.com>
To: Patricia Palacios <patricia.palacios@guamcc.edu>

Wed, May 19, 2021 at 12:12 PM

Hello, Patricia,

Could you please send me the bid packet for GCC-FB-21-009?

Thank you so much.

Best regards,

MIN CHUL KONG



SBA 8(a), HUBZone Certified Small Business

T (671) 646-8842 C (671) 486-8290

admin@clayarchinc.com

mckong@clayarchinc.com

www.clayarchinc.com

P.O.Box 12577 Tamuning, Guam 96931

Suite 206 Oka Plaza No.202 Farenholt Ave.

Tamuning, Guam 96913

[Quoted text hidden]



E-mail administered by Guam Community College

Patricia Palacios <patricia.palacios@guamcc.edu>
To: Clayarch Inc <admin@clayarchinc.com>
Cc: Guam Community College <materialsmanagement@guamcc.edu>

Wed, May 19, 2021 at 3:02 PM

Attn: Prospective Bidder,

Thank you for your interest in participating in GCC's bidding process. Per your request attached is the PDF file for GCC-FB-21-009 - Replacement of Building 900 Metal Awning Structure.

Please note: Should you decide on submitting a bid packet, please ensure that the non-refundable bid package fee of \$25.00, must be paid on or by the Mandatory Pre-bid Conference & Site Visit.

Please Note: NO late packages will be accepted

Thank You,

Patricia U. Palacios

Buyer II

Materials Management Office

GCC PR0074

materialsmanagement@guamcc.edu

Tel: 735-5540/5542

[Quoted text hidden]

 Bid Packet - GCC-FB-21-009.pdf
1472K

Procurement Appeal No. OPA-PA-21-013

Procurement Record
Tab 5



Patricia Palacios <patricia.palacios@guamcc.edu>

Pre-Bid Conference Minutes

1 message

Patricia Palacios <patricia.palacios@guamcc.edu>

To: Clayarch Inc <admin@clayarchinc.com>, sales@getintheshade.com, ea_lbco@yahoo.com, Aileen de Dios <aileen@jglobal.services>, Jerome uson@jglobal.services, craigbascon77@gm

Cc: Guam Community College <materialsmanagement@guamcc.edu>, Francisco Palacios <francisco.palacios1@guamcc.edu>, Inocencio SanAgustin <inocencio.sanagustin@guamcc.edu>

To All Prospective Bidders,

Attached is the Pre-Bid Conference Minutes for GCC-FB-21-009, Replacement of Building 800 Metal Awning Structure..

Please acknowledge receipt of this email no later than 5:00 pm, Friday, May 21, 2021.

Thank You,

Patricia U. Palacios

Buyer II

Materials Management Office

materialsmanagement@guamcc.edu

Tel: 735-5540/5542

 Pre-Bid Conference Minutes.pdf
39K

GCC PR0076

GUAM COMMUNITY COLLEGE

PRE-BID CONFERENCE NOTES

Bid No.: **GCC-FB-21-009**

Bid Description: Replacement of Building 900 Metal Awning Structure

Attendance:

Guam Community College: Joleen Evangelista (MMO), Patricia Palacios (MMO), Francisco Palacios (P&D), Inocencio San Agustin (P&D)

Vendors:

ClayArch Inc.; Hak Jung Kim, Min Chul Kong, Paradise Awning; Alex Au-Yeaung, Top Builders, LLC; Edwin Aclan, JJ Global Services; Aaron Burger, Jerome Uson, Craig Uson

Meeting called to order by Joleen Evangelista, MMO @ 10:00 a.m. Introductions conducted.

Procurement Requirements: This is the Mandatory Pre-Bid Conference & Site Visit for GCC-FB-21-009– Prospective Bidders must be in present attendance at the pre-bid conference and pay the \$25.00 fee by 4:00 pm today, in order to qualify for the bid. Prospective bidder must submit an original and two copies of the bid in a sealed envelope and can be submitted prior to 10:00 a.m., Thursday, June 3, 2021. No Late Bids are accepted. Bid Packets must be dated and stamp by Materials Management Office. Any questions asked must be in writing and submitted to materialsmanagement@guamcc.edu no later than Thursday, May 20, 2021, 5:00 p.m. Also, acknowledgement of receipt of the amendment is required via email or fax. If you send the questions by fax please call MMO to ensure we received the questions. Please acknowledge indicating your company name & contact person, address & Amendment number on the email. The deadline for GCC to response to the questions is Tuesday, May 25, 2021 by 5:00pm. Required delivery date is 90 Calendar Days upon receipt of the purchase order/contract to include building permit process and material lead time.

A Bid Guarantee of (15% of bid amount) is required it may be in a form of a Cashier's check, letter of credit, surety bond with the certificate of authority, & power of attorney. Brochures/Descriptive Literature/Technical Specifications, Project Narrative, CPM Chart, Conceptual Design. A performance bond is required for this bid. Affidavit Disclosing Ownership and Commissions; Other Affidavits: Non-Collusion, Gratuities and Kickbacks, Ethical Standards and Contingent Fees, all affidavits must be notarized. U. S. Department of Labor Wage Determination (please see instructions in the form however, GCC provided the wage listing in the Bid Packet that must be submitted with the DOL wage form. Also attached to the bid packet is the Government of Guam Holidays, GCC Campus Map and the 5 Year Academic Calendar. Prospective Bidders must acknowledge pre-bid minutes and any Addendums Issued by the GCC Materials Management Office; Upon bid award the successful bidder must provide a current Guam Business License expiring 2021 or 2022. All documents required in the bid must be submitted. Failure to comply with the requirements will be basis of non-selection/disqualification and rejection of the bid. Testing on the structure was done and came back negative, no asbestos or lead found.

Scope of Work Requirements: Guam Community College (GCC) is soliciting the service of a qualified contractor to replace the dilapidated awning structure located at building 900.

Questions:

1. Does GCC need two prices for Galvanize Steel? – JJ Global Services - Yes, you need a price for Option 1 and Option 2-two separate line items.

> 5:00 p.m., Thursday, May 20, 2021 - Deadline for Questions

> 5:00 p.m., Tuesday, May 25, 2021 - Deadline for GCC Response to Questions

> 10:00 a.m., Thursday, June 3, 2021 - Bid Opening. Bidders may submit packages a day before to avoid rushing. No late bids will be accepted. Bidders are welcome but not a requirement to attend the bid opening; however, your bid packet must be submitted before this time. No late packets will be accepted. Today at 4:00pm is the deadline to purchase a bid packet.

Meeting adjourned: 10:22 a.m.

Transcribed by: *Patricia U. Palacios, MMO*

GCC PR0077



(Paradise Awning)

Patricia Palacios <patricia.palacios@guamcc.edu>

PBCM

Pre-Bid Conference Minutes

4 messages

Patricia Palacios <patricia.palacios@guamcc.edu>

To: Clayarch Inc <admin@clayarchinc.com>, sales@getinthesshade.com, ea_ubgc@yahoo.com, Alison de Dios <alison@jglobal.services>, Jerome uson@jglobal.services, craigbascon77@gmail.com
Cc: Guam Community College <materialsmanagement@guamcc.edu>, Francisco Palacios <francisco.palacios1@guamcc.edu>, Inocencio SanAgustin <inocencio.sanagustin@guamcc.edu>

To All Prospective Bidders,

Attached is the Pre-Bid Conference Minutes for GCC-FB-21-009, Replacement of Building 900 Metal Awning Structure..

Please acknowledge receipt of this email no later than 5:00 pm, Friday, May 21, 2021.

Thank You,

Patricia U. Palacios

Buyer II

Materials Management Office

materialsmanagement@guamcc.edu

Tel: 735-5540/5542

Pre-Bid Conference Minutes.pdf
39K

(PBCM)

ClayArch Inc

admin@clayarchinc.com <admin@clayarchinc.com>
To: Patricia Palacios <patricia.palacios@guamcc.edu>
Cc: materialsmanagement@guamcc.edu

Thu, May 20, 2021 at 11:07 PM

Hello, Patricia,

Please see attached acknowledged receipt of Pre-Bid Conference Minutes for GCC-FB-21-009.

Thank you.

Best regards,

MIN CHUL KONG



SBA 8(a), HUBZone Certified Small Business

T (671) 646-9842 C (671) 486-8290

admin@clayarchinc.com

mckong@clayarchinc.com

www.clayarchinc.com

P.O.Box 12577 Tamuning, Guam 96931

Suite 208 Oka Plaza No.202 Farenholt Ave.

Tamuning, Guam 96913

[Quoted text hidden]



E-mail administered by Guam Community College

GCC PR0078

Patricia Palacios <patricia.palacios@guamcc.edu>
To: Clayarch Inc <admin@clayarchinc.com>
Cc: Guam Community College <materialsmanagement@guamcc.edu>

Thu, May 20, 2021 at 11:36 PM

Received, thank you.
[Quoted text hidden]

2 attachments



(PBM) Paradise Awning

Korina Yoo <korinay@getintheshade.com>
To: Patricia Palacios <patricia.palacios@guamcc.edu>, Guam Community College <materialsmanagement@guamcc.edu>, francisco.palacios1@guamcc.edu, innocencio.sanagustin@guamcc.edu
Cc: "sales getintheshade.com" <sales@getintheshade.com>

Fri, May 21, 2021 at 8:19 AM

Hello,

Confirming receipt. Thank you.

All the best,

Korina Yoo

Sales Executive



From: sales getintheshade.com <sales@getintheshade.com>
Sent: Thursday, May 20, 2021 5:52 PM
To: korinay getintheshade.com <korinay@getintheshade.com>
Subject: FW: Pre-Bid Conference Minutes

From: Patricia Palacios <patricia.palacios@guamcc.edu>
Sent: Thursday, May 20, 2021 7:52:06 AM (UTC+00:00) Monrovia, Reykjavik
To: Clayarch Inc <admin@clayarchinc.com>; sales getintheshade.com <sales@getintheshade.com>; ea_tbgc@yahoo.com <ea_tbgc@yahoo.com>; Alleen de Dios <alleen@jglobal.services>; jerome.uson@jglobal.services <jerome.uson@jglobal.services>; craigbascon77@gmail.com <craigbascon77@gmail.com>
Cc: Guam Community College <materialsmanagement@guamcc.edu>; Francisco Palacios <francisco.palacios1@guamcc.edu>; Innocencio SanAgustin <Inocencio.sanagustin@guamcc.edu>
Subject: Pre-Bid Conference Minutes

[Quoted text hidden]



[Quoted text hidden]



JJ Global
Patricia Palacios <patricia.palacios@guamcc.edu>
PBM

Acknowledgement of Bid

1 message

Ambros Mori Rokop Jr. <ambros.rokop@jjglobal.services>

Fri, May 21, 2021 at 4:40 PM

To: "patricia.palacios" <patricia.palacios@guamcc.edu>

Cc: Aileen de Dios <aileen@jjglobal.services>, Kit Casin <kit.casin@jjglobal.services>

Good evening Patricia,
I hope this email finds you well.
We acknowledge the bid and signed as shown in the attached file
Attached below.

Should you need further assistance please do not hesitate to contact us.

Thank you

Si Yu'os Ma'åse'

Best regards,

Ambros M. Rokop
Admin. Assistant
JJGlobal Services
C website: <http://www.jjglobal.services/>
E: ambros.rokop@jjglobal.service
T: 632-1179
F: 632-3550

 **GCC Bid.pdf**
28K

GCC PR0080

5/21/2021

JJ Global International Mail - Fwd: Pre-Bid Conference Minutes



Ambros Mori Rokop Jr. <ambros.rokop@jjglobal.services>

Fwd: Pre-Bid Conference Minutes

1 message

Alleen de Dios <alleen@jjglobal.services>
To: Kit Casin <kit.casin@jjglobal.services>, "Ambros Mori Rokop Jr." <ambros.rokop@jjglobal.services>

----- Forwarded message -----

From: Patricia Palacios <patricia.palacios@guamcc.edu>

Date: Thu, May 20, 2021, 5:52 PM

Subject: Pre-Bid Conference Minutes

To: Claycraft Inc <admin@claycraftinc.com>, <sales@pointhorshade.com>, <sa_tbg@yaho.com>, Alleen de Dios <alleen@jjglobal.services>, <jerome.uson@jjglobal.services>, <coralgbas>
Cc: Guam Community College <materialmanagement@guamcc.edu>, Francisco Palacios <francisco.palacios1@guamcc.edu>, Inocencio SanAgustin <inocencio.sanagustin@guamcc.edu>

To All Prospective Bidders,

Attached is the Pre-Bid Conference Minutes for GCC-FB-21-009, Replacement of Building 900 Metal Awning Structure.

Please acknowledge receipt of this email no later than 5:00 pm, Friday, May 21, 2021.

Thank You,

Patricia U. Palacios

Buyer II

Materials Management Office

materialmanagement@guamcc.edu

Tel: 735-5540/5542



Entity administered by Guam Community College

[Handwritten signature] 5/21/2021

Pre-Bid Conference Minutes.pdf
39K

GUAM COMMUNITY COLLEGE

(Mandatory) Pre-Bid Conference & Site Visit

Date: 10:00 A.M., Wednesday, May 19, 2021

Bid No.: GCC-FB-21-009

Description: Replacement of Building 900 Metal Awning Structure

VENDORS please provide all contact information requested
 PRINT CLEARLY & LEGIBLY

Vendor Name & Address PRINT CLEARLY & LEGIBLY	Representative Name & E-Mail Address	Telephone Number & Fax Number	Date
Vendor Name: <u>Clayarch</u> Vendor Mailing Address: <u>P.O. Box 12511 Tamuning</u>	Full Name: <u>Mrs. Inga Kim</u> E-Mail Address: <u>admin@clayarchinc.com</u>	Telephone Number: <u>488-8290</u> Fax Number:	Date: <u>May 19, 2021</u>
Vendor Name: <u>Margie Annis</u> Vendor Mailing Address: <u>P.O. Box 6128 Tamuning</u>	Full Name: <u>Alice Au-yeung</u> E-Mail Address: <u>sales@getthefunshades.com</u>	Telephone Number: <u>649-3791</u> Fax Number:	Date: <u>May 19, 2021</u>
Vendor Name: <u>TOP BUILDERS LLC</u> Vendor Mailing Address: <u>P.O. Box 20718, BARRIGADA</u>	Full Name: <u>EDWIN AGLAN</u> E-Mail Address: <u>ea-aglan@yahoo.com</u>	Telephone Number: <u>747-6789</u> Fax Number:	Date: <u>May 19, 2021</u>
Vendor Name: <u>JJJ GLOBAL</u> Vendor Mailing Address: <u>215 ROJAS St, Harmon Industrial Park, Tamuning, GU. 96913</u>	Full Name: <u>AARON BURGER</u> E-Mail Address: <u>aileen@jjjglobal.services</u>	Telephone Number: <u>632-1179</u> Fax Number:	Date: <u>MAY 19, 2021</u>
Vendor Name: <u>Guam Community College</u> Vendor Mailing Address: <u>Seane Street Mangilao</u>	Full Name: <u>Francisco Palacios</u> E-Mail Address: <u>francisco.palacios@guamcc.edu</u>	Telephone Number: <u>735-5514</u> Fax Number:	Date: <u>05/19/2021</u>

GUAM COMMUNITY COLLEGE

(Mandatory) Pre-Bid Conference & Site Visit

Date: 10:00 A.M., Wednesday, May 19, 2021

Bid No.: GCC-FB-21-009

Description: Replacement of Building 900 Metal Awning Structure

VENDORS please provide all contact information requested

PRINT CLEARLY & LEGIBLY

Vendor Name & Address PRINT CLEARLY & LEGIBLY	Representative Name & E-Mail Address	Telephone Number & Fax Number	Date
Vendor Name Guam Community College Vendor Mailing Address	Full Name Innocencio J. San Agustín E-Mail Address Innocencio.SANAGUSTIN@guamcc.edu	Telephone Number 735 5501 Fax Number	Date 19 May 21
Vendor Name Guam Community College Vendor Mailing Address P.O. Box 23069 GMF Barrigada, Guam 96921	Full Name Patricia W. Palacios E-Mail Address patricia.palacios@guamcc.edu	Telephone Number 735-5540/42 Fax Number 734-5238	Date 5/19/21
Vendor Name JJ Global Services Vendor Mailing Address po box 217881, GMF Barrigada GU	Full Name USOL Jerome A. E-Mail Address jerome.uson @jglobal services	Telephone Number 480-7963. Fax Number	Date 19 May 2021
Vendor Name JJ Global Services Vendor Mailing Address po box 217881 GMF Barrigada GU	Full Name Bascon, Craig E-Mail Address CRAIGBASCON77@gmail.com	Telephone Number 304-8007 Fax Number	Date 19 May 2021
Vendor Name Guam Community College Vendor Mailing Address P.O. Box 23069 GMF Barrigada, Guam 96921	Full Name Jileen Evangelista E-Mail Address jileen.evangelista@guamcc.edu	Telephone Number 735-5540 Fax Number 734-5238	Date 5/19/21

Procurement Appeal No. OPA-PA-21-013

Procurement Record

Tab 6

Request from
JJ Global

Joleen Evangelista

From: Aileen de Dios <aileen@jjglobal.services>
Sent: Thursday, May 27, 2021 2:18 PM
To: materialsmanagement@guamcc.edu
Subject: GCC-FB-21-009 Replacement of Building 900 Metal Awning Structure

too late
questions due:
5/20/21
responses due
5/25/21

Hafa Adai GCC Procurement Team,

May we formally request for an extension for the bid opening date to be extended 10 more business days?

Thank you and pls advise.

All the best,

Aileen de Dios
General Manager
<http://www.jjglobal.services/>
E: aileen@jjglobal.services
O: 671-632-1179
F: 671-632-3550



E-mail administered by Guam Community College



Response to Question
Late
Patricia Palacios <patricia.palacios@guamcc.edu>
JJ Global

GCC-FB-21-009 Replacement of Building 900 Metal Awning Structure

6 messages

Aileen de Dios <aileen@jjglobal.services>
To: materialsmanagement@guamcc.edu

Thu, May 27, 2021 at 2:17 PM

Hafa Adai GCC Procurement Team,

May we formally request for an extension for the bid opening date to be extended 10 more business days?

Thank you and pls advise.

All the best,

Aileen de Dios
General Manager
<http://www.jjglobal.services/>
E: aileen@jjglobal.services
O: 671-632-1179
F: 671-632-3550



E-mail administered by Guam Community College

Joleen Evangelista <joleen.evangelista@guamcc.edu>
Reply-To: joleen.evangelista@guamcc.edu
To: Rodalyn Gerardo <rodalyn.gerardo@guamcc.edu>
Cc: patricia.palacios@guamcc.edu

Fri, May 28, 2021 at 7:03 PM

Rod,

JJ Global is requesting for an extension from 6/3/2021 to 6/17/21.

3 prospective bidders and no questions asked.

The deadline for questions was 5/20/21 and deadline to respond was 5/25/2021.

Please advise on this. Should I grant the extension? They asked too late.

Thanks,

Joleen

From: Aileen de Dios [mailto:aileen@jjglobal.services]
Sent: Thursday, May 27, 2021 2:18 PM
To: materialsmanagement@guamcc.edu
Subject: GCC-FB-21-009 Replacement of Building 900 Metal Awning Structureq

Hafa Adai GCC Procurement Team,

May we formally request for an extension for the bid opening date to be extended 10 more business days?

Thank you and pls advise.

All the best,

Aileen de Dios

General Manager

<http://www.jjglobal.services/>

E: aileen@jjglobal.services

O: 671-632-1179

F: 671-632-3550

E-mail administered by Guam Community College

[Quoted text hidden]

Rodalyn Gerardo <rodalyn.gerardo@guamcc.edu>
To: Joleen Evangelista <joleen.evangelista@guamcc.edu>
Cc: "patricia.palacios" <patricia.palacios@guamcc.edu>

Sat, May 29, 2021 at 7:51 AM

GCC PR0086

Hi Ms. Joleen,

Given that the questions were due on 5/20/21 and they are only asking now without a reason for the extension, I do not think it would be fair to the other potential bidders. What do you think?

Best Regards,
Rod

[Quoted text hidden]
[Quoted text hidden]

2 attachments

~WRD395.jpg
1K

~WRD395.jpg
1K

Joleen Evangelista <joleen.evangelista@guamcc.edu>
To: Rodalyn Gerardo <rodalyn.gerardo@guamcc.edu>
Cc: "patricia.palacios" <patricia.palacios@guamcc.edu>

Sat, May 29, 2021 at 7:53 AM

Rod,

Yes, I agree.

It's too late. I just hope that we get bids.

Thanks,

Joleen
[Quoted text hidden]

--
Joleen M. Evangelista
Procurement & Inventory Administrator

phone: 671-735-5540
fax: 671-734-5238
email: joleen.evangelista@guamcc.edu
[Quoted text hidden]

Rodalyn Gerardo <rodalyn.gerardo@guamcc.edu>
To: Joleen Evangelista <joleen.evangelista@guamcc.edu>
Cc: "patricia.palacios" <patricia.palacios@guamcc.edu>

Sat, May 29, 2021 at 8:03 AM

I hope so too.

Best Regards,
Rod
[Quoted text hidden]

Joleen Evangelista <joleen.evangelista@guamcc.edu>

Sat, May 29, 2021 at 8:13 AM

GCC PR0087

To: Aileen de Dios <aileen@jglobal.services>, Materials Management Office <materialsmanagement@guamcc.edu>

Ms. de Dios,

Please be advised that your request is too late. Please note that the deadline for questions was 5/20/21 and the deadline to respond was 5/25/21.

Thank you.

Joleen M. Evangelista
Procurement & Inventory Administrator
[Quoted text hidden]

--
Joleen M. Evangelista
Procurement & Inventory Administrator

phone: 671-735-5540
fax: 671-734-5238
email: joleen.evangelista@guamcc.edu

[Quoted text hidden]

Procurement Appeal No. OPA-PA-21-013

Procurement Record

Tab 7

Guam Community College
BID SUBMISSION SIGN IN SHEET
 Date: 10:00 a.m., Thursday, June 3, 2021
 Bid No.: GCC-FB-21-009

Bid Description: Replacement of Building 900 Metal Awning Structure

VENDORS please provide all contact information requested
 PRINT CLEARLY & LEGIBLY

Vendor Name & Address PRINT CLEARLY & LEGIBLY	Representative Name & E-Mail Address	Telephone Number & Fax Number	Date
Vendor Name JT Global Services Vendor Mailing Address P.O. Box 217881 G.M.F. Barrigada, 96921	Full Name <i>Aileen Pe Dios</i> E-Mail Address <i>admin@ijglobal.com</i>	Telephone Number <i>(671) 787-8286</i> Fax Number <i>632-3550</i>	Date <i>06/03/21</i>
Vendor Name CLAYARCH INC. Vendor Mailing Address P.O. Box 12577 Tamuning, GU	Full Name MIN CHUL KOLEY E-Mail Address <i>admin@clayarchinc.com</i>	Telephone Number <i>486-8290</i> Fax Number <i>646-8843</i>	Date <i>6/3/21</i>
Vendor Name Vendor Mailing Address 	Full Name E-Mail Address 	Telephone Number Fax Number 	Date
Vendor Name Vendor Mailing Address 	Full Name E-Mail Address 	Telephone Number Fax Number 	Date
Vendor Name Vendor Mailing Address 	Full Name E-Mail Address 	Telephone Number Fax Number 	Date

GUAM COMMUNITY COLLEGE

BID OPENING SIGN IN SHEET

Date: 10:15 am., Thursday, June 3, 2021

Bid No.: GCC-FB-21-009

Description: Replacement of Building 900 Metal Awning Structure

VENDORS please provide all contact information requested
 PRINT CLEARLY & LEGIBLY

Vendor Name & Address PRINT CLEARLY & LEGIBLY	Representative Name & E-Mail Address	Telephone Number & Fax Number	Date	Received Bid Abstract/Bid Price Form Hard Copy/Email
Vendor Name CLAYARCH, INC. Vendor Mailing Address P.O. BOX 12577 TAMUNINGTA GUAM	Full Name MIN CHUL KONGT E-Mail Address admin@clayarchinc.com	Telephone Number 486-8290 Fax Number 646-8043	Date 6/3/21	(HC) MIN KONGT 6/3/21
Vendor Name STI GLOBAL SERVICES Vendor Mailing Address 8-B BOX 212821, BARRIESTA GUAM COMMUNITY COLLEGE PO BOX 23069 GUMF BARRIESTA, GUAM 96921	Full Name Aileen de Dios E-Mail Address aileen@jglovesol-services	Telephone Number 672-1179 Fax Number	Date 6/3/21	(HC) 6/3/21
Vendor Name PO BOX 23069 GUMF BARRIESTA, GUAM 96921 Vendor Name GCC	Full Name Patricia U. Palacios E-Mail Address patricia.palacios@guamcc.edu Full Name Joleen M. Evangelista E-Mail Address joleen.evangelista@guamcc.edu	Telephone Number 735-5842/40 Fax Number 734-5238 Telephone Number 735-5810 Fax Number 734-5238	Date 6/3/21	
Vendor Name PO. BOX 23069 GUMF BARRIESTA, GUAM 96921 Vendor Name	Full Name Joleen Evangelista E-Mail Address joleen.evangelista@guamcc.edu	Telephone Number 734-5238 Fax Number	Date 6/3/21	
Vendor Mailing Address	Full Name @	Telephone Number Fax Number	Date	

**GUAM COMMUNITY COLLEGE
 BID OPENING SIGN IN SHEET**

Date: 10:15 am., Thursday, June 3, 2021

Bid No.: GCC-FB-21-009

Description: Replacement of Building 900 Metal Awning Structure

**VENDORS please provide all
 contact information requested
 PRINT CLEARLY & LEGIBLY**

	Vendor Name & Address PRINT CLEARLY & LEGIBLY		Representative Name & E-Mail Address		Telephone Number & Fax Number		Date	Received Bid Abstract/Bid Price Form Hard Copy/Email
	Vendor Name	Vendor Mailing Address	Full Name	E-Mail Address	Telephone Number	Fax Number		
6	Vendor Name		Full Name		Telephone Number		Date	
	Vendor Mailing Address		E-Mail Address	@	Fax Number			
7	Vendor Name		Full Name		Telephone Number		Date	
	Vendor Mailing Address		E-Mail Address	@	Fax Number			
8	Vendor Name		Full Name		Telephone Number		Date	
	Vendor Mailing Address		E-Mail Address	@	Fax Number			
9	Vendor Name		Full Name		Telephone Number		Date	
	Vendor Mailing Address		E-Mail Address	@	Fax Number			
10	Vendor Name		Full Name		Telephone Number		Date	
	Vendor Mailing Address		E-Mail Address	@	Fax Number			

Guem Community College
 Bid Abstract/Bid Price Form
 Bid No. GCC-FB-21-009

Replacement of Building 900 Metal Awning Structure
 Bid Opening Date: 10:15 am, Thursday, June 3, 2021

Item	Description of Work	Vendor 1: JJ Global Services		Vendor 2: Clay Arch Inc.		Vendor 3:		Total		
		Cost for Supplies, Materials, etc.	Cost for Labor	Total	Cost for Supplies, Materials, etc.	Cost for Labor	Total		Cost for Supplies, Materials, etc.	Cost for Labor
a	Removal and disposal of the existing awning. (i.e. Corrugated roof sheet panels, purlins, rafters, etc.)		10,355.39	10,355.39		9,640.00		9,640.00		
b	Removal and disposal of the existing metal columns and beams		4,002.08	4,002.08		10,250.00		10,250.00		
c	Installation of new metal columns and beams (Option 1 for Black Iron and Option 2 for Galvanized)	Option 1: 70,087.18 Option 2: 53,760.79	Option 1: 18,397.81 Option 2: 18,397.81	Option 1 - 88,485.00 Option 2 - 72,158.60	Option 1 - 34,240.00 Option 2 - 43,340.00	58,500.00 (7,900.00)		58,500.00 (7,900.00)		
d	Installation of cable bracing at three (3) specific locations	3,751.95	1,500.78	5,252.74	6,560.00	4,100.00		10,660.00 (0,660.00)		
e	Installation of new Purlins, S-layer and Z-6" over lap including all component elements	8,754.56	3,501.82	12,256.38	13,580.00	11,890.00		27,470.00 (7,470.00)		
f	Installation of new rafter system including all component elements:	16,456.27	1,645.63	18,101.89	6,560.00	8,610.00		15,170.00 (5,170.00)		
g	Installation of 22 Gauge thickness corrugated roof sheet panels to include roof sealant for fastener and joint protection and leak prevention.	22,511.72	9,004.69	31,516.41	21,390.00	16,200.00		37,590.00 (3,590.00)		
h	Application of Oil based primer and two (2) coats final paint on corrugated roof sheet panels (top and bottom)	5,402.81	2,161.13	7,563.94	2,050.00	2,050.00		4,100.00 (4,100.00)		
i	Removal and reinstatement of additional tools, equipment, infrastructure, etc... into the new awning structure.		2,084.42	2,084.42	2,460.00	7,170.00		9,630.00 (9,630.00)		
Total Bid Price		Option 1: 119,590.34 Option 2: 103,263.24	Option 1: 34,687.84 Option 2: 34,687.84	Option 1: 154,278.18 Option 2: 137,951.08	Option 1: 88,485.00 Option 2: 72,158.60	Option 1: 154,278.18 Option 2: 137,951.08	Option 1: 158,000.00 Option 2: 142,000.00	Option 1: 158,000.00 Option 2: 142,000.00	Option 1: 158,000.00 Option 2: 142,000.00	Option 1: 158,000.00 Option 2: 142,000.00

Opened By: Spencer W. Samsel Date: 6/3/2021 Witnessed By: [Signature] Date: 6/3/21

Guam Community College
 Bid No.: GCC-FB-21-009
 Bid Description: Replacement of Existing 900 Metal Awning Structure
 10:15 am, Thursday, June 3, 2021

Vendor Name	Bid Total Amount	Bid Guarantee	Certificate of Authority	Power of Attorney	Affidavit of Disclosing Ownership and Commissions	Non-Collusion Affidavit	Affidavit to No Gratuities or Kickbacks	Affidavit to Ethical Standards	Affidavit to Contingent Fees	Declaration Re Compliance w/ U.S. DOL Wage Determination	Brochure/Descriptive Literature/Technical Specifications	Project Narrative	CPM Chart	Conceptual Design	Contractor's or Business License	Pre Bid Minutes/Amendments Acknowledged	REMARKS
IT Global Services	Option 1 - \$179,590.24 Option 2 - \$168,218.84	(Bid Guarantee) HOK Nissay Banc Ins. Co. 15% of bid amt 6/1/21 - through 4 mos.	✓	✓	✓	✓	✓	✓	✓	✓ w/ wage listing	✓	✓	✓	✓	CL 4/26/21	✓	1 original 2 copies
ClayArch Inc.	Option 1 - \$183,000.00 Option 2 - \$192,000.00	Bid Bond 15% Leyson Ins. Co. 15% of bid amt 5/27/21 through 4 mos.	✓	✓	✓	✓	✓	✓	✓	✓ w/ wage listing	✓	✓	✓	✓	CL 4/26/21	✓	1 original 2 copies Warranty Certificate cost of 0.15%

Opened By: Juan M. Gonzalez Date: 6/3/2021 Witnessed By: [Signature] Date: 6/3/21

Procurement Appeal No. OPA-PA-21-013

Procurement Record
Tab 8

GUAM COMMUNITY COLLEGE
BID INVITATION

Mary A.Y. Okada, Ed.D.
GCC PRESIDENT

GUAM COMMUNITY COLLEGE
P.O. BOX 23069 GMF, GUAM 96921
1 SESAME STR. MANGILAO, GUAM 96913

DATE ISSUED: May 13, 2021 BID INVITATION NO.: GCC-FB-21-009

INSTRUCTION: This BID shall be submitted in original, plus Two (2) copies, in a sealed envelope and delivered to the specified location below on or before (Time) 10:00 A.M., (Date) Thursday, June 03, 2021. The Bid shall be Publicly opened at 10:15 A.M. Bids submitted after the time and date specified above shall be rejected. See attached Solicitation Instructions and Conditions for details.

BID FOR:
SPECIFICATIONS:
BID SUBMISSION LOCATION:

Replacement of Building 900 Metal Awning Structure
See Attached Scope of Work
GUAM COMMUNITY COLLEGE
Materials Management Office
Room 2105 1st fl. Administration Bldg. 2000

Mandatory Pre-Bid Conference & Site Visit

10:00 am., Wednesday, May 19, 2021
GCC Technology Center Building 1000, Room 1107

BID OPENING LOCATION:
REQUIRED DELIVERY DATE:

GCC Technology Center, Building 1000, Room 1107
90 Calendar Days upon Receipt of the Purchase Order/Contract

SUBMISSION DEADLINE FOR QUESTIONS:
DEADLINE FOR GCC RESPONSES:

5:00 P.M., Thursday, May 20, 2021
5:00 P.M., Tuesday, May 25, 2021

ALL INQUIRIES REGARDING THIS BID MUST BE ADDRESSED TO: Procurement & Inventory Administrator, Materials Management Office

MATERIALS MANAGEMENT CONTACT INFORMATION: TELEPHONE: 735-5542/5540; FACSIMILE: 734-5238;
EMAIL: materialsmanagement@guamcc.edu; WEBSITE: www.guamcc.edu

NOTE TO BIDDERS:

This bid is subject to the attached General Terms and Conditions of the Invitation for Bids. The undersigned offers and agrees to furnish within the time specified, the articles and services at the price stated opposite otherwise specified by the bidder. The undersigned further agrees this bid will remain firm and irrevocable if accepted within ___ calendar days (60 calendar days unless a different period is inserted), from the date of the opening, to furnish any or all of the items which prices are quoted.

INDICATE WHETHER: INDIVIDUAL PARTNERSHIP CORPORATION

INCORPORATED IN:

NAME AND ADDRESS OF BIDDER:

JJ Global Services
PO Box 217881
Barrigada GU, 96921

LUC B. DISTANTE - CEO
SIGNATURE AND TITLE OF PERSON
AUTHORIZED TO SIGN THIS BID:

AWARD:	CONTRACT NO.:	AMOUNT:	DATE:
ACCEPTED AS TO ITEMS NUMBERED:			

CONTRACTING OFFICER

GCC PRESIDENT

NAME AND ADDRESS OF CONTRACTOR:

SIGNATURE AND TITLE OF PERSON AUTHORIZED
TO SIGN THIS CONTRACT



Guam Community College
 PO Box 23069
 Barrigada, Guam 96921

Accountability • Impartiality • Competence • Openness • Value

INVITATION FOR BID (IFB) NO.: GCC-FB-21-009

DESCRIPTION: Replacement of Building 900 Metal Awning Structure

SPECIAL REMINDER TO PROSPECTIVE BIDDERS

Bidders are reminded to read the Sealed Bid Solicitation and Instructions, and General Terms and Conditions attached to the IFB to ascertain that all of the following requirements checked below are submitted in the bid envelope, original and two (2) copies, at the date and time for bid opening.

- BID GUARANTEE (15% OF BID AMOUNT) – May be in the form of;**
 - a. **Cashier's Check or Certified Check**
 - b. **Letter of Credit (must not expire no earlier than ninety (90) days from the date of submittal); or**
 - c. **Surety Bond – Valid only if accompanied by:**
 - 1. **Current Certificate of Authority issued by the Insurance Commissioner;**
 - 2. **Power of Attorney issued by the Surety to the Resident General Agent;**
 - 3. **Power of Attorney issued by two (2) major officers of the Surety to whoever is signing on their behalf.**
- BROCHURES/DESCRIPTIVE LITERATURE/Technical Specifications: To make it easier to evaluate, please tab and reference each item number (18a – 18e) and highlight each specification requirement and attach the descriptive literature/product brochure for each respective item number.**
- Project Narrative: Describing how the qualified contractor will address this project's Scope of Work**
- CPM Chart (Critical Path Method) to illustrate the Qualified Contractor's timeline to complete the project, within (Ninety) 90 consecutive calendar days upon receipt of a purchase order & inclusive of the building permit, process & material lead time.**
- Conceptual Design: Illustrating the size and design of the awning.**
- AFFIDAVIT OF DISCLOSING OWNERSHIP AND COMMISSIONS – Must comply with the following requirements:**
 - a. **A bidder intends to participate in a bid opening on October 15 and submits his/her bid on September 12, the affidavit dated September 10 is acceptable**
 - b. **If the affidavit is a copy, indicate the Bid No. and where it is filed**
- NON-COLLUSION AFFIDAVIT, AFFIDAVIT re: GRATUITIES AND KICKBACKS, AFFIDAVIT re: ETHICAL STANDARDS AND AFFIDAVIT re: CONTINGENT FEES (must be notarized)**
- Declaration Re Compliance with U.S. DOL Wage Determination: Please see instructions in U.S. DOL Form**
- Acknowledgement receipts of pre-bid minutes and or addendums upon issuance from Materials Management Office**
- Copy of current and valid Guam Contractors license (upon Issuance of Award)**
- Non-Refundable fee of \$25.00 must be paid on or before the Mandatory Pre-Bid Conference & Site Visit date.**
- Failure to comply with the requirements in the special reminder will be a basis for disqualification and rejection of the bid. This reminder must be signed and returned in the bid envelope together with the bid. Failure to comply with the above requirements will mean a disqualification and rejection of the bid. On this 18th day of May 2021, Aileen de Dios, _____ acknowledge receipt of this special reminder to prospective bidders with the above referenced IFB.**

Aileen de Dios
 Bidder Representative's Signature

**GUAM COMMUNITY COLLEGE
SEALED BID SOLICITATION
INSTRUCTIONS**

This solicitation is issued subject to all the provisions of Guam Procurement Laws in 5 G.C.A. chapter 5, and 2 G.A.R., div4 (both are available online at: <http://www.guamcourts.org/CompilerofLaws/index.html>).

1. BID FORMS:

Each Bidder shall be provided with one (1) set of Solicitation forms. Additional copies may be provided by request.

2. PREPARATION OF BIDS:

(a) Bidders are required to examine all drawings, specifications, schedules, and all other accompany instructions and documents.

(b) Each bidder shall furnish the information required by the Solicitation. The bidder shall sign the Solicitation and print or type his/her name on the Schedule. Erasures or other changes must be initialed by the person signing the bid. Bids signed by an agent are to be accompanied by evidence of his/her authority unless such evidence has been previously furnished to the issuing office.

(c) Unit price for each unit offered shall be shown and such price shall include packing unless otherwise specified. A total shall be entered in the amount column of the Schedule for each item offered. In case of discrepancies between a unit price and the extended price, the unit price will be presumed to be correct.

(d) Bids for supplies or services other than those specified will not be considered.

(e) Bids must state a definite time for delivery of supplies or performance of services.

(f) Time, if stated as a number of days, means calendar days and will include Saturdays, Sundays, and holidays. Time stated ending on a Saturday, Sunday or Government of Guam legal holiday will end at the close of the next business day.

3. EXPLANATION TO BIDDERS:

Any explanation desired by a bidder regarding the meaning or interpretation of the Solicitation, drawings, specifications, etc., must be submitted in writing and with sufficient time allowed for a written reply to reach all bidders before submission on their bids. Oral explanation or instructions given before the award of the contract will not be binding. Any information given to a prospective bidder concerning a Solicitation will be furnished to all prospective bidders in writing as an amendment to the Solicitation if such information is necessary for bidders in submitting bids on the Solicitation or if the lack of such information would be prejudicial to uniformed bidders.

4. ACKNOWLEDGEMENT OF AMENDMENTS TO SOLICITATIONS:

Receipt of an amendment to a Solicitation by a bidder must be acknowledged by signing an acknowledgement of receipt of the amendment. Such acknowledgement must be received prior to the hour and date specified for receipt of bids.

9. GOVERNMENT FURNISHED PROPERTY:

No material, labor or facilities will be furnished by the College unless otherwise provided for in the Solicitation.

10. SELLER'S INVOICES:

Invoices shall be prepared and submitted in quadruplicate (one copy shall be marked "original") unless otherwise specified. Invoices shall be "certified true and correct" and shall contain the Contract and Order Number, item numbers, description of supplies or services, sizes, quantities, unit prices, and extended total. Bill of lading number and weight of shipment will be shown for shipments made on Government bills of lading.

11. RECEIPT, OPENING AND RECORDING OF BIDS:

Bids and modifications shall be publicly opened in the presence of one or more witnesses, at the time, date, and place designated in the Invitation for Bids. The name of each bidder, the bid price, and such other information as is deemed appropriate by the Procurement Officer, shall be read aloud and recorded, or otherwise made available. The names and addresses of required witnesses shall be recorded at the opening. The opened bids shall be available for public inspection except to the extent the bidder designates trade secrets or other proprietary data to be confidential as set forth in accordance with Guam laws. Each page of confidential or proprietary information in the bid shall be labeled "confidential" or "proprietary". Material so designated shall accompany the bid and shall be readily separable from the bid in order to facilitate public inspection of the non-confidential portion of the bid. All non-confidential and non-proprietary information shall be publicly available at the time of bid opening.

12. CONFIDENTIAL DATA:

The Procurement Officer shall examine the bids to determine the validity of any request for non-disclosure of trade secrets and other confidential or proprietary data identified in writing. If the parties do not agree as to the disclosure of the data, either party may file a protest according to Guam Procurement Law. The bids shall be opened to public inspection subject to any continuing prohibition on the disclosure of confidential data.

**GENERAL TERMS AND CONDITIONS
SEALED BID SOLICITATION AND AWARD
(Only items marked "X" are applicable to this bid).**

(X)1. AUTHORITY:

This solicitation is issued subject to all the provisions of Guam Procurement Laws in 5 GCA Chapter 5, and 2 GAR, Div. 4 (both are available online at <http://www.guamcourts.org/Compileroflaws/index.html>). Guam Procurement Law requires that all parties involved act in good faith.

(X)2. GENERAL INTENTION:

It is the declared and acknowledged intention and meaning of these General Terms and Conditions for the bidder to provide Guam Community College with specified services or with materials, supplies or equipment completely assembled and ready for use.

(X)3. TAXES:

Bidders are cautioned that they are subject to Guam Income Taxes as well as other taxes on Guam Transactions. Specified information on taxes may be obtained from the Director of Revenue and Taxation.

(X)4. LICENSING:

Bidders are cautioned that the College will not consider for award any offer submitted by a bidder who has not complied with the Guam Licensing Law. Specific information on licenses may be obtained from the Director of Revenue and Taxation.

()5. LOCAL PROCUREMENT PREFERENCE:

All procurement of supplies and services will be made from among businesses licensed to do business in Guam in accordance with Guam Procurement Law.

(X)6. COMPLIANCE WITH SPECIFICATIONS AND OTHER SOLICITATION REQUIREMENTS: Bidders shall comply with all specifications and other requirements of the Solicitation.

(X)7. "ALL OR NONE" BIDS:

Unless otherwise allowed under this solicitation, "all or none" bids shall be deemed to be non-responsive. If the bid is so limited, the College shall not reject part of such proposal and award on the remainder. The whole bid must be rejected.

(X)8. INDEPENDENT PRICE DETERMINATION:

The bidder, upon signing the Invitation to Bid, certifies that the prices in the bid were derived at without collusion, and acknowledge that collusion and anticompetitive practices are prohibited by law. Violations will be subject to Guam Procurement laws. Other existing civil, criminal or administrative remedies are not impaired and may be in addition to the remedies in Guam Procurement laws.

(X)9. BIDDER'S PRICES:

The College will consider not more than two (2) (Basic and Alternate) item prices and the bidder shall explain fully each price if supplies, materials, equipment, and/or specified

services offered comply with specifications and the product's origin. Where basic or alternate bid meets the minimum required specification, cost and other factors will be considered. Failure to explain this requirement will result in rejection of the bid.

(X)10. BID ENVELOPE:

Envelope shall be sealed and marked with the bidders' name, bid number, time, date and place of Bid Submission.

(X)11. AFFIDAVIT DISCLOSING OWNERSHIP AND COMMISSIONS (AG Form 002):

Each person submitting a bid for any portion of the work covered by the bid documents shall execute an affidavit on the form provided when the person(s) who have held more than ten percent (10%) of the company's shares during the past twelve (12) months. Such affidavit shall be attached to the bid. Failure to submit with the bid shall be cause for rejection of bid.

(X)12. NON-COLLUSION AFFIDAVIT (AG Form 003):

Each person submitting a bid for any portion of the work covered by the bid documents shall execute an affidavit on the form provided, certifying to the effect that he/she has not colluded with any other person, firm or corporation in regards to any bid submitted. Such affidavit shall be attached to the bid. Failure to submit with the bid shall be cause for rejection of bid.

(X)13. AFFIDAVIT RE GRATUITIES, KICKBACKS AND FAVORS (AG Form 004):

The bidder, offeror or contractor agrees that it will not violate the prohibition against gratuities, kickbacks, and favors set forth (Gratuities and Kickbacks) in 5 GCA, Chapter 5, Article 11. Such affidavit shall be attached to the bid. Failure to submit with the bid shall be cause for rejection of bid.

(X)14. AFFIDAVIT RE ETHICAL STANDARDS (AG Form 005):

The bidder, offeror, or contractor represents that it has not knowingly influenced and promises that it will not knowingly influence a government employee to breach any of the ethical standards set forth in 5 GCA Chapter 5 Article 11 (Ethics in Public Contracting) of the Guam Procurement Act and in Chapter 11 of the Guam Procurement Regulations. Such affidavit shall be attached to the bid. Failure to submit with the bid shall be cause for rejection of bid.

(X)15. DECLARATION RE COMPLIANCE WITH U.S. DEPARTMENT OF LABOR WAGE DETERMINATION (AG Form 006):

In compliance to wage and benefits pursuant to 5GCA §5211(b) and 5 GCA §5801 and §5802, as may be applicable, each bidder certifies that any of its employees whose purpose, in whole or part, is the direct delivery of service contracted by the Government shall be paid in accordance with the Wage Determination for Guam and the Northern Marianas Islands issued and promulgated by the U.S. Department of Labor for such Labor as is employed in the direct delivery of contract deliverables to the Government, including health and other similar benefits. Failure to submit with the bid shall be cause for rejection of bid.

(X)16. AFFIDAVIT REGARDING CONTINGENT FEES (AG Form 007):

The bidder, offeror, or contractor represents that it has not retained a person to solicit or secure a Government contract upon an agreement or understanding for a commission, percentage, brokerage, or contingent fee, except for retention of bona fide employees or bona fide established commercial selling agencies for the purpose of securing business. Such affidavit shall be attached to the bid. Failure to submit with the bid shall be cause for rejection of bid.

(X)17. BID BOND REQUIREMENT:

Bidder is required to submit a Bid Guarantee Bond or standby irrevocable Letter of Credit or Certified Check or Cashier's Check in the same bid envelope to be held by the College pending award. The Bid Guarantee Bond, Letter of Credit, Certified Check or Cashier's Check must be issued by any local surety or banking institution licensed to do business on Guam and made payable to the Guam Community College, in the amount of fifteen percent (15%) of the highest total bid offer. Bid guarantee will be a Bid Bond on Government Standard Form BB- (copy enclosed). Personal Checks will not be accepted as Bid Guarantee. If a successful Bidder (contractor) withdraws from the Bid or fails to enter into contract within the prescribed time, such Bond will be forfeited to the Guam Community College. Bid will be disqualified if not accompanied by Bid Bond, Letter of Credit, Certified Check or Cashier's Check. Bidder must include in his/her bid, valid copies of a Power of Attorney from the Surety and a Certificate of Authority from the Government to show proof that the surety company named on the bond instrument is authorized by the Government of Guam and qualified to do business on Guam. For detailed information on bonding matters, contact the Department of Revenue and Taxation. Failure to submit a valid Power of Attorney and Certificate of Authority on the surety is cause for rejection of bid.

(X)18. PERFORMANCE BOND REQUIREMENT:

The Bidder may be required to furnish a Performance Bond on Government Standard Form BB- or standby irrevocable Letter of Credit or Certified Check or Cashier's Check payable to the Guam Community College issued by any of the local Banks or Bonding Institution in the amount equal to one-hundred percent (100%) of the contract prices as security for the faithful performance and proper fulfillment of the contract. In the event that any of the provisions of this contract are violated by the contractor, the Chief Procurement Officer shall serve written notice upon both the contractor and the Surety of its intention to terminate the contract. Unless satisfactory arrangement or correction is made within the ten (10) days of such notice the contract shall cease and terminate upon the expiration of ten (10) days. In the event of any such termination, the Chief Procurement Officer shall immediately serve notice thereof upon the Surety. The Surety shall have the right to take over and perform the contract, provided, however, that if the Surety does not commence performance thereof within ten (10) days from the date of the mailing of notice of termination, the College may take over and prosecute the same to complete the contract or force account for and at the expense of the contractor, and the contractor and his Surety shall be liable to the College for any excess cost occasioned the Government.

(X)19. PERFORMANCE GUARANTEE:

Bidders who are awarded a contract under this solicitation, guarantee that goods will be delivered or required services performed within the time specified. Failure to perform the contract in a satisfactory manner may be cause for suspension or debarment from doing business with the Government and to enforce Section 12 of these General Terms and Conditions. In addition, the College will hold the Vendor liable and will enforce the requirements as set forth in Section 41 of these General Terms and Conditions.

(X)20. SURETY BONDS:

Bid and Performance Bonds coverage must be signed or countersigned in Guam by the surety's resident general agent. The Surety must be Insurance Company, authorized by the Government of Guam and qualified to do business in Guam. Bids will be disqualified if the Surety Company does not have a valid Certificate of Authority from the Government of Guam to conduct business in Guam.

(X)21. COMPETENCY OF BIDDERS:

Bids will be considered only from such bidders who, in the opinion of the Government, can show evidence of their ability, experience, equipment, and facilities to render satisfactory service.

(X)22. DETERMINATION OF RESPONSIBILITY OF BIDDERS:

The Chief Procurement Officer reserves the right to secure from bidders information to determine whether or not they are responsible and to inspect plant site, place of business; and supplies and services as necessary to determine their responsiveness.

(X)23. STANDARD FOR DETERMINATION OF LOWEST RESPONSIBLE BIDDER:

In determining the lowest responsible offer, the Chief Procurement Officer shall be guided by the following:

- a) Price of Items offered.
- b) The ability, capacity, and skill of the Bidder to perform.
- c) Whether the Bidder can perform promptly or within the specified time.
- d) The quality of performance of the Bidder with regards to award previously made to him.
- e) The previous and existing compliance by the Bidder with laws and regulations relative to procurement.
- f) The sufficiency of the financial resources and ability of the Bidder to perform.
- g) The ability of the bidder to provide future maintenance and services for the subject award.
- h) The compliance with all of the conditions to the Solicitation

(X)24. TIE BIDS:

If the bids are for the same unit price or total amount in whole or in part, the Chief Procurement Officer has the authority to award the bid to any one of the bidders by drawing lots in public, or to reject all such bids.

(X)25. BRAND NAMES:

Any reference in the Solicitation to manufacturer's Brand Names and number is due to lack of a satisfactory specification of commodity description. Such reference is intended to be descriptive, but not restrictive and for the sole purpose of indicating to prospective bidders a

description of the article or services that will be satisfactory. Bids on comparable items will be considered provided the bidder clearly states in his bid the exact articles he is offering and how it differs from the original specification.

(X)26. DESCRIPTIVE LITERATURE:

Descriptive literature(s) as specified in this solicitation must be furnished as a part of the bid and must be received at the date and time set for opening Bids. The literature furnished must clearly identify the item(s) in the Bid. The descriptive literature is required to establish, for the purpose of evaluation and award, details of the product(s) the bidder proposes to furnish including design, materials, components, performance characteristics, method of manufacture, construction, assembly or other characteristics which are considered appropriate. Rejection of the Bid will be required if the descriptive literature(s) do not show that the product(s) offered conform(s) to the specifications and other requirements of this solicitation. Failure to furnish the descriptive literature(s) by the time specified in Solicitation will require rejection of the Bid.

()27. SAMPLES:

Sample(s) of item(s) as specified in this solicitation must be furnished as a part of the bid and must be received at the date and time set for opening Bids. The sample(s) should represent exactly what the Bidder proposes to furnish and will be used to determine if the item(s) offered complies with the specifications. Rejection of the Bid will be required if the sample(s) do not show that the product(s) offered conform(s) to the specifications and other requirements of this solicitation. Failure to furnish the sample(s) by the time specified in the Solicitation will require rejection of the Bid.

()28. LABORATORY TEST:

Successful bidder is required to accompany delivery of his goods with a Laboratory Test Report indicating that the product he is furnishing the College meets the specifications. This report is on the bidder's account and must be from a certified Testing Association.

(X)29. AWARD, CANCELLATION & REJECTION:

Award shall be made to the lowest responsible and responsive bidder, whose bid is determined to be the most advantageous to the Government, taking into consideration the evaluation factors set forth in this solicitation. No other factors or criteria shall be used in the evaluation. Award issued to the lowest responsible bidder within the specified time for acceptance as indicated in the solicitation, results in a binding contract without further action by either party. The right is reserved as the interest of the Government and may require to waive any minor irregularity in the bid received pursuant to 2 GAR, Div. 4 §3109(m)(4)B).

An Invitation for Bid, Request for Proposal, or other solicitation may be cancelled, or any or all bids proposals may be rejected in whole or in part as may be specified in the solicitation, when it is in the best interest of the Territory in accordance with regulations promulgated by the Policy Office, pursuant to 5 GCA § 5225. The reasons therefore shall be made part of the contract file. Each solicitation issued by the territory shall state that the solicitation may be cancelled pursuant to 2 GAR Div. 4 §3115(c).

Each solicitation issued by the territory shall provide that any bid or proposal may be rejected in whole or in part when in the best interest of the Territory as provided in the regulations pursuant to 2 GAR Div. 4, §3115(e)(2).

(X)30. The College reserves the right to increase or decrease the quantity of the items for award and make additional awards for the same type items and the vendor agrees to such modifications and additional awards based on the bid prices for a period of thirty (30) days after original award. No award shall be made under this solicitation which shall require advance payment or irrevocable letter of credit from the Government. Pursuant to 2 GAR, Div. 4 §1103.

(X)31. **MARKING:**

Each outside container shall be marked with the Purchase Order number, item number, brief item description and quantity. Letter marking shall not be less than 3/4" in height.

(X)32. **SCHEDULE FOR DELIVERY:**

Successful bidder shall notify the Guam Community College, Telephone No. 735-5542/5540, at least twenty-four (24) hours before delivery of any item under this solicitation.

(X)33. **BILL OF SALE:**

Successful bidder shall render Bills of Sale for each item delivered under this contract. Failure to comply with this requirement will result in rejection of delivery. The Bills of Sale must accompany the items delivered but will not be considered as an invoice for payment. Supplier shall bill the College with an original invoice.

(X)34. **MANUFACTURER'S CERTIFICATE:**

Successful bidder is required, upon delivery of any item under this contract, to furnish a certificate from the manufacturer indicating that the goods meet the specifications. Failure to comply with this request will result in rejection of delivery.

(X)35. **INSPECTION:**

All supplies, materials, equipment, or services delivered under this contract shall be subject to the inspection and/or test conducted by the College at destination. If in any case the supplies, materials, equipment, or services are found to be defective in material, workmanship, performance, or otherwise do not conform with the specifications, the College shall have the right to reject the item(s) or require that they be corrected. The number of days required for correction will be determined by the College.

()36. **MOTOR VEHICLE SAFETY REQUIREMENTS:**

Guam Community College will only consider Bids on motor vehicles which comply with requirements of all Guam and Federal Laws.

() 37. SAFETY INSPECTION:

All motor vehicles delivered under this contract must pass the Government of Guam Vehicle Inspection before delivery at destination.

(X)38. GUARANTEE:

a) **Guarantee of Vehicle Type of Equipment:** The successful bidder shall guarantee vehicular type equipment offered against defective parts, workmanship, and performance, for a period of not less than one (1) year after date of receipt of equipment. Bidder shall also provide service to the equipment for at least one (1) year. Service to be provided shall include, but will not be limited to tune-ups (change of spark plugs, contact points and condensers) and lubrication (change of engine and transmission oil). All parts and labor shall be at the expense of the bidder. All parts found defective and not caused by misuse, negligence or accident within the guarantee period shall be repaired, replaced, or adjusted within six (6) working days after notice from the College and without cost to the College. Vehicular type equipment as used in this context shall include equipment used for transportation as differentiated from tractors, backhoe, etc. b) **Guarantee of Other Type Equipment:** The successful bidder shall guarantee all other types of equipment offered, except those mentioned in 31a, above, against defective parts, workmanship, and performance for the life of the contract. Bidder shall also provide service to the equipment for the life of the contract. All parts found defective within that period shall be repaired or replaced by the Contractor without cost to the College. Repairs, adjustments or replacement of defective parts shall be completed by the successful bidder as set forth in the bid. c) **Compliance with this Section is a condition of this Bid.**

(X)39. AMENDMENTS TO INVITATION FOR BIDS:

No changes to the IFB can be made unless a change is made by written amendment. Pursuant to 2 GAR, Div. 4. §3109(i), Amendments to Invitation For Bids shall be identified as such and shall require that the bidder acknowledge receipt of all amendments issued. The amendments shall reference the portions of the Invitation for Bids it amends.

(X)40. RIGHT TO AUDIT RECORDS:

The territory may, at reasonable times and places, audit the books and records of any person who has submitted cost or pricing data pursuant to 5 GCA §5232 (Cost or Pricing Data) of the Guam Procurement Act, to the extent that such books and records relate to such cost or pricing data. Any person who receives a contract, change order, or contract modification for which cost or pricing data is required, shall maintain such books and records that relate to such cost or pricing data for three (3) years from the date of final payment under the contract, unless a shorter period is otherwise authorized in writing pursuant to 2 GAR §3124(a).

(X)41. EQUAL EMPLOYMENT OPPORTUNITY:

Contractors shall not discriminate against any employee or applicant for employment because of race, color, religion, sex, or national origin. The contractor will take affirmative action to ensure that employees are treated equally during employment without regards to their race, color, religion, sex, or national origin.

(X)42. COMPLIANCE WITH LAWS:

Bidders awarded a contract under this Solicitation shall comply with the applicable standards, provisions, and stipulations of all pertinent Federal and/or local laws, rules, and regulations relative to the performance of this contract and the furnishing of goods.

(X)43. CHANGE ORDER:

Any change order issued relative to awards made under this solicitation will be subject to and in accordance with the provisions of the Guam Procurement Laws.

(X)44. STOP WORK ORDER:

Any stop work issued relative to awards made under this solicitation will be subject to and in accordance with 2 GAR Div 4, §6101 (4)(e) of the Guam Procurement Laws.

(X)45. TERMINATION FOR CONVENIENCE:

Any termination order for the convenience of the College issued relative to awards made under this solicitation will be subject to and in accordance with the Guam Procurement Laws.

(X)46. TIME FOR COMPLETION:

It is hereby understood and mutually agreed by and between the contractor and the College that the time for delivery to final destination or the timely performance of certain services is an essential condition of this contract. If the contractor refuses or fails to perform any of the provisions of this contract within the time specified in the Purchase Order (from the date Purchase Order is acknowledged by vendor), then the contractor is in default. Defaults will be treated subject to and in accordance with the provisions of the Guam Procurement Laws.

(X)47. JUSTIFICATION OF DELAY:

Bidders who are awarded contracts under this Solicitation, guarantee that the goods will be delivered to their destination or required services rendered within the time specified. If the bidder is not able to meet the specified delivery date, he is required to notify the Chief Procurement Officer of such delay. Notification shall be in writing and shall be received by the Chief Procurement Officer at least twenty-four (24) hours before this specified delivery date. Notification of delay shall include an explanation of the causes and reasons for the delay including statement(s) from supplier or shipping company causing the delay. The College reserves the right to reject delay justification if, in the opinion of the Chief Procurement Officer, such justification is not adequate.

(X) 48. LIQUIDATED DAMAGES:

When the Contractor is given notice of delay or non-performance as specified in Paragraph 1 (Default) of the Termination for Default Clause on this contract and fails to cure in the time specified, the contractor shall be liable for damages for delay in the amount of one-fourth of one percent (1%) of outstanding order per calendar day from date set for cure until either the territory reasonably obtains similar supplies or services if the contractor is terminated for default, or until the contractor provided the supplies or services if the contractor's delay or non-

performance is excused under Paragraph 40 (Excuse for Non-Performance or Delayed Performance) of the Termination for Default of this contract, liquidated damages shall not be due the territory. The contractor remains liable for damages caused other than by delay.

(X)49. PHYSICAL LIABILITY:

If it becomes necessary for the Vendor, either as principal, agent or employee, to enter upon the premises or property of the Guam Community College in order to construct, erect, inspect, make delivery or remove property hereunder, the Vendor hereby covenants and agrees to take, use, provide and make all proper, necessary and sufficient precautions, safeguards and protection against the occurrence of any accidents, injuries or damages to any person or property during the progress of the work herein covered, and to be responsible for, and incurred for or by reason of the violations of any territorial ordinance, regulations, or the laws of Guam or the United States, while the work is in progress. Contractor will carry insurance to indemnify the Guam Community College against any claim for loss, damage or injury to property or persons arising out of the performance of the Contractor or his employees and agents of the services covered by the Contract and the use/misuse or failure of any equipment used by the contractor or his employees or agents, and shall provide certificates of such insurance to the Guam Community College when required.

() 50. HIRING OF APPRENTICES THROUGH THE APPRENTICE TRAINING PROGRAM:

It is the policy of the Government of Guam that all construction projects funded in whole or in part by local or federal funds shall require the contractor to employ at least: One (1) apprentice for every Ten (10) workers for the duration of each project, and not less than one (1) apprentice per project. This requirement may only be waived if the contractor certifies that no apprentice is available. It applies only to projects over Five Hundred Thousand Dollars (\$500,000).

() 51. BUY AMERICAN PRODUCT:

Buy American requirement – all iron, steel, & manufactured goods used in project are produced in the United States.

(X)52. SERVICE-DISABLED VETERAN OWNED BUSINESS PREFERENCE:

Bidding is subject to the policy in favor of Service-Disabled Veteran Owned Business as defined in 5 GCA §5011 and §5012.

(X)53. RESTRICTIONS ON SEX OFFENDERS:

Upon Notice of Intent to Award, the selected Bidder will be required to submit a list of the names of individuals assigned to this project. This is to ensure that the workers assigned to this project are not on the Sex Offender Registry as required by P.L. 28-98.

The Contractor must warrant that no person shall provide services on his behalf in relation to this contract who has been convicted of sex offense under the provisions of **Chapter 25 of Title 9 GCA** or an offense as defined in **Article 2 of Chapter 28, Title 9 GCA** or an offense in another jurisdiction with, at a minimum, the same elements as such offenses, or who is listed in the Sex Offender Registry. Any such person who is discovered to have been so convicted shall be immediately removed from working at Guam Community College and the President shall be informed within twenty-four (24) hours. Failure to take corrective action after notice may result in the temporary suspension of the Agreement at the discretion of the Government.

() 54. DAVIS-BACON AND RELATED ACTS:

This is a Federally Funded Project – Contractor is required to comply with the Davis Bacon and Related Acts (DBRA), which requires all contractors and subcontractors performing work on federal construction projects or federally assisted contracts in excess of \$2,000 to pay their laborers and mechanics not less than the prevailing wage rate and fringe benefits for corresponding classes of laborers and mechanics employed on similar projects in the area. The prevailing wage rates and fringe benefits are determined by the Secretary of Labor for inclusion in covered contracts.

RECORDKEEPING – Under the Davis-Bacon and Related Acts, covered contractors must maintain payrolls and basic records and submit certified weekly payrolls. Although use of Form WH-347 is optional, the form will satisfy the requirements of Regulations, Parts 3 and 5 (29CFR, Subtitle A), as to payrolls submitted in connection with contracts subject to the DBRA. Records to be maintained include: Name, address, and social security number of each employee; each employee's work classification(s); hourly rate(s) of pay (including rates of contributions or cost anticipated for bona fide fringe benefits or cash equivalents thereof; Daily and weekly number of hours worked; Deductions made and Actual wages paid.

() 55. COMPLIANCE WITH THE NATIONAL DEFENSE AUTHORIZATION ACT (NDAA) AND SPECIFICALLY SECTION 889:

Section 889 aims to protect National Security by limiting the government's access to "covered" equipment or services manufactured or provided by certain companies or their subsidiaries or affiliates with know ties to the People's Republic of China.

(X) 56. CONTACT FOR CONTRACT ADMINISTRATION:

If your firm receives a contract as a result of this Solicitation, please designate a person whom we may contact for prompt administration.

Name:	<u>Aileen de Dios</u>	Title:	<u>General Manager</u>
Address:	<u>PO Box 217881</u> <u>Barrigada Guam</u> <u>96921</u>	Telephone:	<u>671.632.1179</u>

GOVERNMENT OF GUAM

GUAM COMMUNITY COLLEGE
P.O. BOX 23069 GMF
BARRIGADA, GUAM 96921

BID BOND NO. N/A

Luis E. Bustamante

KNOW ALL MEN BY THESE PRESENTS that dba: JJ Global Services, as Principal hereinafter called the Principal, and (Bonding Company), Aioi Nissay Dowa Insurance Company Ltd., a duly admitted insurer under the laws of the Territory of Guam, as Surety, hereinafter called the Surety are held firmly bound unto) the Territory of Guam for the sum of Fifteen Percent (15%) of Total Bid Amount Dollars (\$15% of Total Bid), for payment of which sum will and truly to be made, the said(Principal and the said Surety bind ourselves, our heirs, executors, administrators, successors and assigns, jointly and severally, firmly by these presents.

WHEREAS, the Principal has submitted a bid for (*identify project by number and brief description*) GCC-FB-21-009; Replacement of Building 900 Metal Awning Structure

NOW THEREFORE, if the Territory of Guam shall accept the bid of the Principal and the Principal shall enter into a Contract with the Territory of Guam in accordance with the terms of such bid, and give such bond or bonds as may be specified in bidding or Contract Documents with good and sufficient surety for the faithful performance of such Contract and for the prompt payment of labor and material furnished in the prosecution, thereof, or in the event of the failure of the Principal to enter such Contract and give such bond or bonds, if the Principal shall pay to the Territory of Guam the difference not to exceed the penalty hereof between the amounts specified in said bid and such larger amount for which the Territory of Guam may in good faith contract with another party to perform work covered by said bid or an appropriate liquidated amount as specified in the Invitation for Bids then this obligation shall be null and void, otherwise to remain in full force and effect.

Signed and sealed this 1st day of June 20 21

Luis E. Bustamante dba: JJ Global Services

(PRINCIPAL) (SEAL)



(WITNESS)



(TITLE)
Jo Takagi for Hideshi Matsui
(MAJOR OFFICER OF SURETY)

Executive Officer

(TITLE)



(MAJOR OFFICER OF SURETY)

General Manager Int'l Dept

(TITLE)

Takagi & Associates, Inc.

(RESIDENT GENERAL AGENT)

SEE INSTRUCTIONS IN BACK PAGE FOR SUPPORTING DOCUMENTS REQUIRED
DOA 113/Rev 4-1-87

GCC PR0109

POWER OF ATTORNEY

KNOW ALL MEN BY THESE PRESENTS

That AIOI NISSAY DOWA INSURANCE COMPANY LTD., a corporation of the State of Japan, having its principal office in the city of Tokyo, Japan, does hereby appoint, HIDENOBU TAKAGI, JO TAKAGI, YAMAZAKI A. GONZ, ALL OF THE CITY OF TUMON, GUAM, its true and lawful attorney, with full authority to execute on its behalf as surety, bonds, undertakings and contracts of suretyship thereof, issued in the course of its business and to bind the Company thereby, in an amount not to exceed \$***10,000,000Dollars***.

This Power of Attorney is granted and is signed and sealed by facsimile under and by the authority of the following Resolution adopted by the Board of Directors of the Company on the 21st day of September 1990.

RESOLVED, that the President, an Executive Vice President or a Senior Managing Director or a Managing Director or an Associate Director of the Company, shall have the power and authority to appoint Attorney and to authorize them to execute on behalf of the Company and attach the seal of the Company hereto to surety, bonds, undertakings and contracts of suretyship.

RESOLVED FURTHER, that the signatures of such Directors and the seal of the Company may be affixed to any such Power of Attorney or certificate relating therein by facsimile, and any such Power of Attorney or certificate bearing such facsimile signatures or facsimile seal shall be valid and binding upon the Company in the future with respect to any surety, bonds, undertakings and contracts of suretyship."

I, Hideaki Matsui, being duly sworn, depose and say that I am the Executive Officer of Aioi Nissay Dowa Insurance Company Limited and that this Power of Attorney set forth herein is true and correct to the best of my information, knowledge and belief.



Hideaki Matsui
Executive Officer

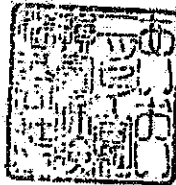

Subscribed and sworn before me this 13th day of July, 2017

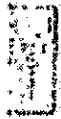

NOTARIAL CERTIFICATE

This is to certify that Kei Nemoto, an agent of Hideshi Matsui,
Executive Officer of Aioi Nissay Dowa Insurance Co., Ltd., and
Hiroyuki Muto, General Manager of International Department of
Aioi Nissay Dowa Insurance Co., Ltd., have stated in my presence that
the said Hideshi Matsui and Hiroyuki Muto acknowledged themselves
to have signed on the attached document.

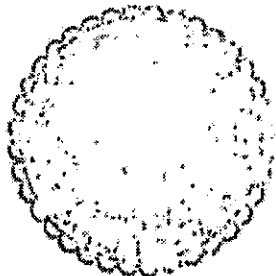

JUL 24 2017

Hayabusa Ohida



NOTARY PUBLIC
JAPAN

**GOVERNMENT OF GUAM
DEPARTMENT OF REVENUE AND TAXATION
OFFICE OF THE BANKING AND INSURANCE COMMISSIONER
CERTIFICATE OF AUTHORITY
RENEWAL COAJ72**

Know All Men By These Presents That:

Name **AIOINISSAY DOWA INSURANCE COMPANY LIMITED**

Address **1-28-1, EBISU,
TOKYO, 150-8488 JAPAN, . .**

SHIBUYA-KU

**Classes of Insurance
Authorized**

Accident & Health
Fidelity & Surety
Fire
Marine
Miscellaneous

Motor Vehicle
Prop. Damage & Liability
Workmens Comp

*Having complied with the Insurance Law of Guam, is hereby authorized to transact as an insurer, the above named
Classes of Insurance in Guam from the 1st day of July, 2020 to the 1st day of July, 2021
unless authority is revoked for failure to comply with the law.*

**General Agent(s):
TAKAGI & ASSOCIATES INC**

*In Witness Whereof, I have hereunto subscribed my
name officially and have hereon impressed my Seal of
Office at the City of Hagatña, Guam on this
1st day of July, 2020*

D. DAFNE MANSAPIT-SHIMIZU
Acting Banking & Insurance Commissioner

AFFIDAVIT DISCLOSING OWNERSHIP AND COMMISSIONS

CITY OF Tamuning)
) SS.
 ISLAND OF GUAM)

A. I, the undersigned, being first duly sworn, depose and say that I am an authorized representative of the offeror and that *[please check only one]*:

The offeror is an individual or sole proprietor and owns the entire (100%) interest in the offering business.

The offeror is a corporation, partnership, joint venture, or association known as _____ *[please state name of offeror company]*, and the persons, companies, partners, or joint venturers who have held more than 10% of the shares or interest in the offering business during the 365 days immediately preceding the submission date of the proposal are as follows *[if none, please so state]*:

<u>Name</u>	<u>Address</u>	<u>% of Interest</u>
N/A		

B. Further, I say that the persons who have received or are entitled to receive a commission, gratuity or other compensation for procuring or assisting in obtaining business related to the bid or proposal for which this affidavit is submitted are as follows *[if none, please so state]*:

<u>Name</u>	<u>Address</u>	<u>Compensation</u>
N/A		

C. If the ownership of the offering business should change between the time this affidavit is made and the time an award is made or a contract is entered into, then I promise personally to update the disclosure required by 5 GCA §5233 by delivering another affidavit to the government.

 Signature of one of the following:

Offeror, if the offeror is an individual;
 Partner, if the offeror is a partnership;
 Officer, if the offeror is a corporation.

Subscribed and sworn to before me
 this 1st day of June, 2021.

 NOTARY PUBLIC
 My commission expires: Dec 10, 2022

AFFIDAVIT RE NON-COLLUSION

CITY OF Tamuning)
) SS.
ISLAND OF GUAM)

Luis E. Bustamante [state name of affiant signing below], being first duly sworn, deposes and says that:

1. The name of the offering company or individual is [state name of company]
JJ Global Services

2. The proposal for the solicitation identified above is genuine and not collusive or a sham. The offeror has not colluded, conspired, connived or agreed, directly or indirectly, with any other offeror or person, to put in a sham proposal or to refrain from making an offer. The offeror has not in any manner, directly or indirectly, sought by an agreement or collusion, or communication or conference, with any person to fix the proposal price of offeror or of any other offeror, or to fix any overhead, profit or cost element of said proposal price, or of that of any other offeror, or to secure any advantage against the government of Guam or any other offeror, or to secure any advantage against the government of Guam or any person interested in the proposed contract. All statements in this affidavit and in the proposal are true to the best of the knowledge of the undersigned. This statement is made pursuant to 2 GAR Division 4 § 3126(b).

3. I make this statement on behalf of myself as a representative of the offeror, and on behalf of the offeror's officers, representatives, agents, subcontractors, and employees.

Luis E. Bustamante
Signature of one of the following:

Offeror, if the offeror is an individual;
Partner, if the offeror is a partnership;
Officer, if the offeror is a corporation.

Subscribed and sworn to before me

this 12 day of June, 2024.

[Signature]
NOTARY PUBLIC
My commission expires Dec 10, 2025

AFFIDAVIT RE GRATUITIES OR KICKBACKS

CITY OF Tamuning)
) SS.
ISLAND OF GUAM)

Luis E. Bustamante [state name of affiant signing below], being first duly sworn, deposes and says that:

1. The name of the offering firm or individual is [state name of offeror company] JJ Global Services. Affiant is offeror [state one of the following: the offeror, a partner of the offeror, an officer of the offeror] making the foregoing identified bid or proposal.

2. To the best of affiant's knowledge, neither affiant, nor any of the offeror's officers, representatives, agents, subcontractors, or employees have violated, are violating the prohibition against gratuities and kickbacks set forth in 2 GAR Division 4 § 11107(c). Further, affiant promises, on behalf of offeror, not to violate the prohibition against gratuities and kickbacks as set forth in 2 GAR Division 4 § 11107(e).

3. To the best of affiant's knowledge, neither affiant, nor any of the offeror's officers, representatives, agents, subcontractors, or employees have offered, given or agreed to give, any government of Guam employee or former government employee, any payment, gift, kickback, gratuity or offer of employment in connection with the offeror's proposal.

4. I make these statements on behalf of myself as a representative of the offeror, and on behalf of the offeror's officers, representatives, agents, subcontractors, and employees.

Luis E. Bustamante
Signature of one of the following:

Offeror, if the offeror is an individual;
Partner, if the offeror is a partnership;
Officer, if the offeror is a corporation.

Subscribed and sworn to before me
this 10 day of June, 2021.

[Signature]
NOTARY PUBLIC
My commission expires Dec 20, 2022.

AFFIDAVIT RE ETHICAL STANDARDS

CITY OF Tamuning)
) SS.
ISLAND OF GUAM)

Luis E. Bustamante [state name of affiant signing below], being first
duly sworn, deposes and says that:

The affiant is offeror [state one of the following: the offeror, a
partner of the offeror, an officer of the offeror] making the foregoing identified bid or proposal. To the best
of affiant's knowledge, neither affiant nor any officers, representatives, agents, subcontractors or employees
of offeror have knowingly influenced any government of Guam employee to breach any of the ethical
standards set forth in 5 GCA Chapter 5, Article 11. Further, affiant promises that neither he or she, nor any
officer, representative, agent, subcontractor, or employee of offeror will knowingly influence any
government of Guam employee to breach any ethical standards set forth in 5 GCA Chapter 5, Article 11.
These statements are made pursuant to 2 GAR Division 4 § 11103(b).

Luis E. Bustamante
Signature of one of the following:

Offeror, if the offeror is an individual;
Partner, if the offeror is a partnership;
Officer, if the offeror is a corporation.

Subscribed and sworn to before me
this 10 day of June, 2021.

Thomas Sales
NOTARY PUBLIC
My commission expires Dec 00, 2022.

DECLARATION RE COMPLIANCE WITH U.S. DOL WAGE DETERMINATION

Procurement No.: GCC-FB-21-009

Name of Offeror Company: JJ Global Services

I, Luis E. Bustamante hereby certify under penalty of perjury:

(1) That I am offeror [please select one: the offeror, a partner of the offeror, an officer of the offeror] making the bid or proposal in the foregoing identified procurement;

(2) That I have read and understand the provisions of 5 GCA § 5801 and § 5802 which read:

§ 5801. Wage Determination Established.

In such cases where the government of Guam enters into contractual arrangements with a sole proprietorship, a partnership or a corporation ("contractor") for the provision of a service to the government of Guam, and in such cases where the contractor employs a person(s) whose purpose, in whole or in part, is the direct delivery of service contracted by the government of Guam, then the contractor shall pay such employee(s) in accordance with the Wage Determination for Guam and the Northern Mariana Islands issued and promulgated by the U.S. Department of Labor for such labor as is employed in the direct delivery of contract deliverables to the government of Guam.

The Wage Determination most recently issued by the U.S. Department of Labor at the time a contract is awarded to a contractor by the government of Guam shall be used to determine wages, which shall be paid to employees pursuant to this Article. Should any contract contain a renewal clause, then at the time of renewal adjustments, there shall be made stipulations contained in that contract for applying the Wage Determination, as required by this Article, so that the Wage Determination promulgated by the U.S. Department of Labor on a date most recent to the renewal date shall apply.

§ 5802. Benefits.

In addition to the Wage Determination detailed in this Article, any contract to which this Article applies shall also contain provisions mandating health and similar benefits for employees covered by this Article, such benefits having a minimum value as detailed in the Wage Determination issued and promulgated by the U.S. Department of Labor, and shall contain provisions guaranteeing a minimum of ten (10) paid holidays per annum per employee.

(3) That the offeror is in full compliance with 5 GCA § 5801 and § 5802, as may be applicable to the procurement referenced herein;

(4) That I have attached the most recent wage determination applicable to Guam issued by the U.S. Department of Labor. [INSTRUCTIONS - Please attach!]

Signature

"REGISTER OF WAGE DETERMINATIONS UNDER
THE SERVICE CONTRACT ACT
By direction of the Secretary of Labor

U.S. DEPARTMENT OF LABOR
EMPLOYMENT STANDARDS ADMINISTRATION
WAGE AND HOUR DIVISION
WASHINGTON D.C. 20210

Daniel W. Simms
Director

Division of
Wage Determinations

Wage Determination No.: 2015-5693
Revision No.: 12
Date Of Last Revision: 12/21/2020

Note: Under Executive Order (EO) 13658 an hourly minimum wage of \$10.95 for calendar year 2021 applies to all contracts subject to the Service Contract Act for which the contract is awarded (and any solicitation was issued) on or after January 1 2015. If this contract is covered by the EO the contractor must pay all workers in any classification listed on this wage determination at least \$10.95 per hour (or the applicable wage rate listed on this wage determination if it is higher) for all hours spent performing on the contract in calendar year 2021. The EO minimum wage rate will be adjusted annually. Additional information on contractor requirements and worker protections under the EO is available at www.dol.gov/whd/govcontracts.

States: Guam Northern Marianas Wake Island

Area: Guam Statewide

Northern Marianas Statewide

Wake Island Statewide

****Fringe Benefits Required Follow the Occupational Listing****

OCCUPATION CODE - TITLE	FOOTNOTE	RATE
01000 - Administrative Support And Clerical Occupations		
01011 - Accounting Clerk I		13.57
01012 - Accounting Clerk II		15.23
01013 - Accounting Clerk III		17.04
01020 - Administrative Assistant		21.43
01035 - Court Reporter		17.40
01041 - Customer Service Representative I		11.51
01042 - Customer Service Representative II		12.94
01043 - Customer Service Representative III		14.12
01051 - Data Entry Operator I		12.15
01052 - Data Entry Operator II		13.25
01060 - Dispatcher Motor Vehicle		15.81

01070 - Document Preparation Clerk	13.85
01090 - Duplicating Machine Operator	13.85
01111 - General Clerk I	10.35
01112 - General Clerk II	11.29
01113 - General Clerk III	12.68
01120 - Housing Referral Assistant	19.39
01141 - Messenger Courier	11.37
01191 - Order Clerk I	12.57
01192 - Order Clerk II	13.71
01261 - Personnel Assistant (Employment) I	15.95
01262 - Personnel Assistant (Employment) II	17.85
01263 - Personnel Assistant (Employment) III	19.89
01270 - Production Control Clerk	21.78
01290 - Rental Clerk	11.10
01300 - Scheduler Maintenance	15.55
01311 - Secretary I	15.55
01312 - Secretary II	17.40
01313 - Secretary III	19.39
01320 - Service Order Dispatcher	14.00
01410 - Supply Technician	21.43
01420 - Survey Worker	16.79
01460 - Switchboard Operator/Receptionist	9.67
01531 - Travel Clerk I	13.01
01532 - Travel Clerk II	14.12
01533 - Travel Clerk III	15.09
01611 - Word Processor I	14.53
01612 - Word Processor II	16.31
01613 - Word Processor III	18.26
05000 - Automotive Service Occupations	
05005 - Automobile Body Repairer Fiberglass	14.82
05010 - Automotive Electrician	13.92
05040 - Automotive Glass Installer	13.02
05070 - Automotive Worker	13.02
05110 - Mobile Equipment Servicer	11.16
05130 - Motor Equipment Metal Mechanic	14.82
05160 - Motor Equipment Metal Worker	13.02
05190 - Motor Vehicle Mechanic	14.82
05220 - Motor Vehicle Mechanic Helper	10.22
05250 - Motor Vehicle Upholstery Worker	12.11
05280 - Motor Vehicle Wrecker	13.02
05310 - Painter Automotive	13.92
05340 - Radiator Repair Specialist	13.02
05370 - Tire Repairer	12.34
05400 - Transmission Repair Specialist	14.82
07000 - Food Preparation And Service Occupations	
07010 - Baker	10.47
07041 - Cook I	12.05
07042 - Cook II	14.05
07070 - Dishwasher	9.28
07130 - Food Service Worker	9.34

07210 - Meat Cutter	11.86
07260 - Waiter/Waitress	9.23
09000 - Furniture Maintenance And Repair Occupations	
09010 - Electrostatic Spray Painter	18.04
09040 - Furniture Handler	10.95
09080 - Furniture Refinisher	18.04
09090 - Furniture Refinisher Helper	13.27
09110 - Furniture Repairer Minor	15.70
09130 - Upholsterer	18.04
11000 - General Services And Support Occupations	
11030 - Cleaner Vehicles	9.35
11060 - Elevator Operator	9.35
11090 - Gardener	13.00
11122 - Housekeeping Aide	9.44
11150 - Janitor	9.44
11210 - Laborer Grounds Maintenance	9.82
11240 - Maid or Houseman	9.26
11260 - Pruner	8.79
11270 - Tractor Operator	11.90
11330 - Trail Maintenance Worker	9.82
11360 - Window Cleaner	10.54
12000 - Health Occupations	
12010 - Ambulance Driver	17.77
12011 - Breath Alcohol Technician	17.77
12012 - Certified Occupational Therapist Assistant	24.38
12015 - Certified Physical Therapist Assistant	24.38
12020 - Dental Assistant	15.02
12025 - Dental Hygienist	32.84
12030 - EKG Technician	25.99
12035 - Electroneurodiagnostic Technologist	25.99
12040 - Emergency Medical Technician	17.77
12071 - Licensed Practical Nurse I	15.88
12072 - Licensed Practical Nurse II	17.77
12073 - Licensed Practical Nurse III	19.81
12100 - Medical Assistant	12.26
12130 - Medical Laboratory Technician	18.82
12160 - Medical Record Clerk	13.61
12190 - Medical Record Technician	17.77
12195 - Medical Transcriptionist	15.88
12210 - Nuclear Medicine Technologist	39.04
12221 - Nursing Assistant I	11.34
12222 - Nursing Assistant II	12.75
12223 - Nursing Assistant III	13.91
12224 - Nursing Assistant IV	15.61
12235 - Optical Dispenser	17.77
12236 - Optical Technician	15.88
12250 - Pharmacy Technician	15.49
12280 - Phlebotomist	15.33
12305 - Radiologic Technologist	23.03
12311 - Registered Nurse I	22.53

12312 - Registered Nurse II	27.56
12313 - Registered Nurse II Specialist	27.56
12314 - Registered Nurse III	33.34
12315 - Registered Nurse III Anesthetist	33.34
12316 - Registered Nurse IV	39.96
12317 - Scheduler (Drug and Alcohol Testing)	22.01
12320 - Substance Abuse Treatment Counselor	22.01
13000 - Information And Arts Occupations	
13011 - Exhibits Specialist I	20.35
13012 - Exhibits Specialist II	25.20
13013 - Exhibits Specialist III	30.83
13041 - Illustrator I	20.35
13042 - Illustrator II	25.20
13043 - Illustrator III	30.83
13047 - Librarian	27.91
13050 - Library Aide/Clerk	16.20
13054 - Library Information Technology Systems Administrator	25.20
13058 - Library Technician	16.64
13061 - Media Specialist I	18.18
13062 - Media Specialist II	20.35
13063 - Media Specialist III	22.68
13071 - Photographer I	18.18
13072 - Photographer II	20.35
13073 - Photographer III	25.20
13074 - Photographer IV	30.83
13075 - Photographer V	37.30
13090 - Technical Order Library Clerk	20.35
13110 - Video Teleconference Technician	17.38
14000 - Information Technology Occupations	
14041 - Computer Operator I	15.71
14042 - Computer Operator II	17.22
14043 - Computer Operator III	19.19
14044 - Computer Operator IV	21.33
14045 - Computer Operator V	23.62
14071 - Computer Programmer I	(see 1) 15.73
14072 - Computer Programmer II	(see 1) 19.50
14073 - Computer Programmer III	(see 1) 23.84
14074 - Computer Programmer IV	(see 1)
14101 - Computer Systems Analyst I	(see 1) 24.23
14102 - Computer Systems Analyst II	(see 1)
14103 - Computer Systems Analyst III	(see 1)
14150 - Peripheral Equipment Operator	15.71
14160 - Personal Computer Support Technician	21.33
14170 - System Support Specialist	21.24
15000 - Instructional Occupations	
15010 - Aircrew Training Devices Instructor (Non-Rated)	24.23
15020 - Aircrew Training Devices Instructor (Rated)	29.32
15030 - Air Crew Training Devices Instructor (Pilot)	34.91
15050 - Computer Based Training Specialist / Instructor	24.23

15060 - Educational Technologist	27.61
15070 - Flight Instructor (Pilot)	34.91
15080 - Graphic Artist	20.47
15085 - Maintenance Test Pilot Fixed Jet/Prop	34.91
15086 - Maintenance Test Pilot Rotary Wing	34.91
15088 - Non-Maintenance Test/Co-Pilot	34.91
15090 - Technical Instructor	17.67
15095 - Technical Instructor/Course Developer	21.62
15110 - Test Proctor	14.27
15120 - Tutor	14.27
16000 - Laundry Dry-Cleaning Pressing And Related Occupations	
16010 - Assembler	9.88
16030 - Counter Attendant	9.88
16040 - Dry Cleaner	11.30
16070 - Finisher Flatwork Machine	9.88
16090 - Presser Hand	9.88
16110 - Presser Machine Drycleaning	9.88
16130 - Presser Machine Shirts	9.88
16160 - Presser Machine Wearing Apparel Laundry	9.88
16190 - Sewing Machine Operator	11.94
16220 - Tailor	12.44
16250 - Washer Machine	10.36
19000 - Machine Tool Operation And Repair Occupations	
19010 - Machine-Tool Operator (Tool Room)	18.04
19040 - Tool And Die Maker	22.67
21000 - Materials Handling And Packing Occupations	
21020 - Forklift Operator	13.96
21030 - Material Coordinator	21.78
21040 - Material Expediter	21.78
21050 - Material Handling Laborer	11.37
21071 - Order Filler	9.66
21080 - Production Line Worker (Food Processing)	13.96
21110 - Shipping Packer	15.92
21130 - Shipping/Receiving Clerk	15.92
21140 - Store Worker I	14.76
21150 - Stock Clerk	20.75
21210 - Tools And Parts Attendant	13.96
21410 - Warehouse Specialist	13.96
23000 - Mechanics And Maintenance And Repair Occupations	
23010 - Aerospace Structural Welder	22.76
23019 - Aircraft Logs and Records Technician	17.70
23021 - Aircraft Mechanic I	21.67
23022 - Aircraft Mechanic II	22.76
23023 - Aircraft Mechanic III	23.91
23040 - Aircraft Mechanic Helper	15.07
23050 - Aircraft Painter	20.35
23060 - Aircraft Servicer	17.70
23070 - Aircraft Survival Flight Equipment Technician	20.35
23080 - Aircraft Worker	19.12
23091 - Aircrew Life Support Equipment (ALSE) Mechanic	19.12

I		
23092	- Aircrew Life Support Equipment (ALSE) Mechanic	21.67
II		
23110	- Appliance Mechanic	18.04
23120	- Bicycle Repairer	14.49
23125	- Cable Splicer	19.59
23130	- Carpenter Maintenance	16.07
23140	- Carpet Layer	16.86
23160	- Electrician Maintenance	18.05
23181	- Electronics Technician Maintenance I	16.86
23182	- Electronics Technician Maintenance II	18.04
23183	- Electronics Technician Maintenance III	19.55
23260	- Fabric Worker	15.70
23290	- Fire Alarm System Mechanic	15.43
23310	- Fire Extinguisher Repairer	14.49
23311	- Fuel Distribution System Mechanic	19.21
23312	- Fuel Distribution System Operator	14.49
23370	- General Maintenance Worker	11.96
23380	- Ground Support Equipment Mechanic	21.67
23381	- Ground Support Equipment Servicer	17.70
23382	- Ground Support Equipment Worker	19.12
23391	- Gunsmith I	14.49
23392	- Gunsmith II	16.86
23393	- Gunsmith III	19.21
23410	- Heating Ventilation And Air-Conditioning Mechanic	17.16
23411	- Heating Ventilation And Air Contidioning Mechanic (Research Facility)	18.25
23430	- Heavy Equipment Mechanic	18.35
23440	- Heavy Equipment Operator	17.12
23460	- Instrument Mechanic	19.21
23465	- Laboratory/Shelter Mechanic	18.04
23470	- Laborer	11.37
23510	- Locksmith	18.04
23530	- Machinery Maintenance Mechanic	23.13
23550	- Machinist Maintenance	19.21
23580	- Maintenance Trades Helper	10.67
23591	- Metrology Technician I	19.21
23592	- Metrology Technician II	20.42
23593	- Metrology Technician III	21.63
23640	- Millwright	19.21
23710	- Office Appliance Repairer	18.04
23760	- Painter Maintenance	13.95
23790	- Pipefitter Maintenance	18.39
23810	- Plumber Maintenance	17.27
23820	- Pneudraulic Systems Mechanic	19.21
23850	- Rigger	19.21
23870	- Scale Mechanic	16.86
23890	- Sheet-Metal Worker Maintenance	16.09
23910	- Small Engine Mechanic	16.86

23931 - Telecommunications Mechanic I	19.01
23932 - Telecommunications Mechanic II	19.91
23950 - Telephone Lineman	18.24
23960 - Welder Combination Maintenance	17.95
23965 - Well Driller	19.21
23970 - Woodcraft Worker	19.21
23980 - Woodworker	14.49
24000 - Personal Needs Occupations	
24550 - Case Manager	14.72
24570 - Child Care Attendant	10.09
24580 - Child Care Center Clerk	13.25
24610 - Chore Aide	11.62
24620 - Family Readiness And Support Services Coordinator	14.72
24630 - Homemaker	16.12
25000 - Plant And System Operations Occupations	
25010 - Boiler Tender	19.21
25040 - Sewage Plant Operator	21.59
25070 - Stationary Engineer	19.21
25190 - Ventilation Equipment Tender	13.27
25210 - Water Treatment Plant Operator	21.59
27000 - Protective Service Occupations	
27004 - Alarm Monitor	10.90
27007 - Baggage Inspector	9.40
27008 - Corrections Officer	12.05
27010 - Court Security Officer	12.05
27030 - Detection Dog Handler	10.90
27040 - Detention Officer	12.05
27070 - Firefighter	12.05
27101 - Guard I	9.40
27102 - Guard II	10.90
27131 - Police Officer I	12.05
27132 - Police Officer II	13.40
28000 - Recreation Occupations	
28041 - Carnival Equipment Operator	12.79
28042 - Carnival Equipment Repairer	13.97
28043 - Carnival Worker	9.45
28210 - Gate Attendant/Gate Tender	13.18
28310 - Lifeguard	11.01
28350 - Park Attendant (Aide)	14.74
28510 - Recreation Aide/Health Facility Attendant	11.84
28515 - Recreation Specialist	18.26
28630 - Sports Official	11.74
28690 - Swimming Pool Operator	17.71
29000 - Stevedoring/Longshoremen Occupational Services	
29010 - Blocker And Bracer	23.62
29020 - Hatch Tender	23.62
29030 - Line Handler	23.62
29041 - Stevedore I	21.98
29042 - Stevedore II	25.26

30000	- Technical Occupations	
30010	- Air Traffic Control Specialist Center (HFO) (see 2)	39.89
30011	- Air Traffic Control Specialist Station (HFO) (see 2)	27.50
30012	- Air Traffic Control Specialist Terminal (HFO) (see 2)	30.29
30021	- Archeological Technician I	17.49
30022	- Archeological Technician II	19.56
30023	- Archeological Technician III	24.21
30030	- Cartographic Technician	23.18
30040	- Civil Engineering Technician	23.08
30051	- Cryogenic Technician I	25.57
30052	- Cryogenic Technician II	28.24
30061	- Drafter/CAD Operator I	17.49
30062	- Drafter/CAD Operator II	19.56
30063	- Drafter/CAD Operator III	20.77
30064	- Drafter/CAD Operator IV	25.57
30081	- Engineering Technician I	14.84
30082	- Engineering Technician II	16.66
30083	- Engineering Technician III	18.64
30084	- Engineering Technician IV	23.08
30085	- Engineering Technician V	28.24
30086	- Engineering Technician VI	34.16
30090	- Environmental Technician	23.08
30095	- Evidence Control Specialist	23.08
30210	- Laboratory Technician	20.77
30221	- Latent Fingerprint Technician I	25.57
30222	- Latent Fingerprint Technician II	28.24
30240	- Mathematical Technician	23.34
30361	- Paralegal/Legal Assistant I	19.44
30362	- Paralegal/Legal Assistant II	23.94
30363	- Paralegal/Legal Assistant III	29.29
30364	- Paralegal/Legal Assistant IV	35.44
30375	- Petroleum Supply Specialist	28.24
30390	- Photo-Optics Technician	21.93
30395	- Radiation Control Technician	28.24
30461	- Technical Writer I	23.08
30462	- Technical Writer II	28.24
30463	- Technical Writer III	34.16
30491	- Unexploded Ordnance (UXO) Technician I	25.35
30492	- Unexploded Ordnance (UXO) Technician II	30.67
30493	- Unexploded Ordnance (UXO) Technician III	36.76
30494	- Unexploded (UXO) Safety Escort	25.35
30495	- Unexploded (UXO) Sweep Personnel	25.35
30501	- Weather Forecaster I	25.57
30502	- Weather Forecaster II	31.09
30620	- Weather Observer Combined Upper Air Or Surface Programs	(see 2) 20.77
30621	- Weather Observer Senior	(see 2) 23.08
31000	- Transportation/Mobile Equipment Operation Occupations	
31010	- Airplane Pilot	30.67
31020	- Bus Aide	8.15

31030 - Bus Driver	9.69
31043 - Driver Courier	9.69
31260 - Parking and Lot Attendant	9.91
31290 - Shuttle Bus Driver	10.59
31310 - Taxi Driver	10.37
31361 - Truckdriver Light	10.59
31362 - Truckdriver Medium	11.61
31363 - Truckdriver Heavy	13.92
31364 - Truckdriver Tractor-Trailer	13.92
99000 - Miscellaneous Occupations	
99020 - Cabin Safety Specialist	14.95
99030 - Cashier	9.48
99050 - Desk Clerk	9.70
99095 - Embalmer	25.35
99130 - Flight Follower	25.35
99251 - Laboratory Animal Caretaker I	22.67
99252 - Laboratory Animal Caretaker II	24.77
99260 - Marketing Analyst	21.54
99310 - Mortician	25.35
99410 - Pest Controller	14.61
99510 - Photofinishing Worker	13.32
99710 - Recycling Laborer	15.75
99711 - Recycling Specialist	21.66
99730 - Refuse Collector	14.91
99810 - Sales Clerk	9.66
99820 - School Crossing Guard	16.75
99830 - Survey Party Chief	22.02
99831 - Surveying Aide	12.52
99832 - Surveying Technician	16.27
99840 - Vending Machine Attendant	22.67
99841 - Vending Machine Repairer	28.88
99842 - Vending Machine Repairer Helper	22.67

Note: Executive Order (EO) 13706 Establishing Paid Sick Leave for Federal Contractors applies to all contracts subject to the Service Contract Act for which the contract is awarded (and any solicitation was issued) on or after January 1 2017. If this contract is covered by the EO the contractor must provide employees with 1 hour of paid sick leave for every 30 hours they work up to 56 hours of paid sick leave each year. Employees must be permitted to use paid sick leave for their own illness injury or other health-related needs including preventive care; to assist a family member (or person who is like family to the employee) who is ill

injured or has other health-related needs including preventive care; or for reasons resulting from or to assist a family member (or person who is like family to the employee) who is the victim of domestic violence sexual assault or stalking. Additional information on contractor requirements and worker protections under the EO is available at www.dol.gov/whd/govcontracts.

ALL OCCUPATIONS LISTED ABOVE RECEIVE THE FOLLOWING BENEFITS:

HEALTH & WELFARE: \$4.54 per hour up to 40 hours per week or \$181.60 per week or \$786.93 per month

HEALTH & WELFARE EO 13706: \$4.22 per hour up to 40 hours per week or \$168.80 per week or \$731.47 per month*

*This rate is to be used only when compensating employees for performance on an SCA-covered contract also covered by EO 13706 Establishing Paid Sick Leave for Federal Contractors. A contractor may not receive credit toward its SCA obligations for any

paid sick leave provided pursuant to EO 13706.

VACATION: 2 weeks paid vacation after 1 year of service with a contractor or successor; and 4 weeks after 3 years. Length of service includes the whole span of continuous service with the present contractor or successor wherever employed and with the predecessor contractors in the performance of similar work at the same Federal facility. (Reg. 29 CFR 4.173)

HOLIDAYS: A minimum of ten paid holidays per year: New Year's Day Martin Luther King Jr.'s Birthday Washington's Birthday Memorial Day Independence Day Labor Day Columbus Day Veterans' Day Thanksgiving Day and Christmas Day. (A contractor may substitute for any of the named holidays another day off with pay in accordance with a plan communicated to the employees involved.) (See 29 CFR 4.174)

THE OCCUPATIONS WHICH HAVE NUMBERED FOOTNOTES IN PARENTHESES RECEIVE THE FOLLOWING:

1) COMPUTER EMPLOYEES: Under the SCA at section 8(b) this wage determination does not apply to any employee who individually qualifies as a bona fide executive administrative or professional employee as defined in 29 C.F.R. Part 541. Because most Computer System Analysts and Computer Programmers who are compensated at a rate

not less than \$27.63 (or on a salary or fee basis at a rate not less than \$455 per week) an hour would likely qualify as exempt computer professionals (29 C.F.R. 541.400) wage rates may not be listed on this wage determination for all occupations within those job families. In addition because this wage determination may not list a wage rate for some or all occupations within those job families if the survey

data indicates that the prevailing wage rate for the occupation equals or exceeds \$27.63 per hour conformances may be necessary for certain nonexempt employees. For example if an individual employee is nonexempt but nevertheless performs duties within the scope of one of the Computer Systems Analyst or Computer Programmer occupations for which this wage determination does not specify an SCA wage rate then the wage rate for that employee must be conformed in accordance with the conformance procedures described in the conformance note included on this wage determination.

Additionally because job titles vary widely and change quickly in the computer industry job titles are not determinative of the application of the computer professional exemption. Therefore the exemption applies only to computer employees who satisfy the compensation requirements and whose primary duty consists of:

(1) The application of systems analysis techniques and procedures including consulting with users to determine hardware software or system functional specifications;

(2) The design development documentation analysis creation testing or modification of computer systems or programs including prototypes based on and related to user or system design specifications;

(3) The design documentation testing creation or modification of computer programs related to machine operating systems; or

(4) A combination of the aforementioned duties the performance of which requires the same level of skills. (29 C.F.R. 541.400).

2) AIR TRAFFIC CONTROLLERS AND WEATHER OBSERVERS - NIGHT PAY & SUNDAY PAY: If you work at night as part of a regular tour of duty you will earn a night differential and receive an additional 10% of basic pay for any hours worked between 6pm and 6am.

If you are a full-time employed (40 hours a week) and Sunday is part of your regularly scheduled workweek you are paid at your rate of basic pay plus a Sunday premium of 25% of your basic rate for each hour of Sunday work which is not overtime (i.e. occasional work on Sunday outside the normal tour of duty is considered overtime work).

**** HAZARDOUS PAY DIFFERENTIAL ****

An 8 percent differential is applicable to employees employed in a position that represents a high degree of hazard when working with or in close proximity to ordnance explosives and incendiary materials. This includes work such as screening blending drying mixing and pressing of sensitive ordnance explosives and pyrotechnic compositions such as lead azide black powder and photoflash powder.

All dry-house activities involving propellants or explosives. Demilitarization modification renovation demolition and maintenance operations on sensitive ordnance explosives and incendiary materials. All operations involving re-grading and cleaning of artillery ranges.

A 4 percent differential is applicable to employees employed in a position that represents a low degree of hazard when working with or in close proximity to ordnance (or employees possibly adjacent to) explosives and incendiary materials which involves potential injury such as laceration of hands face or arms of the employee engaged in the operation irritation of the skin minor burns and the like; minimal damage to immediate or adjacent work area or equipment being used. All operations involving unloading storage and hauling of ordnance explosive and incendiary ordnance material other than small arms ammunition. These differentials are only applicable to work that has been specifically designated by the agency for ordnance explosives and incendiary material differential pay.

**** UNIFORM ALLOWANCE ****

If employees are required to wear uniforms in the performance of this contract (either by the terms of the Government contract by the employer by the state or local law etc.) the cost of furnishing such uniforms and maintaining (by laundering or dry cleaning) such uniforms is an expense that may not be borne by an employee where such cost reduces the hourly rate below that required by the wage

determination. The Department of Labor will accept payment in accordance with the following standards as compliance:

The contractor or subcontractor is required to furnish all employees with an adequate number of uniforms without cost or to reimburse employees for the actual cost of the uniforms. In addition where uniform cleaning and maintenance is made the responsibility of the employee all contractors and subcontractors subject to this wage determination shall (in the absence of a bona fide collective bargaining agreement providing for a different amount or the furnishing of contrary affirmative proof as to the actual cost) reimburse all employees for such cleaning and maintenance at a rate of \$3.35 per week (or \$.67 cents per day). However in those instances where the uniforms furnished are made of "wash and wear" materials may be routinely washed and dried with other personal garments and do not require any special treatment such as dry cleaning daily washing or commercial laundering in order to meet the cleanliness or appearance standards set by the terms

of the Government contract by the contractor by law or by the nature of the work there is no requirement that employees be reimbursed for uniform maintenance costs.

**** SERVICE CONTRACT ACT DIRECTORY OF OCCUPATIONS ****

The duties of employees under job titles listed are those described in the "Service Contract Act Directory of Occupations" Fifth Edition (Revision 1) dated September 2015 unless otherwise indicated.

**** REQUEST FOR AUTHORIZATION OF ADDITIONAL CLASSIFICATION AND WAGE RATE Standard Form 1444 (SF-1444) ****

Conformance Process:

The contracting officer shall require that any class of service employee which is not listed herein and which is to be employed under the contract (i.e. the work to be performed is not performed by any classification listed in the wage determination) be classified by the contractor so as to provide a reasonable relationship (i.e. appropriate level of skill comparison) between such unlisted classifications and the classifications listed in the wage determination (See 29 CFR

4.6(b)(2)(1)). Such conforming procedures shall be initiated by the contractor

prior to the performance of contract work by such unlisted class(es) of employees (See 29 CFR 4.6(b)(2)(ii)). The Wage and Hour Division shall make a final determination of conformed classification wage rate and/or fringe benefits which shall be paid to all employees performing in the classification from the first day of work on which contract work is performed by them in the classification. Failure to pay such unlisted employees the compensation agreed upon by the interested parties and/or fully determined by the Wage and Hour Division retroactive to the date such class of employees commenced contract work shall be a violation of the Act and this contract. (See 29 CFR 4.6(b)(2)(v)). When multiple wage determinations are included in a contract a separate SF-1444 should be prepared for each wage determination to which a class(es) is to be conformed.

The process for preparing a conformance request is as follows:

- 1) When preparing the bid the contractor identifies the need for a conformed occupation(s) and computes a proposed rate(s).

- 2) After contract award the contractor prepares a written report listing in order the proposed classification title(s) a Federal grade equivalency (FGE) for each proposed classification(s) job description(s) and rationale for proposed wage rate(s) including information regarding the agreement or disagreement of the authorized representative of the employees involved or where there is no authorized representative the employees themselves. This report should be submitted to the contracting officer no later than 30 days after such unlisted class(es) of employees performs any contract work.

- 3) The contracting officer reviews the proposed action and promptly submits a report of the action together with the agency's recommendations and pertinent information including the position of the contractor and the employees to the U.S. Department of Labor Wage and Hour Division for review (See 29 CFR 4.6(b)(2)(ii)).

- 4) Within 30 days of receipt the Wage and Hour Division approves modifies or disapproves the action via transmittal to the agency contracting officer or notifies the contracting officer that additional time will be required to process the request.

5) The contracting officer transmits the Wage and Hour Division's decision to the contractor.

6) Each affected employee shall be furnished by the contractor with a written copy of such determination or it shall be posted as a part of the wage determination (See

29 CFR 4.6(b)(2)(iii)).

Information required by the Regulations must be submitted on SF-1444 or bond paper.

When preparing a conformance request the "Service Contract Act Directory of Occupations" should be used to compare job definitions to ensure that duties requested are not performed by a classification already listed in the wage determination. Remember it is not the job title but the required tasks that determine whether a class is included in an established wage determination. Conformances may not be used to artificially split combine or subdivide classifications listed in the wage determination (See 29 CFR 4.152(c)(1))."



**GCC Bid No:
GCC-FB-21-009**

**Bid Description:
Replacement of Building 900
Metal Awning Structure**

May 2021

Page 1 of 7

Guam Community College (GCC) is soliciting the service of a qualified contractor to replace the dilapidated awning structure located at building 900 and including (but not limited to) the following.

SCOPE OF WORK (SOW):

A. General Requirements of the Scope of Work:

The Qualified Contractor for this SOW shall:

1. Conduct a holistic assessment, verify existing conditions, and conduct all the necessary work for a design build concept to replace the dilapidated awning located at building 900 to include all component elements for complete functionality, operation, safety and code-compliance (i.e., civil, mechanical, infrastructure, etc.).
2. Provide contractual services to include at a minimum the following component elements – assessment, estimation, replacement requirements, certification, and as-build drawings
3. Ensure “good standings” with governing authorities having jurisdiction with the SOW (e.g., Guam Department of Public Works, Department of Revenue and Taxation, Guam Contractor’s License Board, etc.) prior to commencing work related to this SOW.
4. When appropriate, obtain and pay requisite permits, clearances, and approvals, from all applicable government of Guam agencies.
5. A mandatory site visit is scheduled for 10:00 a.m. at the project site on Wednesday, May 19, 2021. Contact Josephine Arceo at 735-5521 if accommodative service or an additional site visit is needed.
6. Warranty: Qualified Contractor shall assure against defective materials and workmanship by providing a one (1) year written Certificate of Warranty. The Certificate of Warranty shall commence immediately upon GCC’s explicit acceptance of the project. The Certificate of Warranty shall honor all product warranties and include the cost of all parts, workmanship, and related labor fees. Qualified Contractor must provide and honor all written product warranties.
7. When awarded, the Qualified Contractor shall submit a list and have all supplies and materials for GCC’s explicit approval prior to their use or installation. All supplies, materials, and incidentals included in this SOW shall be new and of the most suitable grade for the purpose intended.
8. Qualified Contractor’s employees assigned to this project shall be cleared from the Guam Sex Offender Registry and have a GCC badge clearly visible on his/her person.



**GCC Bid No:
GCC-FB-21-009**

**Bid Description:
Replacement of Building 900
Metal Awning Structure**

May 2021

Page 2 of 7

9. The Qualified Contractor shall conform to all Occupational Safety and Health Administration (OSHA) regulations, the National Electrical Code (NEC), Environmental Protection Agency and the National Fire Protection Association (NFPA). Clean, maintain, protect work site, and newly installed work as necessary throughout the project period. Provide suitable protective covering on newly installed work when reasonably required to mitigate damage (e.g., during inclement weather) until such time the project is accepted by GCC. Before commencing work, the Qualified Contractor shall coordinate and have in place necessary provisions to protect adjacent building properties for safety, to minimize disruptions and prevent ANY potential hazards. For example, relocate contents away from immediate work area to unoccupied location as work requirements dictate.
10. Properly dispose and recycle all waste, debris, rubbish, etc. associated with the project legally and off-site. Do not allow debris to accumulate at the project site.
11. Take all precautions to assure that GCC's stakeholders (students, employees, and visitors) remain out of harm's way throughout the project. The Qualified Contractor shall properly block off the project site and use appropriate signage.
12. GCC's hours of operation is Monday through Thursday, 7:30 a.m. to 10 p.m., Friday from 7:30 a.m. to 6:00 pm, and Saturday from 7:30 a.m. to 12 p.m. GCC also recognizes Government of Guam's holidays. The Qualified Contractor's request to work on campus outside of GCC's hours of operation must be preapproved by Planning and Development Department.
13. The Qualified Contractor and her/his employees shall adhere to GCC's Tobacco and Betel Nut (Pugu'a) Free Policy 175:
 - a. DO NOT use tobacco products while on Guam Community College property.
 - b. DO NOT use electronic cigarette (e-cigs) devices while on Guam Community College property.
 - c. DO NOT chew or spit pugu'a or chewing tobacco while on Guam Community College property.
14. The Qualified Contractor and her/his employees shall adhere to Public Health and GCC's COVID19 guidelines on campus at all times;
15. Correct defective work to meet SOW requirements.
16. The project is deemed complete by the Qualified Contractor's submission of all warranties, as-built, GCC's formal inspection, and GCC's acceptance of the project for its intended use.



**GCC Bid No:
GCC-FB-21-009**

**Bid Description:
Replacement of Building 900
Metal Awning Structure**

May 2021

Page 3 of 7

17. Submit a price proposal having an itemized cost such that GCC may award the project based on the "...lowest, most responsive..." price proposal based on the Scope of Work and related requirements (A. General Requirements of the Scope of Work and B. Specific Requirements of the Scope of Work).
18. Qualified Contractor shall deliver a complete price proposal packet to include the following (18a-18e):
- a. A Narrative (required document) describing how the Qualified Contractor will address this project's SOW;
 - b. A Critical Path Method (CPM) chart (required document) to illustrate the Qualified Contractor's timeline to complete the project within ninety (90) consecutive calendar days upon receipt of a purchase order and inclusive of the building permit process and material lead-time;
 - c. Submission of a conceptual design illustrating the size and design of the awning.
 - d. Submission of Bid (with required documents): one original and two complete copies; and
 - e. Cost breakdown for:

1. Building 900 Awning Bid Price Sheet:

Description of Work	Cost for Supplies, Materials, etc..	Cost for Labor	Total
a. Removal and disposal of the existing awning. (i.e. Corrugated roof sheet panels, purlins, rafters, etc...)		\$10,355.39	\$10,355.39
b. Removal and disposal of the existing metal columns and beams		\$4,002.08	\$4,002.08
c. Installation of new metal columns and beams (Option 1 for Black Iron and Option 2 for Galvanized)	\$70,087.18 Opt1 \$53,760.79 Opt2	\$18,369.81 \$18,369.81	\$88,456.99 \$72,130.59
d. Installation of cable bracing at three (3) specific locations	\$3,751.95	\$1,500.78	\$5,252.74
e. Installation of new Purlins, S-layer and 2'-6" overlap including all component elements	\$8,754.56	\$3,501.82	\$12,256.38
f. Installation of new rafter system including all component elements	\$16,456.27	\$1,645.63	\$18,101.89



**GCC Bid No:
GCC-FB-21-009**

**Bid Description:
Replacement of Building 900
Metal Awning Structure**

May 2021

Page 4 of 7

g. Installation of 22 gauge thickness corrugated roof sheet panels to include roof sealant for fastener and joint protection and leak prevention.	\$22,511.72	\$9,004.69	\$31,516.41
h. Application of oil based primer and two (2) coats final paint on corrugated roof sheet panels (top and bottom)	\$5,402.81	\$2,161.13	\$7,563.94
i. Removal and reinstallation of additional tools, equipment, infrastructure, etc... into the new awning structure.		\$2,084.42	\$2,084.42
Total Project Bid Price	Option 1: Black Iron Option 2: Galvanized Iron		\$179,590.24 \$163,263.84

- e. Submit ALL required documents (A. General Requirements of the Scope of Work (SOW) and B. Technical Specifications of the SOW), before **June 03, 2021** to:

Joleen Evangelista, Procurement & Inventory Administrator
Materials Management Office
Guam Community College
One Sesame Street
Student Services and Administration Building, Room 2105
Mangilao, Guam 96913

18. GCC shall be indemnified for any under-estimations / oversights attributed to the Qualified Contractor's lack of due diligence or wrongful assumptions.

B. Technical Specifications:

1. Awning: The new awning design shall be identical to the existing awning system at building 900.
 - a. Removal and disposal of existing metal awning to include sheet panels, purlins, rafters and all component elements;
 - b. Removal and disposal of existing metal columns and beams;
 - c. Installation of new metal columns and beams with oil-based primer and two (2) coat final paint;
 - d. Installation of cable bracing at 3 specific locations;
 - e. Installation of purlins S-layer and 2'-6" overlap;
 - f. Installation of rafter system;
 - g. Installation of 22-gauge thickness corrugated roof sheet panels
 - h. Installation of gutter and downspout.
 - i. Removal and reinstallation of additional tools, equipment, infrastructure, etc... that were a part of the original awning structure (to be determined by Program Deans, Department Chairs and Faculty);
2. The Qualified Contractor shall ensure the new awning structure shall be properly and securely integrated into the building 900 structure;



GCC Bid No:
GCC-FB-21-009

Bid Description:
Replacement of Building 900
Metal Awning Structure

May 2021

Page 5 of 7

3. The Qualified Contractor shall ensure the use of only anti-corrosive fasteners, nuts, bolts, etc... and no metal to metal corrosion reactions as a result of two different metals being in contact;
4. The Qualified contractor shall ensure absolutely no leaks at any point of the new awning structure roof;
5. The Qualified Contractor shall ensure the structure is engineered to withstand maximum sustained winds of 200 miles-per hour.
6. Refer to the attached Exhibit #1

[GUAM COMMUNITY COLLEGE-BUILDING 900 METAL AWING]

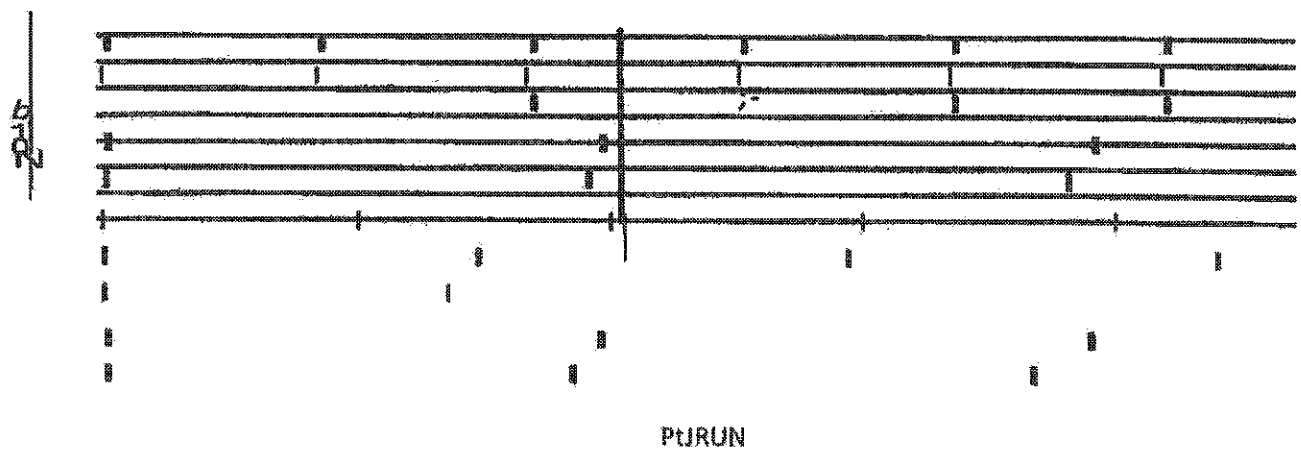
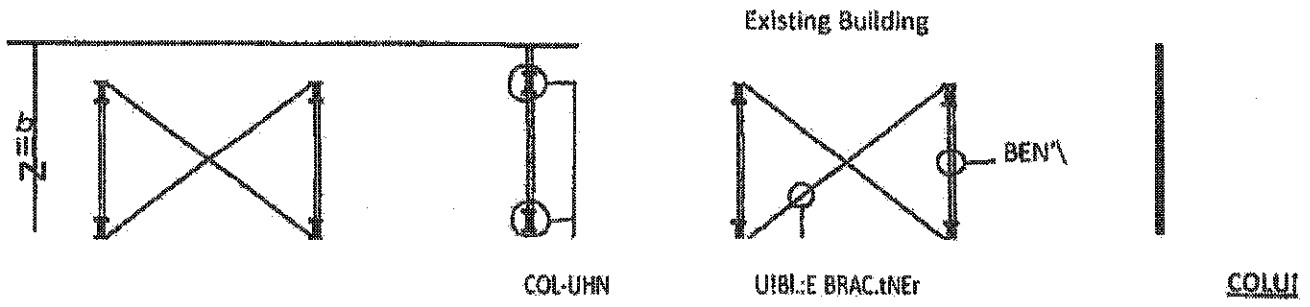
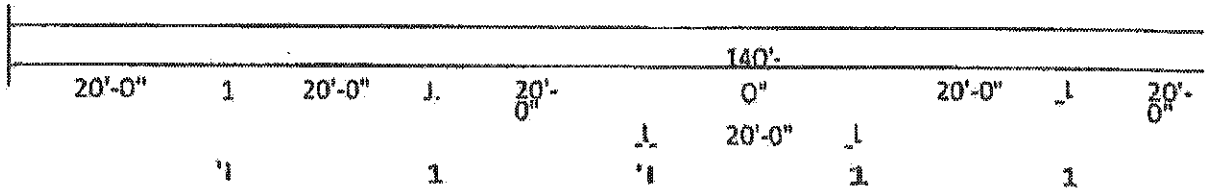

ROOF PURLIN PLAN





GENERAL CAPABILITY STATEMENT

INTRODUCTION

J.J. Global Services dba JJ International Service or JJ Janitorial Service is a small business domiciled in Guam specializing in providing procurement, logistics, construction, facilities maintenance and repairs, and janitorial services to the Federal Government, the Government of Guam, and commercial and residential entities. JJG has qualified staff and an exemplary record.

CORE COMPETENCIES

- a. In the area of Custodial and Janitorial Services, J.J. Global Services has a strong reputation of being one of Guam's leaders in Building Maintenance and Floor & Window Cleaning. The division provides a wide range of custodial services. Our exposure to many clients over the years has given us the experience in cleaning many different flooring materials including Terra Cotta, Granite, Saltillo, Cataluña, Vinyl, and Marble. No material is too tough for us to handle. If we are faced with a new material to clean and maintain, we ensure that we follow the cleaning recommendations as specified by the manufacturer of the flooring material. J.J. Global employs experts in both daily maintenance and in the more specialized services such as carpet cleaning, stripping, sealing and waxing of tiles and marble.
 - b. Daily Housekeeping and Custodial Services are guaranteed performance and covered by a daily checklist for each job site signed by the cleaning supervisor for the site and the customer's representative. All scope of work is based on client's request and our recommendations to ensure cleanliness for each site.
- c. We do carpet steam cleaning with a new latest technology on hand expert carpet specialist personnel. We do special cleaning on kitchens, hoods, oven equipment, and other kitchen appliances. We also do carpet cleaning and furniture cleaning. We have regular maid service for our residential houses, which we provide in 24-hour notice.
- d. Grounds and Facilities Maintenance and Repairs – J.J. Global Services offers grounds, facilities maintenance and repair services to include but are not limited to custodial services, landscaping, tree trimming and grounds maintenance, pruning, herbicidal, plumbing, heating, and air-conditioning, lighting, and preventative maintenance and repairs on pre-existing equipment for our customers.
- e. Construction – J.J. Global Service is licensed as a general contractor in the Territory of Guam with its capabilities ranging from general construction to specialties that include but are not limited to flooring, roofing, carpentry, fencing, irrigational systems, electrical, and installation.
- f. Logistics – Since 1995, J.J. Global Services has offered moving and courier/messenger services to the public.
- g. Procurement – In addition to its services, J.J. Global Service offers its customers superior quality products. J.J. Global is equipped to wholesale and supply lighting fixtures, steam and air-conditioning, and larger merchandise and janitorial supplies.

FINANCIAL CAPACITY

J.J. GLOBAL SERVICES (JJG), an 8A Company, has been in business for over 25 years. JJG has developed good credit standing with the banks and

Physical Address: 215 Rojas Street, Suite 126 Harmon Industrial Park, Tamuning Guam, 96913 Mailing Address: PO Box 217881,
GMF Barrigada Guam 96921
Tel: (671) 632-1179 Fax: (671) 632-3550
Email: jjg@teleguam.net



JJG Global

Facilities Maintenance • Logistics • Construction

vendors is had dealings with. Additionally, JJG had maintained a \$3M per project bonding capability for the past 20 years. We have also acquired various vehicles and equipment needed in accomplishing custodial services contracts. The owner, Mr. Luis E. Bustamante has also a good credit rating and is able to acquire additional equipment needed to perform this project. Currently, JJG can obtain credit up to \$1M from local banks to finance requirements for payroll and supplies before it collects any billing for this project. Through its years of operations, JJG has never defaulted on any project due to financial difficulty and has always completed contracts it has been awarded. Furthermore, JJG has held multi-million-dollar contracts with government entities and understands the processes associated with billing & payment.

COMPLY WITH PERFORMANCE SCHEDULE

JJG can comply with the requirements and delivery proposed in this bid. We will be working closely with the incumbent contractors when sourcing local equipment and staff.

EQUIPMENT LIST

JJG has the necessary vehicles and equipment and/or ability to obtain to fulfill the contract and will produce detailed information as required by the solicitation.

MANAGEMENT PLAN

Introduction: Our firm's mission is to provide a clean comfortable environment for both staff and visitors. Our firm and management are experienced with more than half a century working in the custodial and building maintenance field on government properties. Comfortable facility custodial services have been provided to a wide variety of facilities with as many as eight geographic

areas distances and challenges: airports, government offices, dining facilities, hospitals, school facilities, hotels and military housing change of occupancy. In all cases, our firm has provided professional cleaning services for our customers and occupants.

Capabilities of our firm include: Cleaning Sanitizing Restrooms, common areas, admin offices, as well as mold removal, remediation and biological and pathogen clean up. Our experience includes medical facility housekeeping, outside area pressure washing, medical waste handling and disposal, sanitizing high chairs, cribs, playpens, food service areas, removing trash, vacuuming, spot clean carpet, sweeping, mopping floors, buffing floors, dusting surfaces, washing walls, cleaning upholstered furniture, and any related work as directed by the contracting officer. We have team members with all this experience. Our methodology for cleaning these areas to prevent spread of germs, virus, and bacteria as well as mold will be to use hospital methods of control and chemical solution for sanitizing surfaces in all areas of cleaning. Example: we will use a Flat Mop three bucket system for all floors, Rest Room Tools and equipment will be color coded to limit use only to Rest Rooms. Single use wiping system prevents spreading contamination to clean areas. Uniforms and face mask and gloves, shoe wear help prevent spread or introduction of outside virus and germs. Employees will be monitored each day to detect fevers, cough, or sickness. Employees having positive signs of sickness will not be allowed to work until their symptoms are gone or a doctor has certified them to work.

Green Building Service: Our Green Cleaning Policy is distinct and separate from our Environmental Policy/Environmental Management System. Our Green Cleaning Policy is integral to all parts of our

Shop Address: 351 Alageta Street, Dededo Guam 96929
Office Address: 185 Ilipog Drive, Bldg A Suite 203 Harmon Business Center, Tamuning Guam, 96913
Mailing Address: PO Box 217881, GMF Barrigada Guam 96921
Tel: (671) 632-1179 Fax: (671) 632-3550
Email: jjg@teleguam.net

GCC PR0147



JJGlobal

Facilities Maintenance • Logistics • Construction

standard operating procedures addressing how practices will be utilized, managed, and evaluated. Our Firm will incorporate measurement tools, feedback cycle, and continuous improvement plan requirements set forth to evaluate the effectiveness of green cleaning technologies, procedures, and processes. Green Building Cleaning Industry Management Standards will be incorporated in every phase and implementation of our Management and Planning for executing our Custodial Services Contract at GPA.

Objectives: Our Firm has based our bid offer and staffing on the Technical Exhibits listing type of building, occupants, square footage, and special security considerations, identified tasks, and frequency minimum cleaning standards.

Equipment Cleaning: Power equipment which is Green Building environmental sound are on our equipment list. Vacuums will be certified by the carpet and Rug Institute's, CRI Seal of Approval/Green Label Vacuum program. Vacuums Gold Rated by Rug and Carpet Institute IAW 5.2.7 operate at sound level of 70 DBA or less. Buffers, Shampoo Equipment Scrubbers will all comply with Green Building ISSA standards as much as is possible with availability.

Project Management: Our firm has a seasoned and qualified Project Manager who will be assigned this contract and who possesses experience and successful management of contracts of similar size and scope. The person assigned to serve as our Project Manager and manage this important contract will hold our trust to in applying our established code of conduct and bring to full performance the requirements of the statement of work. Requirements are: US Citizen, speak and write English, experience managing comparable size and scope of contracts for custodial and

building maintenance. This individual will work independently with guidance from our organization, operation manuals, government regulations, and have high ethical and moral standards of personal conduct.

Schedules and Reports:

1. If requested, JJ Global will provide the COR a schedule, no later than five (5) workdays prior to commencing work, showing tasks to be performed by building and identifying a 15-minute time window within which service is to be started and completed at each specific building/floor.

JJ Global will notify the COR of any delay in completing service to any area no later than one hour after an issue arises.

2. **Scheduled Cleaning Work Reports:** JJ Global will provide a monthly spreadsheet detailing the scheduled cleaning work performed in accordance with the contract.

Contingencies: Changes in work schedule to accommodate emergency Interruptions will be quick to resolve and once the problem has resolution with longer days, hours and even weekend work we will return to the normal cleaning schedule at the earliest opportunity. Having a replacement plan handy with recent applications or qualified personnel.

Emergency, and One-time cleaning to areas as designated by the COR as approved. Our firm understands the COR will request us to make a site visit of the proposed area to receive service and a price proposal will be submitted for approval immediately. Our Firm will deliver our cost proposal within one hour.

Emergency Cleaning Response: Our firm upon notification will respond and start emergency work

Shop Address: 351 Alageta Street, Dededo Guam 96929
Office Address: 185 Ilipog Drive, Bldg A Suite 203 Harmon Business Center, Tamuning Guam, 96913
Mailing Address: PO Box 217881, GMF Barrigada Guam 96921
Tel: (671) 632-1179 Fax: (671) 632-3550
Email: jjg@teleguam.net

GCC PR0148



JJ Global

Facilities Maintenance • Logistics • Construction

within 2 hours of notification. We will maintain a GO Team of an on-call list of employees that have been vetted for clearance and live-in proximity to the project location to be called in for any emergency work request. Our Firm will maintain GO kits appropriate to most emergency calls, so we can arrive timely and ready to work to resolve the issue quickly. Our firm understands that pricing will be negotiated on a case-by-case basis with vendor. GO kits include spill kits, wet dry vacs, carpet shampoo unit, squeegee, mops, buckets, warning signs, parking cones, boots, gloves, eye protection, and vehicles for transport. Our Firm is well experienced with emergency response and we will be well prepared to respond with adequate numbers of personnel, equipment, tools, security to various emergency conditions. We have performed contracts in the Pacific Region on similar custodial contracts in Typhoon conditions and the aftermath and understand that preparation and planning is the only way to be successful.

Supplies: We have included the cost of providing all supplies to include in accordance with the solicitation: Toilet Tissue Paper, Toilet Seat covers, liquid soap, paper towels, trash can liners in multiple sizes as appropriate, cleaning chemicals, cleaning supplies, disposable wipes.

Work-Flow: This custodial contract has been arrived at from careful consideration of all requirements of the government statement of work and frequency and type. Our President has years of experience in this type of work and applied his considerable experience in the custodial maintenance field to arrive at a logistical management approach to making this a successful contract for our customer.

Employees reporting to work will be screened for health issues, no coughing, temperature, fever,

chills. Employees must always wear their company uniform as well as their security badge and ID's. The supervisor will issue supplies for cleaning, tools, equipment needed, written instructions for special items, and QC reports as feedback from inspections. Spare uniforms for replacement as needed to keep custodians all looking professional will be readily available as well as gloves, safety glasses, aprons, shoe covers, floor safety hazard warning signs.

Modern ISSA Green Building Technology and cleaning techniques: This is a hallmark of JJ Global, incorporating advanced technology and improved techniques for cleaning and maintaining facilities to the highest of custodial standards maximizing the productivity of our workforce. We plan to use the best and most current methods for building custodial service to the safety of our customers without being intrusive on their work.

Examples of this are:

- Use of equipment like our Karcher KM 105/110 R Bp Pack Riding Vacuum/Sweeper with hydraulic container lift. The sweeping crescent side brush enables corner cleaning in a single pass. Cleans in a single pass, unlike other machines which need 5 to 7 passes - and sweeping by hand is not necessary. The Teach system automatically adjusts the main sweeper roller to wear and tear for consistently outstanding sweeping results. A further feature is the patented, fully automatic Tact filter cleaning system for dust-free operation. Bottom line is faster & more equipment means less manpower.

Use of the Windsor Chariot iExtract Stand up Riding Carpet Cleaner which is engineered for deep restorative extraction for carpets with heavy accumulation of soil and stains. This unit has cylindrical brushes which sweep small debris into a

Shop Address: 351 Alageta Street, Dededo Guam 96929

Office Address: 185 Ilipog Drive, Bldg A Suite 203 Harmon Business Center, Tamuning Guam, 96913

Mailing Address: PO Box 217881, GMF Barrigada Guam 96921

Tel: (671) 632-1179 Fax: (671) 632-3550

Email: jjg@teleguam.net

GCC PR0149



JJGlobal

Facilities Maintenance • Logistics • Construction

debris bin and aggressively attack and remove soil and stains. The Chariot family of cleaning equipment:

- Use of the Micro-fiber Flat Mop system which allows custodian to mop an area using less water, safer (Non-Slip) environment for occupied areas with foot traffic, less exerted strength, more effective cleaning of the floor and healthier environment and less waste. Floors are left in a more pristine condition with appealing shine. Here is a link to video to see how it works:
<https://www.youtube.com/watch?v=acdIGoHONEA>
- Use of Dry Stripping (Square Scrub) system is the newest technology on the market capable of stripping up to five layers of floor coatings by a single employee increasing productivity. This technology also allows for a safer working environment allowing no use of chemicals and maintaining dry surfaces to prevent slip and fall accidents. Here is a YouTube link to a video of the equipment and method in actions:
<https://www.youtube.com/watch?v=9KiDz18e8X4>
- Use of Wide Area Vacuuming: These vacuums allows to cover large open carpeted areas to maximize productivity. Please see link below for video presentation.
<https://www.youtube.com/watch?v=caGEf8pOVNM>
- Use of Micro-Fiber Dusting which is the latest technology on the market minimizing the use of chemicals and avoiding the spread of dust. This technology has a versatile want allowing access of hard to reach areas and has a high durability. Please see link below for video presentation.
<https://www.youtube.com/watch?v=uAgEdczRcV5>

STAFFING PLAN

DEVELOPMENT OF CREWS:

Staffing Methodology. Our staffing plan was determined based on RS Means book representing national standards for facilities staffing based on productivity rates per square foot. In addition, JJ Global Services has adjusted the RS Means rates which has been tailored to local productivity rates per square foot or based on the specific requirements of the Statement of Work. We have arrived at staffing based on the number of areas to be serviced each day, the size of the square footage to be cleaned, type of service, restrooms, administrative and types of customers. All these things are considered in deciding the number of man hours and number of people to clean and service the GPA areas. Quality Control staff is determined based on many of these same factors and the number of personnel working at any given time of day. New employees will receive orientation and training before starting work and will be accompanied by a trainer and custodian. Inspection and training are of paramount importance to quality of service. We can learn as much from our custodians and they can learn from our management team with innovation and quality equipment and materials. Our goal is the same "Quality Service providing a healthy environment for our Customers."

STAFFING PLAN

Selection: All applicants will complete a Job Application for our company that provides for their experience performing the type of work position they are applying for. Applicants will undergo a background criminal history check. Our recruiter will measure their credentials and experience

Shop Address: 351 Alageta Street, Dededo Guam 96929
Office Address: 185 Ilipog Drive, Bldg A Suite 203 Harmon Business Center, Tamuning Guam, 96913
Mailing Address: PO Box 217881, GMF Barrigada Guam 96921
Tel: (671) 632-1179 Fax: (671) 632-3550
Email: jjg@teleguam.net

GCC PR0150



JJ Global

Facilities Maintenance • Logistics • Construction

against our established Job Description Category for a best match.

Retention: JJ Global has an outstanding record of retention of our employees on all our contracts. This retention of quality trained experienced employees is critical to sustained quality performance. Every phase of our management strategy is to acknowledge and retain quality employees performing quality work. This is accomplished by awarding employees for performing their jobs and for going the extra mile for the customer. Employee of the Month, Most improved employee of the month. Award for innovation, Award for attendance, Birthday and personal achievements, graduation or attending advanced education or training. Our Company provides: fringe benefits of Holiday Pay, Personal paid days off, Paid Family Leave, paid Vacation Days, Seniority, Health and Welfare benefits, Insurance.

Training: JJ Global provides on the job training and classroom training with ISSA CMIS training videos, videos and vendor training programs. Training includes paid training sessions and mentor protégé training. Safety training, medical response training, restroom cleaning and sanitizing and cross contamination control steps.

Support: The support of our contract and all our personnel comes from corporate services, payroll, time keeping, code of conduct, record keeping, health insurance, workers compensation insurance, uniforms, tools, equipment, safety personal protection, training in both their job and to advance to the next level or prepare for a better job.

Replacement: Replacement is handled much the same as any job filling, by our Director of Operations who looks within the organization for replacement candidates and then to our recruitment program

with the local Guam Job Service. Qualifications for experience and training and Key Position Personnel (Project Manager) particularly have certain prequalifying factors.

Project Manager – a full time position performing 2080 hours per year. Experience includes 3 years of experience in the management of contracts of similar scope, size and geographic scope.

Quality Control/Safety Manager – a full time position performing 2080 hours per year. Experience includes 3 years of experience of Quality Control & SSHO or managing contract work similar in scope.

Crew Supervisor – a full time position performing 2080 hours per year. Experience include 3 years of experience in the operations managing and supervising multiple crews, personnel, tasks and scope of work.

Janitors/Carpet Cleaners/Water-Blasters – full and part time positions, flexible hours, experience is helpful but with participation in our training program, they will find success. Must have the ability to understand the required scope of work and task schedules.

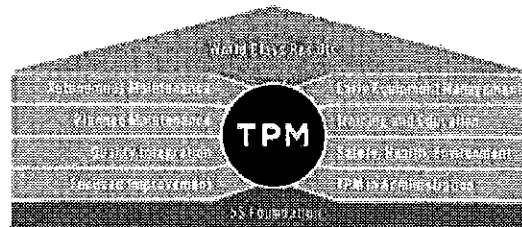

Integrity and Business Ethics

JJ Global has vast experience in providing an array of construction, janitorial, landscaping, and

Shop Address: 351 Alageta Street, Dededo Guam 96929
Office Address: 185 Ilipog Drive, Bldg A Suite 203 Harmon Business Center, Tamuning Guam, 96913
Mailing Address: PO Box 217881, GMF Barrigada Guam 96921
Tel: (671) 632-1179 Fax: (671) 632-3550
Email: jjg@teleguam.net



JJGlobal

Facilities Maintenance • Logistics • Construction

housekeeping services for private corporations and federal entities. The key to our growth is in the quality of employee performance. We make it our business to ensure that we attend to their welfare, making them feel as part of a family, the *JJ Global family*.

Firm expects the same professional relationship on this important contract. Good communication on a frequent basis with our government team partners prevents misunderstandings and resolves issues quickly and transparent.

Our objective is to provide our clients with personal services tailored to their specific needs at reasonable rates and more importantly, obtain "Customer Satisfaction". We perform on the premise of "working smarter, not harder" by providing professional training to our employees on the latest products available and the use of equipment, conducting safety meetings, and continuously seeking advanced technologically, efficient and earth-friendly cleaning, maintenance and construction equipment, to perform resourcefully to meet our client's needs. JJG has been in operations for 27 years, and currently has more than 100 permanent employees on staff and as many as 150-300 workers on site depending on what the project entails. On average, we annually have approximately 50-100 employees on staff. JJG has grown since we were founded in 1995, and have advanced from smaller accounts to larger accounts, including stores, hotels, malls, airport, to Naval Base and Anderson Air Force Base contract including heavy equipment rental and construction services. The robust management structure implemented for this project promotes an organizational culture that encourages ethical conduct and a commitment to compliance with the law and submits entirely to the 52.203-13 Contractor Code of Business Ethics and Conduct.

Business Relations

Our Firm and management have excellent record of business relations with government contract officials and vendors that support our efforts. Our

Shop Address: 351 Alageta Street, Dededo Guam 96929

Office Address: 185 Iipog Drive, Bldg A Suite 203 Harmon Business Center, Tamuning Guam, 96913

Mailing Address: PO Box 217881, GMF Barrigada Guam 96921

Tel: (671) 632-1179 Fax: (671) 632-3550

Email: jjg@teleguam.net



JJGlobal

Facilities Maintenance • Logistics • Construction

STATEMENT REGARDING QUALITY CONTROL

QUALITY CONTROL

Our Firm has an established Quality Control System (QC) centered on a whole Management, Quality approach to managing and operating the contract approach that has been successfully implemented on our previous government contracts. The Quality Control consists of the plans, procedures, and organizational structure necessary to produce an end-product that complies with the Performance Work Standards and requirements of this specific government contract. Our Quality Control Program procedures will identify performance short comings, problems, make corrections, prevent defective work and ensure non-reoccurrence of deficiencies.

Quality Control Plan: JJ Global Quality Control Plan is an integral part of our project management. We will appoint a dedicated Quality Control Manager with no other duties than Quality Control, who will oversee the implementation and documentation of this plan. Quality Control Manager will report to the company Director of Operations directly and provide daily reports to our project manager and make recommendations on corrective actions. Each line item of the contract will be evaluated against the standards of performance laid out in the government contract requirements. QC Inspections will document performance against the government contract Performance Work Statement of Requirements standard with recommendations on how to correct performance before it becomes

unacceptable. Inspections of routine daily work will be random basis. Work performed less often than daily will be inspected on a scheduled basis. Monthly work and less often will be inspected 100% on scheduled basis. Frequency of inspection will change depending on inspection findings that indicate a problem or indicate performance shows less need for frequency of inspection. QC Program will include the inspection of Submittals to the government regarding accuracy, timeliness.

Policy & Objectives of QC Plan: Our Firm has developed and implemented Quality Control on similar requirement and scope custodial contracts for government agencies. Our Firm will customize a Quality Control Plan specific to this contract and all performance work requirements. The QC Plan provides for continual improvement, and integration into the overall Management system. A copy of this specific QC Plan for this contract will be presented to the Contracting Officer and COR ten (10) days prior to start of contract if so requested.

Identify Procedures to Prevent and Ensure deficiencies are promptly noted, and re-performance is made. Cause of defect is determined, and action taken at each level in the operation to ensure going forward that the same mistake is not repeated. This correction may require re-training, change in technique, change in materials, or change in personnel as determined by management. Tracking of defects or near defects is important to the Quality Control Management program. Inspection reports will be kept on file and available for Government review upon request. Inspections Quality Control begin with the Janitor performing the work by completing a self-check list inspection of work on the schedule for that building that date. A copy is posted in the Restroom and initialed by Janitor and inspected by Crew Leader of work performed under their control crew. Crew Leader also signs the check list inspection and fills

Shop Address: 351 Atageta Street, Dededo Guam 96929

Office Address: 185 Ilipog Drive, Bldg A Suite 203 Harmon Business Center, Tamuning Guam, 96913

Mailing Address: PO Box 217881, GMF Barrigada Guam 96921

Tel: (671) 632-1179 Fax: (671) 632-3550

Email: jjg@teleguam.net

GCC PR0153



JJGlobal

Facilities Maintenance • Logistics • Construction

out their own inspection form. Supervisor performs inspections of work and completes an Inspection form with list of work performed on the schedule. Quality Control Manager makes their own inspection of buildings on either a random or scheduled basis to verify work and does an inspection of work performed and verifies the self-inspection check list of the Janitor, crew leader, supervisor. Inspections and Reports are tracked and used to make a performance report for the management. Record is kept on file and is made into report for the COR.

Shop Address: 351 Alageta Street, Dededo Guam 96929
Office Address: 185 Ilipog Drive, Bldg A Suite 203 Harmon Business Center, Tamuning Guam, 96913
Mailing Address: PO Box 21788 J, GMF Barrigada Guam 96921
Tel: (671) 632-1179 Fax: (671) 632-3550
Email: jjg@teleguam.net

GCC PR0154



JJGlobal

Facilities Maintenance • Logistics • Construction

STATEMENT REGARDING SAFETY PROGRAM

SAFETY AND ACCIDENT PREVENTION

Our Firm takes all Safety training and practices seriously. A Training Manager will be designated to oversee and manage the day to day incorporation of sound safety practices and training. Our Management plan incorporates as a key element the training of all employees at every level in the safe practices of each task. This includes proper use of Personal Protection Equipment (PPE) attire for work, shoes, gloves, eye protection, hearing protection, safe use of elevated work, use of ladders, keeping walkways, passageways, sidewalks free of equipment

JJG has a safety philosophy developed to reflect and communicate the proactive safety attitude maintained throughout our organization. The PM/SSHO and Supervisor/QC will have authority over all employees on the project. Our commitment is 100% team effort on all aspects of this project.

Our goal is to maintain an environment where safety is a team effort with each person looking out for each other. To ensure safe work, the PM/SSHO will promote safety and conduct weekly safety tailgate meetings. Our team will comply with appropriate safety and security laws and regulations such as those established by the EM 385-1-1, OSHA, EPA, DOT and all other applicable federal, state, and local safety and health regulations. In addition to complying with company policies and procedures, our client's safety and health rules and regulations will also be strictly enforced. The safety and health of all employees is of utmost

importance, along with quality of work performed, meeting customer expectations and cost control. JJG's greatest asset is its employees and we are committed to providing a safe and healthy work environment.

JJG fully understands that the diverse nature and complexity of the safety program requires that safety be given the highest priority when executing any work. JJG is fully prepared to ensure that the organizational structure of the Safety Program supports clear communications and standardizations across all facets of the work scope. Towards this effort, JJG has adopted a 4 Point Safety Management System Illustrated below:

1. Safety Education and Awareness. We recognize that having trained and qualified personnel is integral to achieving high safety performance on each of our job sites. As such, Safety Education (Training) and Awareness is a key component of JJG's safety management system. All employees will be required to attend weekly safety briefings before starting each work week. These "huddles" will be designed to encourage workplace safety and peer to peer accountability for implementing safe practices.

2. Workplace Inspections and Audits. In order to ensure safe practices are being performed, daily and routine inspections (both random and scheduled) will be conducted at each facility. These inspections will be designed to identify workplace hazards and to develop mitigation plans and to take correction action as needed to prevent mishaps. All staff (employed directly by JJG or as a subcontractor) will be subject to these inspections. Audits will be conducted which will also confirm that safety practices are being performed regularly and reports will be submitted to management as well as the Safety Council. JJG understands that it is vitally important to "inspect what we expect". If we

Shop Address: 351 Alageta Street, Dededo Guam 96929
Office Address: 185 Ilipog Drive, Bldg A Suite 203 Harmon Business Center, Tamuning Guam, 96913
Mailing Address: PO Box 217881, GMF Barrigada Guam 96921
Tel: (671) 632-1179 Fax: (671) 632-3550
Email: jjg@teleguam.net

GCC PR0155



JJGlobal

Facilities Maintenance • Logistics • Construction

expect to deliver superior safety performance, we must be diligent in inspecting facilities and monitoring employee safety practices on a regular basis. JJG is committed to this process and will be a large part of the QM/Safety Officer's responsibility.

3. Rewards and Recognition. Engaging employees to take responsibility for safe practices is also a key element of JJG's safety management system. Employees will be recognized and rewarded for exceptional safety practices. Employees will be recognized monthly for the safety performance and team incentives will also be established to encourage all employees to look out for one another. These incentives will include free lunches, dinners, movie tickets, cash bonuses, as well as certificates of achievement for consistent safe practices.

4. Technology Solutions. Technology are important tools to ensure safe practices. JJG is committed to implement systems that take advantage of technological advances, equipment that improves the safety of employees. Technology will also be utilized in reporting risk hazards on a timely basis via iPad/laptop and will offer real time response and be utilized to monitor schedules as well as safety records for each job site.

Our QCM/Safety Manager will be primarily responsible for ensuring that the 4- point system is implemented and monitored effectively. The QCM/Safety Manager will evaluate all employees on the project and have the responsibility of safety inspections to ensure all employees maintain and/or exceed the safety guidelines. JJ Global will further ensure effective safety management will facilitate continuous improvement in safety performance by managing hazards, mitigating risks and implementing actions to reduce mishaps through our comprehensive workplace

inspections.

Authorized Negotiator and Signatory on behalf of
JJ Global Services:

Name: Aileen de Dios
Title: General Manager
Tel: (671)632-1179
Fax: (671)632-3550
Email: aileen@jjglobal.services

Shop Address: 351 Alageta Street, Dededo Guam 96929
Office Address: 185 Ilipog Drive, Bldg A Suite 203 Harmon Business Center, Tamuning Guam, 96913
Mailing Address: PO Box 217881, GMF Barrigada Guam 96921
Tel: (671) 632-1179 Fax: (671) 632-3550
Email: jjg@teleguam.net

GCC PR0156



PROJECT NARRATIVE

J.J. Global Services is licensed as a general contractor in the Territory of Guam with its capabilities ranging from general construction to specialties that include but are not limited to flooring, roofing, carpentry, fencing, irrigational systems, electrical, and installation.

For *GCC-FB-21-009 Replacement of Building 900 Metal Awning Structure*, JIG is prepared to follow the Technical Specifications set forth in the IFB with the below methodology:

AWNING STRUCTURE CONSTRUCTION METHODOLOGY

1. Establish the location of the rafter tie in and drill the rafter connecting holes in the existing building column flanges.
2. Place supports on the foundation under the base plates directly below where the column flanges will be.
3. All the supports need to be shot to elevation so that when the columns are set, they are level and at the proper elevation.
4. All column base plates should transform an open space alongside a building with metal grouted after installation to ensure that the entire column base plate is in bearing on the foundation.
5. Erection then can begin by starting in a braced bay by standing up columns and providing temporary bracing for stability until the rafters, bracing, girts and purlins are installed to maintain the frame's geometry.
6. After the structure is being detailed out in the field, the squaring of the structure occurs.
7. In the squaring of the structure, it involves surveying the top of the columns for plumb, installing temporary bracing as required, tightening anchor bolts, and adjusting permanent bracing to maintain the geometry of the structure as designed.
8. Finally, the lean-to is complete by attaching the lean-to rafter to the new column and main building.

Attaching a metal awning with the existing building:

9. A steel truss frame style building will simply use a plate that bolts between back-to-back structural columns, leaving a thin slot to come through the sheeting.
10. Once this connection is made, all the remaining work can be done from the outside of the building.
11. Columns would be fastened to anchor bolts that would be anchored in footings—these can be just small piers.
12. Rafters would be bolted to the tops of the columns.
13. Purlins would be mounted to the rafters perpendicular, and the sheeting would be screwed to the purlins on the roof.
14. Then a few pieces of rake trim, and gutter or eave trim will finish it out.

Physical Address: 215 Rojas Street, Suite 126 Harmon Industrial Park, Tamuning Guam, 96913 Mailing Address: PO Box 217881,
GMF Barrigada Guam 96921
Tel: (671) 632-1179 Fax: (671) 632-3550
Email: jjg@teleguam.net



JJGlobal

Facilities Maintenance • Logistics • Construction

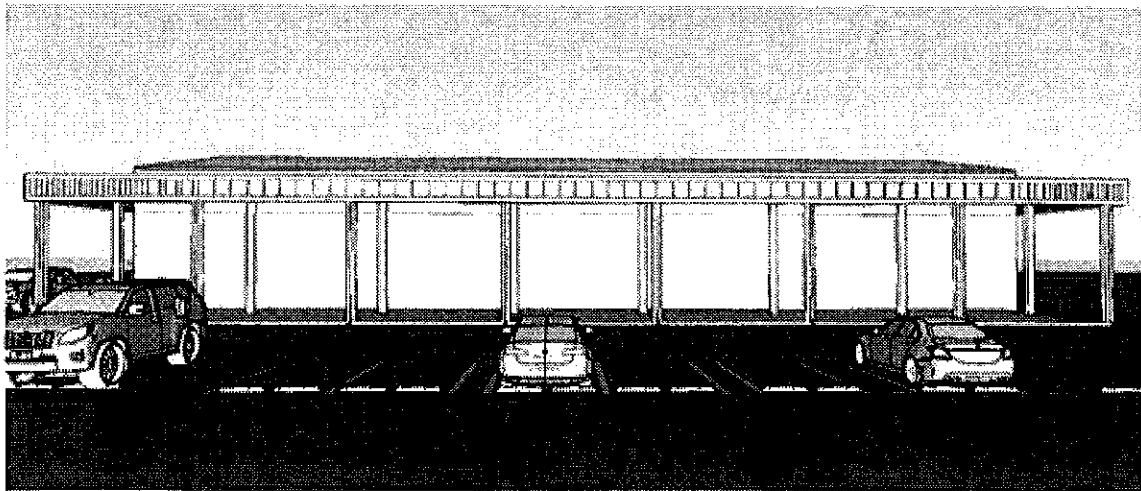
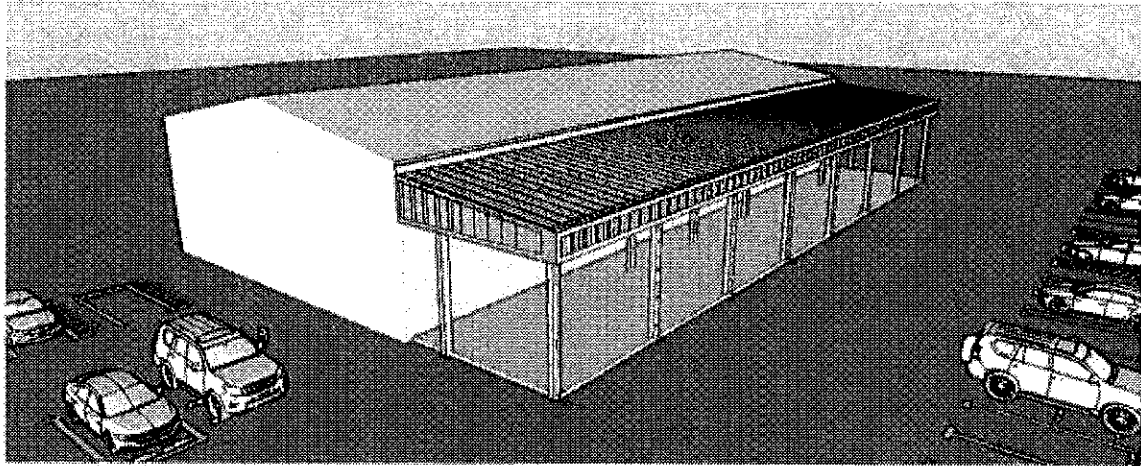

Shop Address: 351 Atageta Street, Dededo Guam 96929
Office Address: 185 Ilipog Drive, Bldg A Suite 203 Harmon Business Center, Tamuning Guam, 96913
Mailing Address: PO Box 217881, GMF Barrigada Guam 96921
Tel: (671) 632-1179 Fax: (671) 632-3550
Email: jjg@teleguam.net



JJGlobal

Facilities Maintenance • Logistics • Construction

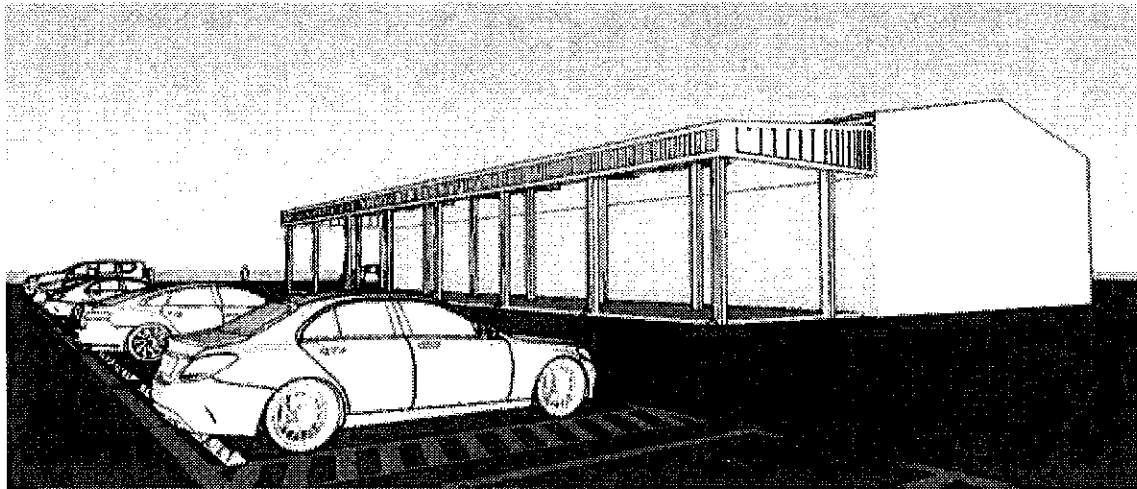
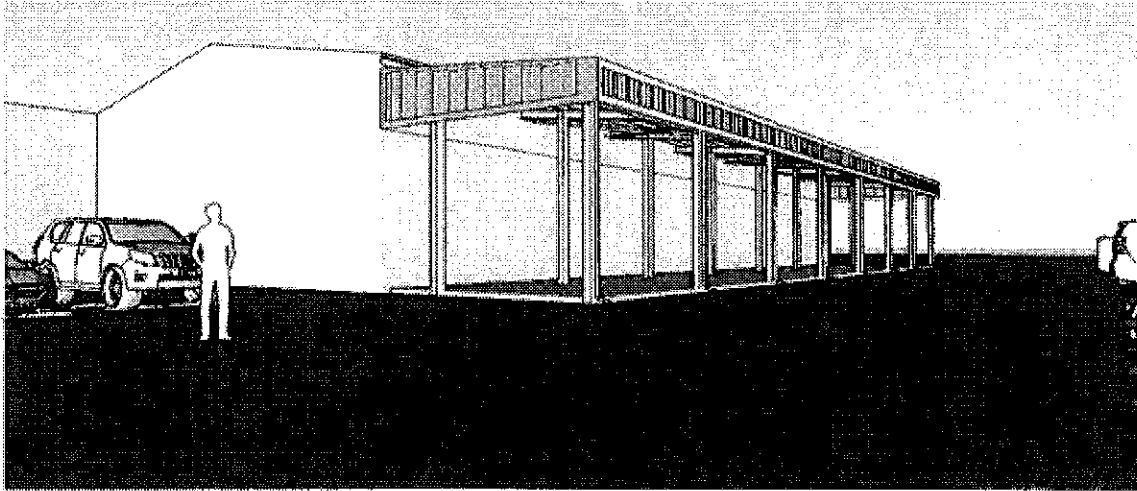

Shop Address: 351 Alageta Street, Dededo Guam 96929
Office Address: 185 Ilipog Drive, Bldg A Suite 203 Harmon Business Center, Tamuning Guam, 96913
Mailing Address: PO Box 217881, GMF Barrigada Guam 96921
Tel: (671) 632-1179 Fax: (671) 632-3550
Email: jig@teleguam.net

GCC PR0164



JJGlobal

Facilities Maintenance • Logistics • Construction

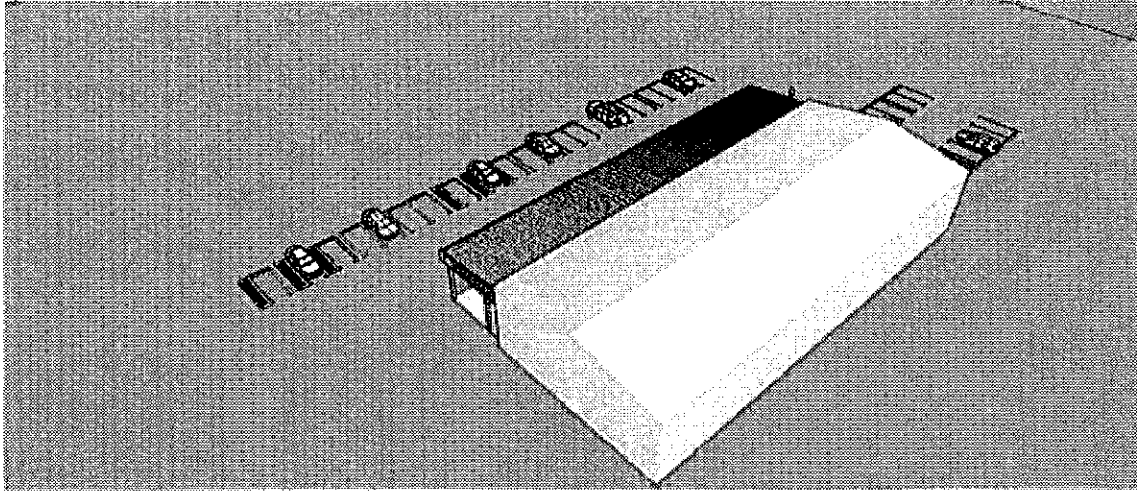

Shop Address: 351 Alageta Street, Dededo Guam 96929
Office Address: 185 Ilipog Drive, Bldg A Suite 203 Harmon Business Center, Tamuning Guam, 96913
Mailing Address: PO Box 217881, GMF Barrigada Guam 96921
Tel: (671) 632-1179 Fax: (671) 632-3550
Email: jjg@teleguam.net

GCC PR0165



CRITICAL PATH METHOD CPM CHART & SCHEDULE

Activity start	Activity end	Activity Description	Normal Time	Earliest Time (TE)		Latest Time (TL)		Total Float
				Start (ES)	Finish (EF)	Start (LS)	Finish (LF)	
1	2	Assessment and evaluation of existing structure	3	0	3	0	3	0
1	3	Design Phase	7	0	7	0	7	0
3	4	Application for Building Permit & other Licenses	14	7	21	7	21	0
4	5	Mobilization	3	21	24	21	24	0
5	6	Removal of existing tools, equipment, etc. from the structure	5	24	29	24	29	0
5	7	Removal and disposal of the existing awning (Phase 1)	4	24	28	24	28	0
7	8	Removal and disposal of the existing metal columns and beams (Phase 1)	10	28	38	28	38	0
7	9	Removal and disposal of the existing awning (Phase 2)	4	28	32	44	48	16
9	10	Removal and disposal of the existing metal columns and beams (Phase 2)	10	32	42	32	42	0
8	9	Installation of new metal columns and beams (Phase 1)	10	38	48	38	48	0
10	11	Installation of new metal columns and beams (Phase 2)	10	42	52	42	52	0
10	12	Installation of new rafter system	7	42	49	42	49	0
12	13	Installation of cable bracing	5	49	54	49	54	0
12	14	Installation of new purlins	7	49	56	49	56	0
14	15	Installation of corrugated roof sheet panels	14	56	70	56	70	0
15	16	Application of oil based primer and paint	5	70	75	70	75	0
14	17	Production and submission of as-built plans	7	56	63	68	75	12
15	17	Re-installation of removed tools, equipment, etc. from the structure	5	70	75	70	75	0
17	18	Demobilization	3	75	78	75	78	0

Table 1. Computation for CPM of Awning Structure

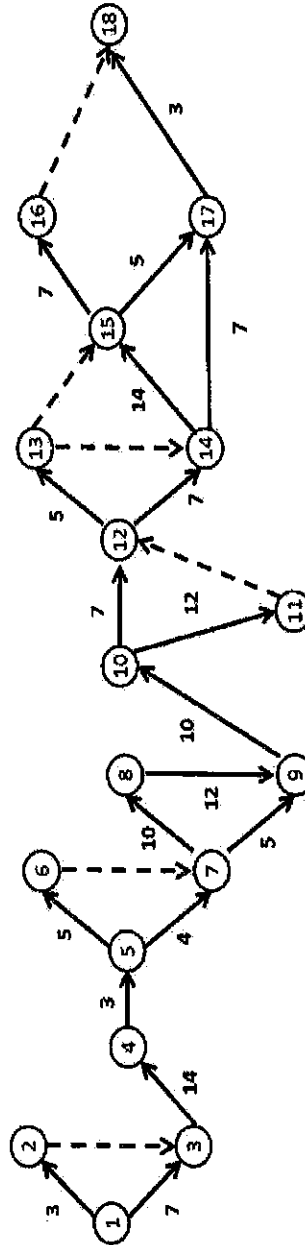
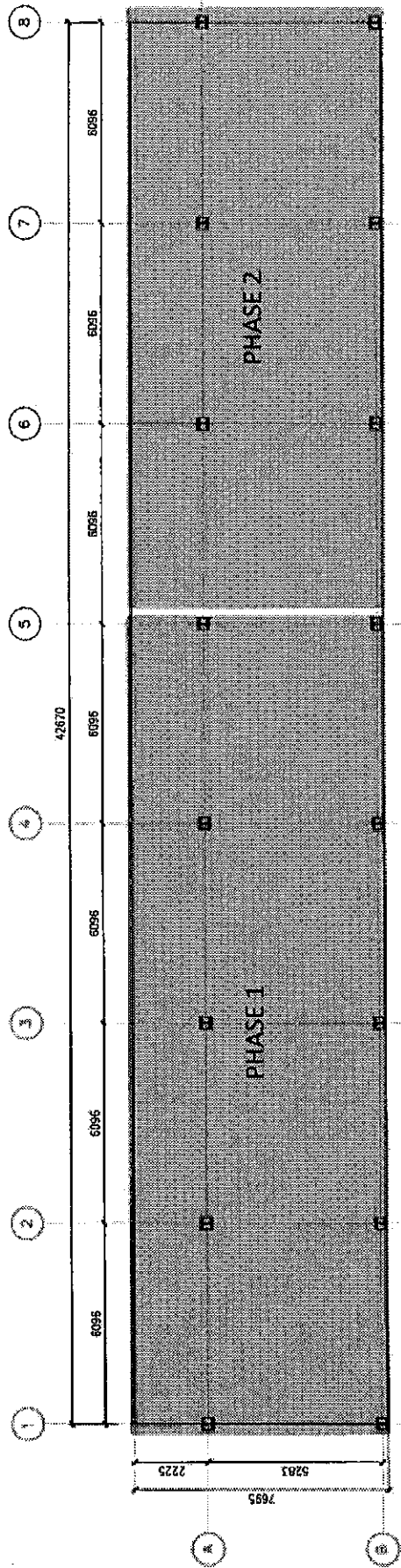

Figure 1. Critical Path Method (CPM) Diagram for Design & Build of Awning Structure



FRAMING PLAN
 SCALE: 1/12" = 1'-0"

5/21/2021

JJ Global International Mail - Fwd: Pre-Bid Conference Minutes



Ambros Mori Rokop Jr. <ambros.rokop@jjglobal.services>

Fwd: Pre-Bid Conference Minutes

1 message

Alleen de Dios <alleen@jjglobal.services>

To: Kim Casin <kim.casin@jjglobal.services>, "Ambros Mori Rokop Jr." <ambros.rokop@jjglobal.services>

----- Forwarded message -----

From: Patricia Palacios <patricia.palacios@guamcc.edu>

Date: Thu, May 20, 2021, 5:52 PM

Subject: Pre-Bid Conference Minutes

To: Claytech Inc <admin@claytechinc.com>, <sales@pelinthesheds.com>, <ee_tbgc@yahoo.com>, Alleen de Dios <alleen@jjglobal.services>, <jerome.uson@jjglobal.services>, <craigbass@jjglobal.services>
Cc: Guam Community College <materialmanagement@guamcc.edu>, Francisco Palacios <francisco.palacios1@guamcc.edu>, Inocencio SanAgustin <inocencio.sanagustin@guamcc.edu>

To All Prospective Bidders,

Attached is the Pre-Bid Conference Minutes for GCC-FB-21-009, Replacement of Building 900 Metal Awning Structure..

Please acknowledge receipt of this email no later than 5:00 pm, Friday, May 21, 2021.

Thank You,

Patricia U. Palacios

Buyer II

Materials Management Office

materialmanagement@guamcc.edu

Tel: 735-5540/5542



Email administered by Guam Community College

Pre-Bid Conference Minutes.pdf
39K

[Handwritten Signature] 5/21/2021

GUAM COMMUNITY COLLEGE

PRE-BID CONFERENCE NOTES

Bid No.: GCC-FB-21-009

Bid Description: Replacement of Building 900 Metal Awning Structure

Attendance:

Guam Community College: Joleen Evangelista (MMO), Patricia Palacios (MMO), Francisco Palacios (P&D), Inocencio San Agustin (P&D)

Vendors:

ClayArch Inc.; Hak Jung Kim, Min Chul Kang, Paradise Awning; Alex Au-Yeaung, Top Builders, LLC; Edwin Aclan, JJ Global Services; Aaron Burger, Jerome Uson, Craig Uson

Meeting called to order by Joleen Evangelista, MMO @ 10:00 a.m. Introductions conducted.

Procurement Requirements: This is the Mandatory Pre-Bid Conference & Site Visit for GCC-FB-21-009-- Prospective Bidders must be in present attendance at the pre-bid conference and pay the \$25.00 fee by 4:00 pm today, in order to qualify for the bid. Prospective bidder must submit an original and two copies of the bid in a sealed envelope and can be submitted prior to 10:00 a.m., Thursday, June 3, 2021. No Late Bids are accepted. Bid Packets must be dated and stamp by Materials Management Office. Any questions asked must be in writing and submitted to materialsmanagement@guamcc.edu no later than Thursday, May 20, 2021, 5:00 p.m. Also, acknowledgement of receipt of the amendment is required via email or fax. If you send the questions by fax please call MMO to ensure we received the questions. Please acknowledge indicating your company name & contact person, address & Amendment number on the email. The deadline for GCC to response to the questions is Tuesday, May 25, 2021 by 5:00pm. Required delivery date is 90 Calendar Days upon receipt of the purchase order/contract to include building permit process and material lead time.

A Bid Guarantee of (15% of bid amount) is required it may be in a form of a Cashier's check, letter of credit, surety bond with the certificate of authority, & power of attorney. Brochures/Descriptive Literature/Technical Specifications, Project Narrative, CPM Chart, Conceptual Design. A performance bond is required for this bid. Affidavit Disclosing Ownership and Commissions; Other Affidavits: Non-Collusion, Gratuities and Kickbacks, Ethical Standards and Contingent Fees, all affidavits must be notarized. U. S. Department of Labor Wage Determination (please see instructions in the form however, GCC provided the wage listing in the Bid Packet that must be submitted with the DOL wage form. Also attached to the bid packet is the Government of Guam Holidays, GCC Campus Map and the 5 Year Academic Calendar. Prospective Bidders must acknowledge pre-bid minutes and any Addendums Issued by the GCC Materials Management Office; Upon bid award the successful bidder must provide a current Guam Business License expiring 2021 or 2022. All documents required in the bid must be submitted. Failure to comply with the requirements will be basis of non-selection/disqualification and rejection of the bid. Testing on the structure was done and came back negative, no asbestos or lead found.

Scope of Work Requirements: Guam Community College (GCC) is soliciting the service of a qualified contractor to replace the dilapidated awning structure located at building 900.

Questions:

1. Does GCC need two prices for Galvanize Steel? – JJ Global Services - Yes, you need a price for Option 1 and Option 2-two separate line items.

- > 5:00 p.m., Thursday, May 20, 2021 - Deadline for Questions
- > 5:00 p.m., Tuesday, May 25, 2021 - Deadline for GCC Response to Questions
- > 10:00 a.m., Thursday, June 3, 2021 - Bid Opening. Bidders may submit packages a day before to avoid rushing. No late bids will be accepted. Bidders are welcome but not a requirement to attend the bid opening; however, your bid packet must be submitted before this time. No late packets will be accepted. Today at 4:00pm is the deadline to purchase a bid packet.

Meeting adjourned: 10:22 a.m.

Transcribed by: Patricia U. Palacios, MMO

19-MAY-2021 10:44:45

Guam Community College
Account Receipt 132020

PAGE 1
TGRRCPT

CASHIER: GDIBANEZ

ORIGINAL

GCC MMO Bid Invitation
PO Box 23069 GMF
Barrigada, GU 96921

ID: B00168840

CODE	TERM	DESCRIPTION	TRAN DATE	CHARGE	PAYMENT
MISC	202110	GCC-FB-21-009	19-MAY-21	\$25.00	
VISA	202110	V2900 AARON BURGER	19-MAY-21		\$25.00
TOTALS				\$25.00	\$25.00

Bank ID: 13
Merchant ID
Term ID: 00

XXXXXXXXXXXX2
VISA

Total: 4

05/19/21

Inv #: 000003

Apprvd: Online

Retrieval Ref. #: 31

CHASE VISA
AID: A000000031010
TSI: F900
TVR: 008000000

Customer

Fler

ENCRYPTED TRAN

GCC PR0170

2021

CONTRACTOR'S LICENSE

LOU LEON GUERRERO
Governor of Guam

JOSH TENORIO
Lt. Governor of Guam

Pursuant to the provisions of Chapter VII Title XI of the Government of Guam and the Rules and Regulations of the Contractors License Board, the Executive Director of Contractors hereby issues this license to:

Luis E. Bustamante
dba: JJ Global Services

To engage in the business or act in the capacity of a contractor in the following classifications

**B,C13,C13A,C27,C33,C37,C42,C49,C55 & C68(Epoxy Coating/Injection,
Generator Maintenance & Installation)**

This license is the property of the Executive Director of Contractors, not transferable, and shall be returned to the Executive Director upon demand when suspended, revoked, or invalidated for any reason. It becomes void if not renewed on or before the expiration date.

Signature of RME
RME #

Signature of LICENSEE
License # 7995

GRT # 96571

Certificate # C-0820-1003

Issued: August 11, 2020

Expires: June 30, 2021

JAMES M. CASALLO
CLB BOARD CHAIRMAN



CECIL "BUDDY" L. ORSINI
EXECUTIVE DIRECTOR

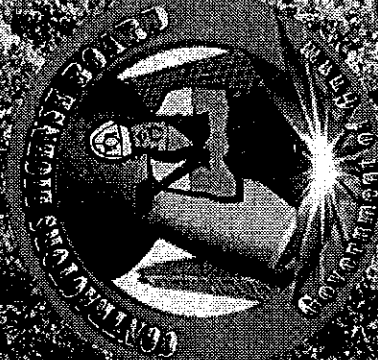

SRL NO: 2113545

BUSINESS LICENSE

DEPARTMENT OF REVENUE AND TAXATION
GOVERNMENT OF GUAM

P.O. Box 23607
Barrigada, Guam 96921
www.guamtax.com

Service

13-00095571-002

ACCOUNT NO.

EXPIRES:

ISSUED TO: LUSTAMANTE, LOIS E.

DOING BUSINESS AS: JO GLOBAL SERVICES

TYPE OF LICENSE: JANITORIAL & LAWN CARE SERVICE

BUSINESS LOCATION: LOT 5284-B Y-LISONG #351 ALAETA ST

DEDEDO GUAM

MAILING ADDRESS: P.O. BOX 217881
BARRIGADA GUAM

662-1175

ZIP: 96921

TELEPHONE: HOME

BUSINESS

7/30/20

FEE	50.00
PENALTY	00
TOTAL FEE	50.00

PAID

JUL 30 2020

Treasurer of Guam

#16

KEEP POSTED IN A CONSPICUOUS PLACE
LICENSE MUST BE PRODUCED UPON
DEMAND TO ANY AUTHORIZED GOVT
OFFICIAL. DO NOT POST COPY.

DAFFE MANSUET-SHIMIZU
John M. Mansuet
DIRECTOR OF REVENUE AND TAXATION

GUAM COMMUNITY COLLEGE
BID INVITATION



Mary A.Y. Okada, Ed.D.
GCC PRESIDENT

GUAM COMMUNITY COLLEGE
P.O. BOX 23069 GMF, GUAM 96921
1 SESAME STR. MANGILAO, GUAM 96913

DATE ISSUED: May 13, 2021 BID INVITATION NO.: GCC-FB-21-009

INSTRUCTION: This BID shall be submitted in original, plus Two (2) copies, in a sealed envelope and delivered to the specified location below on or before (Time) 10:00 A.M., (Date) Thursday, June 03, 2021. The Bid shall be Publicly opened at 10:15 A.M. Bids submitted after the time and date specified above shall be rejected. See attached Solicitation Instructions and Conditions for details.

BID FOR: Replacement of Building 900 Metal Awning Structure
SPECIFICATIONS: See Attached Scope of Work
BID SUBMISSION LOCATION: GUAM COMMUNITY COLLEGE
Materials Management Office
Room 2105 1st fl. Administration Bldg. 2000

Mandatory Pre-Bid Conference & Site Visit 10:00 am., Wednesday, May 19, 2021
GCC Technology Center Building 1000, Room 1107

BID OPENING LOCATION: GCC Technology Center, Building 1000, Room 1107
REQUIRED DELIVERY DATE: 90 Calendar Days upon Receipt of the Purchase Order/Contract

SUBMISSION DEADLINE FOR QUESTIONS: 5:00 P.M., Thursday, May 20, 2021
DEADLINE FOR GCC RESPONSES: 5:00 P.M., Tuesday, May 25, 2021
ALL INQUIRIES REGARDING THIS BID MUST BE ADDRESSED TO: Procurement & Inventory Administrator, Materials Management Office

MATERIALS MANAGEMENT CONTACT INFORMATION: TELEPHONE: 735-5542/5540; FACSIMILE: 734-5238;
EMAIL: materialsmanagement@quamcc.edu; WEBSITE: www.quamcc.edu

NOTE TO BIDDERS:
This bid is subject to the attached General Terms and Conditions of the Invitation for Bids. The undersigned offers and agrees to furnish within the time specified, the articles and services at the price stated opposite otherwise specified by the bidder. The undersigned further agrees this bid will remain firm and irrevocable if accepted within calendar days (60 calendar days unless a different period is inserted), from the date of the opening, to furnish any or all of the items which prices are quoted.

INDICATE WHETHER: INDIVIDUAL PARTNERSHIP CORPORATION

INCORPORATED IN:

NAME AND ADDRESS OF BIDDER:

CLAYARCH, INC.
P.O.Box 12577
Tamuning, Guam 96931

SIGNATURE AND TITLE OF PERSON
AUTHORIZED TO SIGN THIS BID:

Min Chul Kong, Vice President

AWARD:	CONTRACT NO.:	AMOUNT:	DATE:
ACCEPTED AS TO ITEMS NUMBERED:			

CONTRACTING OFFICER

GCC PRESIDENT

NAME AND ADDRESS OF CONTRACTOR:

SIGNATURE AND TITLE OF PERSON AUTHORIZED
TO SIGN THIS CONTRACT

ORIGINAL



Guam Community College
 PO Box 23069
 Barrigada, Guam 96921

Accountability • Impartiality • Competence • Openness • Value

INVITATION FOR BID (IFB) NO.: GCC-FB-21-009

DESCRIPTION: Replacement of Building 900 Metal Awning Structure

SPECIAL REMINDER TO PROSPECTIVE BIDDERS

Bidders are reminded to read the Sealed Bid Solicitation and Instructions, and General Terms and Conditions attached to the IFB to ascertain that all of the following requirements checked below are submitted in the bid envelope, original and two (2) copies, at the date and time for bid opening.

- BID GUARANTEE (15% OF BID AMOUNT) – May be in the form of:**
 - a. Cashier's Check or Certified Check
 - b. Letter of Credit (must not expire no earlier than ninety (90) days from the date of submittal); or
 - c. Surety Bond – Valid only if accompanied by:
 - 1. Current Certificate of Authority issued by the Insurance Commissioner;
 - 2. Power of Attorney issued by the Surety to the Resident General Agent;
 - 3. Power of Attorney issued by two (2) major officers of the Surety to whoever is signing on their behalf.
- BROCHURES/DESCRIPTIVE LITERATURE/Technical Specifications:** To make it easier to evaluate, please tab and reference each item number (18a – 18e) and highlight each specification requirement and attach the descriptive literature/product brochure for each respective item number.
- Project Narrative:** Describing how the qualified contractor will address this project's Scope of Work
- CPM Chart** (Critical Path Method) to illustrate the Qualified Contractor's timeline to complete the project, within (Ninety) 90 consecutive calendar days upon receipt of a purchase order & inclusive of the building permit, process & material lead time.
- Conceptual Design:** Illustrating the size and design of the awning.
- AFFIDAVIT OF DISCLOSING OWNERSHIP AND COMMISSIONS – Must comply with the following requirements:**
 - a. A bidder intends to participate in a bid opening on October 15 and submits his/her bid on September 12, the affidavit dated September 10 is acceptable
 - b. If the affidavit is a copy, indicate the Bid No. and where it is filed
- NON-COLLUSION AFFIDAVIT, AFFIDAVIT re: GRATUITIES AND KICKBACKS, AFFIDAVIT re: ETHICAL STANDARDS AND AFFIDAVIT re: CONTINGENT FEES (must be notarized)**
- Declaration Re Compliance with U.S. DOL Wage Determination:** Please see instructions in U.S. DOL Form
- Acknowledgement receipts of pre-bid minutes and or addendums upon issuance from Materials Management Office**
- Copy of current and valid Guam Contractors license (upon Issuance of Award)**
- Non-Refundable fee of \$25.00 must be paid on or before the Mandatory Pre-Bid Conference & Site Visit date.**

Failure to comply with the requirements in the special reminder will be a basis for disqualification and rejection of the bid. This reminder must be signed and returned in the bid envelope together with the bid. Failure to comply with the above requirements will mean a disqualification and rejection of the bid. On this 3rd day of June 2021, CLAYARCH, INC. acknowledge receipt of this special reminder to prospective bidders with the above referenced IFB.

Bidder Representative's Signature

GOVERNMENT OF GUAM

GUAM COMMUNITY COLLEGE
P.O. BOX 23069 GMF
BARRIGADA, GUAM 96921

BID BOND NO. N/A

KNOW ALL MEN BY THESE PRESENTS that CLAYARCH, INC., as Principal hereinafter called the Principal, and (Bonding Company), LEXON INSURANCE COMPANY a duly admitted insurer under the laws of the Territory of Guam, as Surety, hereinafter called the Surety are held firmly bound unto the Territory of Guam for the sum of FIFTEEN PERCENT OF ACCOMPANYING BID Dollars (\$15% OF BID), for payment of which sum will and truly to be made, the said(Principal and the said Surety bind ourselves, our heirs, executors, administrators, successors and assigns, jointly and severally, firmly by these presents.

WHEREAS, the Principal has submitted a bid for *(identify project by number and brief description)* BID INVITATION NO.: GCC-FB-21-009; BID FOR: REPLACEMENT OF BUILDING 900 METAL AWNING STRUCTURE

NOW THEREFORE, if the Territory of Guam shall accept the bid of the Principal and the Principal shall enter into a Contract with the Territory of Guam in accordance with the terms of such bid, and give such bond or bonds as may be specified in bidding or Contract Documents with good and sufficient surety for the faithful performance of such Contract and for the prompt payment of labor and material furnished in the prosecution, thereof, or in the event of the failure of the Principal to enter such Contract and give such bond or bonds, if the Principal shall pay to the Territory of Guam the difference not to exceed the penalty hereof between the amounts specified in said bid and such larger amount for which the Territory of Guam may in good faith contract with another party to perform work covered by said bid or an appropriate liquidated amount as specified in the Invitation for Bids then this obligation shall be null and void, otherwise to remain in full force and effect.

Signed and sealed this 27TH day of MAY 20 21

CLAYARCH, INC.

(PRINCIPAL) (SEAL)

(WITNESS)

(TITLE)
LEXON INSURANCE COMPANY

(MAJOR OFFICER OF SURETY)

ADAM T. BARON, ATTORNEY-IN-FACT
(TITLE)

LEXON INSURANCE COMPANY

(MAJOR OFFICER OF SURETY)

ADAM T. BARON, ATTORNEY-IN-FACT
(TITLE)

(RESIDENT GENERAL AGENT)
ADAM T. BARON, CASSIDY'S ASSOCIATED INSURERS, INC.

SEE INSTRUCTIONS IN BACK PAGE FOR SUPPORTING DOCUMENTS REQUIRED
DOA 113/Rev 4-1-87

GCC PR0175



SOMPO INTERNATIONAL
INSURANCE

POWER OF ATTORNEY

KNOW ALL BY THESE PRESENTS, that Endurance Assurance Corporation, a Delaware corporation, Endurance American Insurance Company, a Delaware corporation, Lexon Insurance Company, a Texas corporation, and/or Bond Safeguard Insurance Company, a South Dakota corporation, each, a "Company" and collectively, "Sompo International," do hereby constitute and appoint: Adam T. Baron, David W. Cassidy, Michael C. Cassidy, Timothy J. San Nicolas as true and lawful Attorney(s)-In-Fact to make, execute, seal, and deliver for, and on its behalf as surety or co-surety; bonds and undertakings given for any and all purposes, also to execute and deliver on its behalf as aforesaid renewals, extensions, agreements, waivers, consents or stipulations relating to such bonds or undertakings provided, however, that no single bond or undertaking so made, executed and delivered shall obligate the Company for any portion of the penal sum thereof in excess of the sum of TEN MILLION DOLLARS (\$10,000,000.00).

Such bonds and undertakings for said purposes, when duly executed by said attorney(s)-in-fact, shall be binding upon the Company as fully and to the same extent as if signed by the President of the Company under its corporate seal attested by its Corporate Secretary.

This appointment is made under and by authority of certain resolutions adopted by the sole shareholder of each Company by unanimous written consent effective the 15th day of June, 2019, a copy of which appears below under the heading entitled "Certificate".

This Power of Attorney is signed and sealed by facsimile under and by authority of the following resolution adopted by the sole shareholder of each Company by unanimous written consent effective the 15th day of June, 2019 and said resolution has not since been revoked, amended or repealed:

RESOLVED, that the signature of an individual named above and the seal of the Company may be affixed to any such power of attorney or any certificate relating thereto by facsimile, and any such power of attorney or certificate bearing such facsimile signature or seal shall be valid and binding upon the Company in the future with respect to any bond or undertaking to which it is attached.

IN WITNESS WHEREOF, each Company has caused this instrument to be signed by the following officers, and its corporate seal to be affixed this 15th day of June, 2019.

Endurance Assurance Corporation
By: *Richard M Appel*
Richard Appel, SVP & Senior Counsel



Endurance American Insurance Company
By: *Richard M Appel*
Richard Appel, SVP & Senior Counsel



Lexon Insurance Company
By: *Richard M Appel*
Richard Appel, SVP & Senior Counsel



Bond Safeguard Insurance Company
By: *Richard M Appel*
Richard Appel, SVP & Senior Counsel



ACKNOWLEDGEMENT

On this 15th day of June, 2019, before me, personally came the above signatories known to me, who being duly sworn, did depose and say that they are the officer of each of the Companies; and that he executed said instrument on behalf of each Company by authority of his office under the by-laws of each Company.

By: *Amy Taylor*
Amy Taylor, Notary Public - My Commission Expires 5/9/23

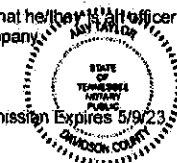

CERTIFICATE

I, the undersigned Officer of each Company, DO HEREBY CERTIFY that:

1. That the original power of attorney of which the foregoing is a copy was duly executed on behalf of each Company and has not since been revoked, amended or modified; that the undersigned has compared the foregoing copy thereof with the original power of attorney, and that the same is a true and correct copy of the original power of attorney and of the whole thereof;
2. The following are resolutions which were adopted by the sole shareholder of each Company by unanimous written consent effective June 15, 2019 and said resolutions have not since been revoked, amended or modified:

'RESOLVED, that each of the individuals named below is authorized to make, execute, seal and deliver for and on behalf of the Company any and all bonds, undertakings or obligations in surety or co-surety with others: RICHARD M. APPEL, BRIAN J. BEGGS, CHRISTOPHER DONELAN, SHARON L. SIMS, CHRISTOPHER L. SPARRO, MARIANNE L. WILBERT

; and be it further

RESOLVED, that each of the individuals named above is authorized to appoint attorneys-in-fact for the purpose of making, executing, sealing and delivering bonds, undertakings or obligations in surety or co-surety for and on behalf of the Company."

3. The undersigned further certifies that the above resolutions are true and correct copies of the resolutions as so recorded and of the whole thereof.

IN WITNESS WHEREOF, I have hereunto set my hand and affixed the corporate seal this 27TH day of MAY, 2021

By: *Daniel S. Lurie*
Daniel S. Lurie, Secretary

NOTICE: U. S. TREASURY DEPARTMENT'S OFFICE OF FOREIGN ASSETS CONTROL (OFAC)

No coverage is provided by this Notice nor can it be construed to replace any provisions of any surety bond or other surety coverage provided. This Notice provides information concerning possible impact on your surety coverage due to directives issued by OFAC. Please read this Notice carefully.

The Office of Foreign Assets Control (OFAC) administers and enforces sanctions policy, based on Presidential declarations of "national emergency". OFAC has identified and listed numerous foreign agents, front organizations, terrorists, terrorist organizations, and narcotics traffickers as "Specially Designated Nationals and Blocked Persons". This list can be located on the United States Treasury's website - <https://www.treasury.gov/resource-center/sanctions/SDN-List>

In accordance with OFAC regulations, if it is determined that you or any other person or entity claiming the benefits of any coverage has violated U.S. sanctions law or is a Specially Designated National and Blocked Person, as identified by OFAC, any coverage will be considered a blocked or frozen contract and all provisions of any coverage provided are immediately subject to OFAC. When a surety bond or other form of surety coverage is considered to be such a blocked or frozen contract, no payments nor premium refunds may be made without authorization from OFAC. Other limitations on the premiums and payments may also apply.

Any reproductions are void.

Surety Claims Submission: LexonClaimAdministration@sompo-intl.com

Telephone: 616-653-9500 Mailing Address: Sompo International; 12880 Lebanon Road; Mount Juliet, TN 37122-2870

GOVERNMENT OF GUAM
DEPARTMENT OF REVENUE AND TAXATION
OFFICE OF THE BANKING AND INSURANCE COMMISSIONER
CERTIFICATE OF AUTHORITY
RENEWAL
COA383

Know All Men By These Presents That:

Name LEXON INSURANCE COMPANY

Address 701 BRAZOS STREET
AUSTIN, TX 78701

SUITE 1500

Classes of Insurance
Authorized

Fidelity & Surety

Having complied with the Insurance Law of Guam, is hereby authorized to transact as an insurer, the above named Classes of Insurance in Guam from the 1st day of July, 2020 to the 1st day of July, 2021 unless authority is revoked for failure to comply with the law.

General Agent(s):

TAKAGI & ASSOCIATES INC
CASSIDY'S ASSOCIATED INSURERS INC

In Witness Whereof, I have hereunto subscribed my name officially and have hereon impressed my Seal of Office at the City of Hagatña, Guam on this 1st day of July, 2020

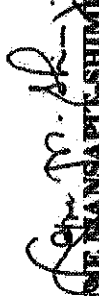
DAFNE NANSAPIT-SHINOBU
Acting Banking & Insurance Commissioner

AFFIDAVIT DISCLOSING OWNERSHIP AND COMMISSIONS

CITY OF Tamuning)
) ss.
 ISLAND OF GUAM)

A. I, the undersigned, being first duly sworn, depose and say that I am an authorized representative of the offeror and that *[please check only one]*:

The offeror is an individual or sole proprietor and owns the entire (100%) interest in the offering business.

The offeror is a corporation, partnership, joint venture, or association known as CLAYARCH, INC. *[please state name of offeror company]*, and the persons, companies, partners, or joint venturers who have held more than 10% of the shares or interest in the offering business during the 365 days immediately preceding the submission date of the proposal are as follows *[if none, please so state]*:

<u>Name</u>	<u>Address</u>	<u>% of Interest</u>
<u>Hak Joong Kim</u>	<u>D204 Summer Sky Apt. Tamuning</u>	<u>55%</u>
<u>Min Chul Kong</u>	<u>120 Mansanita Ln. Tamuning</u>	<u>45%</u>

B. Further, I say that the persons who have received or are entitled to receive a commission, gratuity or other compensation for procuring or assisting in obtaining business related to the bid or proposal for which this affidavit is submitted are as follows *[if none, please so state]*:

<u>Name</u>	<u>Address</u>	<u>Compensation</u>
<u>N/A</u>		

C. If the ownership of the offering business should change between the time this affidavit is made and the time an award is made or a contract is entered into, then I promise personally to update the disclosure required by 5 GCA §5233 by delivering another affidavit to the government.



 Signature of one of the following:

Offeror, if the offeror is an individual;
 Partner, if the offeror is a partnership;
 Officer, if the offeror is a corporation.

Subscribed and sworn to before me
 this 1st day of June, 2021.

 NOTARY PUBLIC
 My commission expires: July 07, 2022

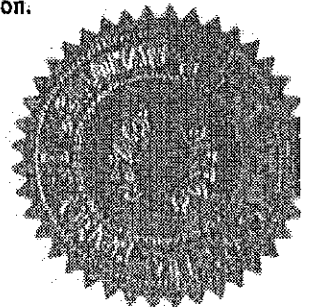
MARIA M.B. DELLOMAS
 NOTARY PUBLIC
 In and for Guam, U.S.A.
 My Commission Expires: **JULY 07, 2022**
 PMB 884 111 Chalan Balaka Machanao
 Dededo, Guam 96929



AFFIDAVIT RE ETHICAL STANDARDS

CITY OF Tamuning)
) SS.
ISLAND OF GUAM)

Min Chul Kong [state name of affiant signing below], being first
duly sworn, deposes and says that:

The affiant is CLAYARCH, INC. [state one of the following: the offeror, a
partner of the offeror, an officer of the offeror] making the foregoing identified bid or proposal. To the best
of affiant's knowledge, neither affiant nor any officers, representatives, agents, subcontractors or employees
of offeror have knowingly influenced any government of Guam employee to breach any of the ethical
standards set forth in 5 GCA Chapter 5, Article 11. Further, affiant promises that neither he or she, nor any
officer, representative, agent, subcontractor, or employee of offeror will knowingly influence any
government of Guam employee to breach any ethical standards set forth in 5 GCA Chapter 5, Article 11.
These statements are made pursuant to 2 GAR Division 4 § 11103(b).



Signature of one of the following:

Offeror, if the offeror is an individual;
Partner, if the offeror is a partnership;
Officer, if the offeror is a corporation.

Subscribed and sworn to before me
this 1st day of June, 2021.

NOTARY PUBLIC
My commission expires July 07, 2022.

MARIA M.B. DELLOMAS
NOTARY PUBLIC
In and for Guam, U.S.A.
My Commission Expires: JULY 07, 2022
PMB 884 111 Chalan Batako Mashanao
Dededo, Guam 96929

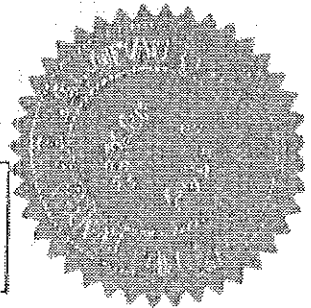

AFFIDAVIT RE CONTINGENT FEES

CITY OF Tamuning)
) ss.
ISLAND OF GUAM)

Min Chul Kong [state name of affiant signing below], being first duly sworn, deposes and says that:

1. The name of the offering company or individual is [state name of company] CLAYARCH, INC.
2. As a part of the offering company's bid or proposal, to the best of my knowledge, the offering company has not retained any person or agency on a percentage, commission, or other contingent arrangement to secure this contract. This statement is made pursuant to 2 GAR Division 4 11108(f).
3. As a part of the offering company's bid or proposal, to the best of my knowledge, the offering company has not retained a person to solicit or secure a contract with the government of Guam upon an agreement or understanding for a commission, percentage, brokerage, or contingent fee, except for retention of bona fide employees or bona fide established commercial selling agencies for the purpose of securing business. This statement is made pursuant to 2 GAR Division 4 11108(h).
4. I make these statements on behalf of myself as a representative of the offeror, and on behalf of the offeror's officers, representatives, agents, subcontractors, and employees.

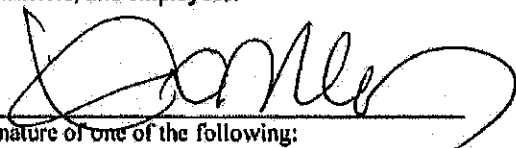
Signature of one of the following:

Offeror, if the offeror is an individual;
Partner, if the offeror is a partnership;
Officer, if the offeror is a corporation.

Subscribed and sworn to before me
this 1st day of June, 20 21.

NOTARY PUBLIC
My commission expires July 07, 2022.

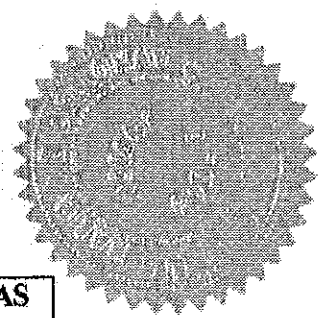

MARIA M.B. DELLOMAS
NOTARY PUBLIC
In and for Guam, U.S.A.
My Commission Expires: **JULY 07, 2022**
PMB 884 111 Chalan Balako Machanao
Dededo, Guam 96929

install barricades and other materials to prevent damages on nearby places that will be affected by the construction and also precautions to ensure the public safety. The Contractor will make arrangements and administer meetings throughout progress of the work and will be scheduled as advised by the owner.

QUALITY CONTROL

The contractor is responsible for the overall quality of the work performed by the contractor and subcontractors working under this project. The quality of any part of the work must not be less than that required by the contract documents. If the owner's representative determines that the quality of the work does not conform to the contract document, the owner's representative will notify the contractor, in writing. Monitor quality control over the contractor's staff, subcontractors, suppliers, manufacturers, products, services, site conditions and workmanship. Comply fully with the manufacturer's published instructions, including each step in the sequence of installation. Comply with the specified standards as a minimum quality for the work, except where more stringent tolerances, codes or specified requirements indicate higher standards or more precise workmanship.

CONSTRUCTION PROGRESS

Mobilization

Provide temporary barrier fence which is 8 feet high, signage, traffic control, disposal dumpster and personnel necessary for public safety. Any road or area that will be obstructed will have signs, barriers, warning pedestrians and road users of these hazards. Protection of any existing structures that may be affected by this works such as adjacent buildings, trees, adjacent rooms will be protected to avoid accidental damage. Controlling and enclosure of the work area boundaries. Prepare and store the materials in a proper place. Put warning signs where construction works will perform.

Demolition works

Provide mobilize the appropriate equipment boom truck, scissor lift to the jobsite. First step - remove the existing metal gutter, downspouts, flashing, roof tin panel. Second step - remove the existing metal beam and column. After the demolition work is completed, dispose all materials of existing awning and clean up the job site.

Erection for Metal Structural and Roof Tin Panel

All material is carefully checked and loaded to ensure safe delivery and to avoid shortages. Material are packaged and can be unloaded by use of heavy-duty fork-lift or by crane.

Erection procedure for main structural frame – Using crane to lift columns and installing columns and beam. Installing full purlins S-layer and 2'-6" overlap. Installing full roof bracing, tube struts and flange brace. Checking and aligning first bay before next rafter. When completed 2bays must start to fix purlin blocks. Installing roof bracing and flange brace. Continue to install step to step.

Installation procedure for roofing, cladding, flashing and trims – fixing rack support and rack angle and installing first 22-gauge thickness corrugated roof sheet panels with fixing screw at eave. Continue to install roof tin panel. Installing flashing, gutter, and downspouts. Apply the awning and roofing sealant for fastener and joint protection and leak prevention. Apply oil-based primer and 2-coats final paint on column, beam, and corrugated roof sheet panels. Re-install 7-lighting fixtures

CLEANING AND PROTECTION

During handling and installation of work at the project site, clean and protect work in progress and the adjoining work on a basis of perpetual maintenance. Apply suitable protective covering over newly installed



P.O BOX 12577 TAMUNING, GUAM 96931
Tel. (671) 646-8842 Fax. (671) 646-8843
E-mail: admin@clayarchinc.com
Website: www.clayarchinc.com

work where reasonably required to ensure freedom from damage and deterioration at the time of substantial completion; otherwise, clean and perform maintenance on newly installed work as frequently as necessarily throughout the remainder of the construction period. Adjust and lubricate operable components to ensure operability without damaging effects. Complete cleaning operations before requesting inspection for substantial completion for final acceptance of the project.

TESTING AND INSPECTION

Test and inspect the work provide under this contract to ensure that the work is in compliance with the contract requirements. Require tests and inspections are indicated in the individual specification sections. Prior to final acceptance by the owner's representation, submit a certification signed by the contractor stating that all work has been inspected and that all work, except as specifically noted, is complete and in compliance with the contract documents.

WARRANTY

All work shall be guaranteed in writing by the contractor against defects resulting from the use of defective or inferior materials, equipment, or workmanship, for a minimum of two (2) years from the date of substantial completion. Any maintenance service contracts and warranties for equipment in use shall begin as of the same date of the general warranty against defects described herein above.

ID	Task Name	Duration	Start	Finish	Predecessors	June	July	August	September	October
1	GCC-PR-21-009 REPLACEMENT OF BUILDING 900 METAL AWNING STRUCTURE	90 days	Tue 21-07-01	Tue 21-09-28						
2	MOBILIZATION	9 days	Fri 21-07-01	Fri 21-07-09						
3	GCC PURCHASE ORDER	2 days	Fri 21-07-01	Fri 21-07-02						
4	DRAWING AND MATERIAL SUBMITTAL	7 days	Sat 21-07-03	Fri 21-07-09	3					
5	CONSTRUCTION	88 days	Sat 21-07-03	Tue 21-09-28						
6	MOBILIZATION AND DEMOLITION	24 days	Sat 21-07-03	Mon 21-07-28						
7	TEMPORARY BARRIER	7 days	Sat 21-07-03	Fri 21-07-09	3					
8	REMOVAL OF GUTTER AND DOWNSPOUT	4 days	Sat 21-07-10	Tue 21-07-13	7					
9	REMOVAL OF ROOF TIN PANEL	7 days	Sat 21-07-10	Fri 21-07-16	7					
10	REMOVAL OF METAL BEAM AND COLUMN	7 days	Sat 21-07-17	Fri 21-07-23	9					
11	DISPOSAL AND CLEARING	3 days	Sat 21-07-24	Mon 21-07-26	10					
12	ERECTOR OF STEEL STRUCTURAL	84 days	Tue 21-07-27	Tue 21-09-28						
13	DELIVERY OF MATERIALS	2 days	Tue 21-07-27	Wed 21-07-28	11					
14	REPAIR AND INSTALLATION OF ANCHOR BOLT	5 days	Thu 21-07-29	Mon 21-08-02	13					
15	INSTALLATION OF NEW METAL COLUMN AND BEAM	14 days	Tue 21-08-03	Mon 21-08-16	14					
16	INSTALLATION OF CABLE BRACING	2 days	Tue 21-08-17	Wed 21-08-18	15					
17	INSTALLATION OF PURLIN	5 days	Thu 21-08-19	Mon 21-08-23	16					
18	INSTALLATION OF ROOF BUTLER TIN	14 days	Tue 21-08-24	Mon 21-09-06	17					
19	INSTALLATION OF FLASHING	2 days	Tue 21-09-07	Wed 21-09-08	18					
20	INSTALLATION OF GUTTER AND DOWNSPOUTS	6 days	Thu 21-09-09	Tue 21-09-14	19					
21	APPLICATION OF OIL BASED PAINT	5 days	Wed 21-09-15	Sun 21-09-19	20					
22	APPLICATION OF SEALANT	3 days	Mon 21-09-20	Wed 21-09-22	21					
23	RE-INSTALLATION OF LIGHTING FIXTURES	3 days	Thu 21-09-23	Sat 21-09-25	22					
24	TESTING AND INSPECTION	3 days	Sun 21-09-26	Tue 21-09-28	23					

Project: GCC-PR-21-009
Date: Tue 21-08-01

Task: Progress Milestone

Summary: Project Summary

External Topics: External Milestone

Deadline:

Page 1

PROJECT: PROPOSED REPLACING DEGRADED AWNING @ BUILDING 500 SHEET: 001/01		DATE: 08/14/2014 DRAWN BY: [Name]	
CLIENT: [Name]		PROJECT NO: [Number]	
SCALE: [Scale]		DATE: [Date]	
DRAWN BY: [Name]		CHECKED BY: [Name]	
APPROVED BY: [Name]		DATE: [Date]	

A-1

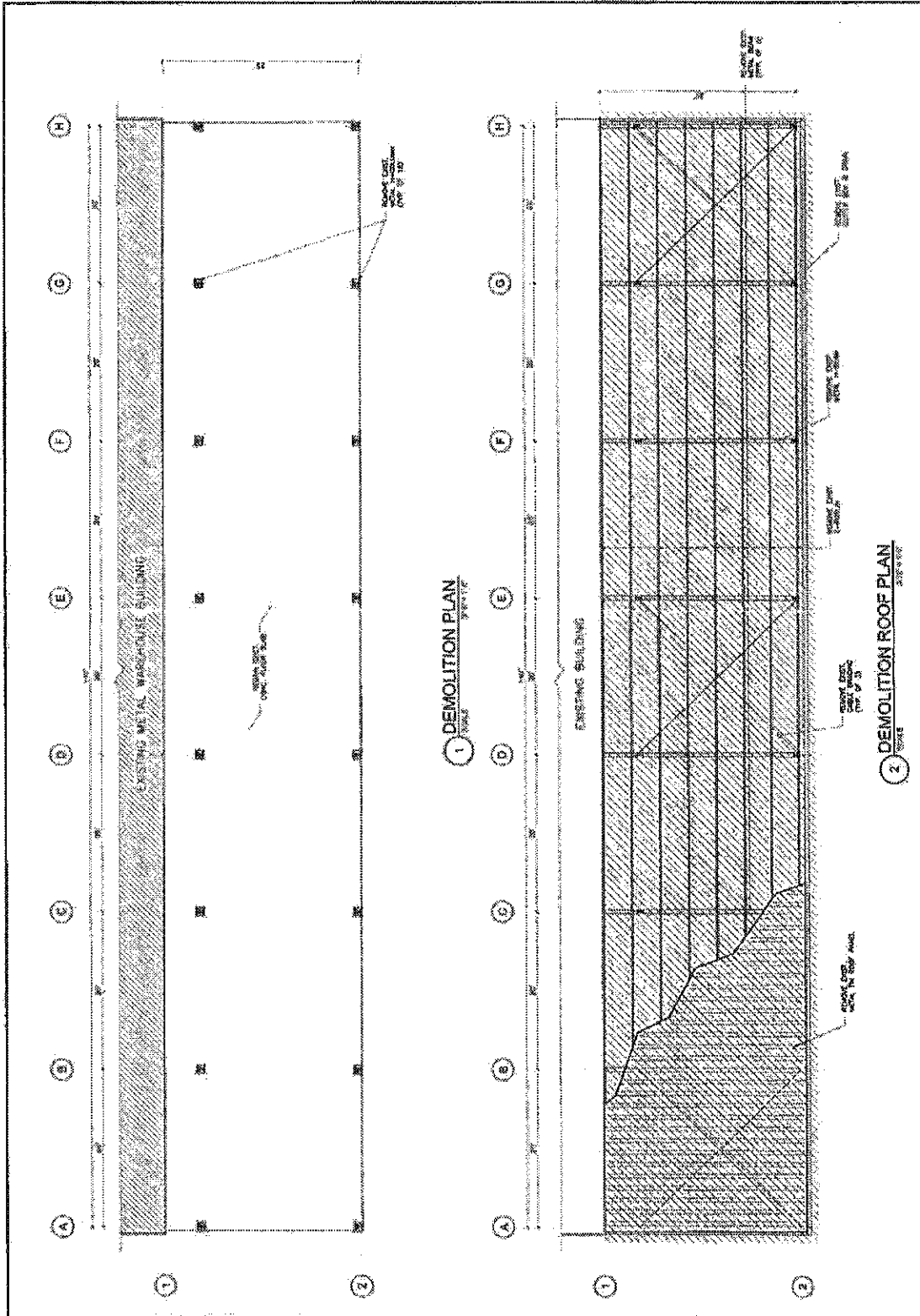

PROJECT PROPOSED REPLACING & UPDATED AWNING @ BUILDING 900		LOCATION LOT 111N-100-1-4	DATE 10/11/2017
DESIGNER GARR COMPANY ENGINEERS		CLIENT METS COMPANY	SCALE AS SHOWN
NO. OF SHEETS 1	SHEET NO. A-2	TOTAL SHEETS 1	DATE 10/11/2017
DATE 10/11/2017	SCALE AS SHOWN	PROJECT NUMBER 17-0000000000	PROJECT NAME PROPOSED REPLACING & UPDATED AWNING @ BUILDING 900
DATE 10/11/2017	SCALE AS SHOWN	PROJECT NUMBER 17-0000000000	PROJECT NAME PROPOSED REPLACING & UPDATED AWNING @ BUILDING 900
DATE 10/11/2017	SCALE AS SHOWN	PROJECT NUMBER 17-0000000000	PROJECT NAME PROPOSED REPLACING & UPDATED AWNING @ BUILDING 900
DATE 10/11/2017	SCALE AS SHOWN	PROJECT NUMBER 17-0000000000	PROJECT NAME PROPOSED REPLACING & UPDATED AWNING @ BUILDING 900
DATE 10/11/2017	SCALE AS SHOWN	PROJECT NUMBER 17-0000000000	PROJECT NAME PROPOSED REPLACING & UPDATED AWNING @ BUILDING 900
DATE 10/11/2017	SCALE AS SHOWN	PROJECT NUMBER 17-0000000000	PROJECT NAME PROPOSED REPLACING & UPDATED AWNING @ BUILDING 900

A-2

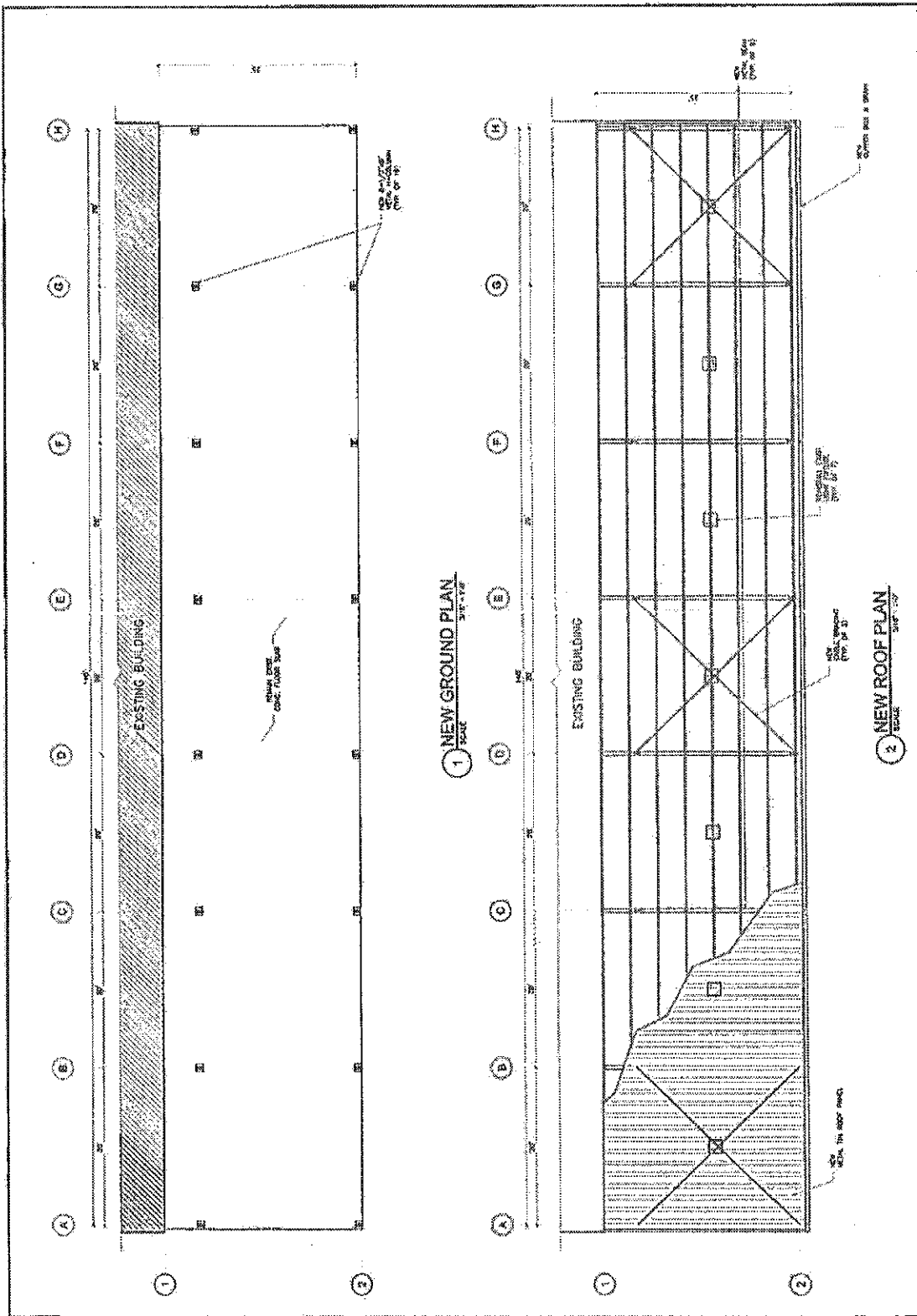

PROJECT: PROPOSED REPLACING DIAPHRAGMS AT BLDG. NO. 500		DATE: 11/14/02	BY: [Signature]
LOCATION: 1411 22ND AVE. S.W.		PROJECT NUMBER: 02-0000	SCALE: AS SHOWN
DESIGNED BY: [Signature]	CHECKED BY: [Signature]	DATE: 11/14/02	BY: [Signature]
PROJECT NUMBER: 02-0000	DATE: 11/14/02	BY: [Signature]	SCALE: AS SHOWN
PROJECT NUMBER: 02-0000	DATE: 11/14/02	BY: [Signature]	SCALE: AS SHOWN

A-3

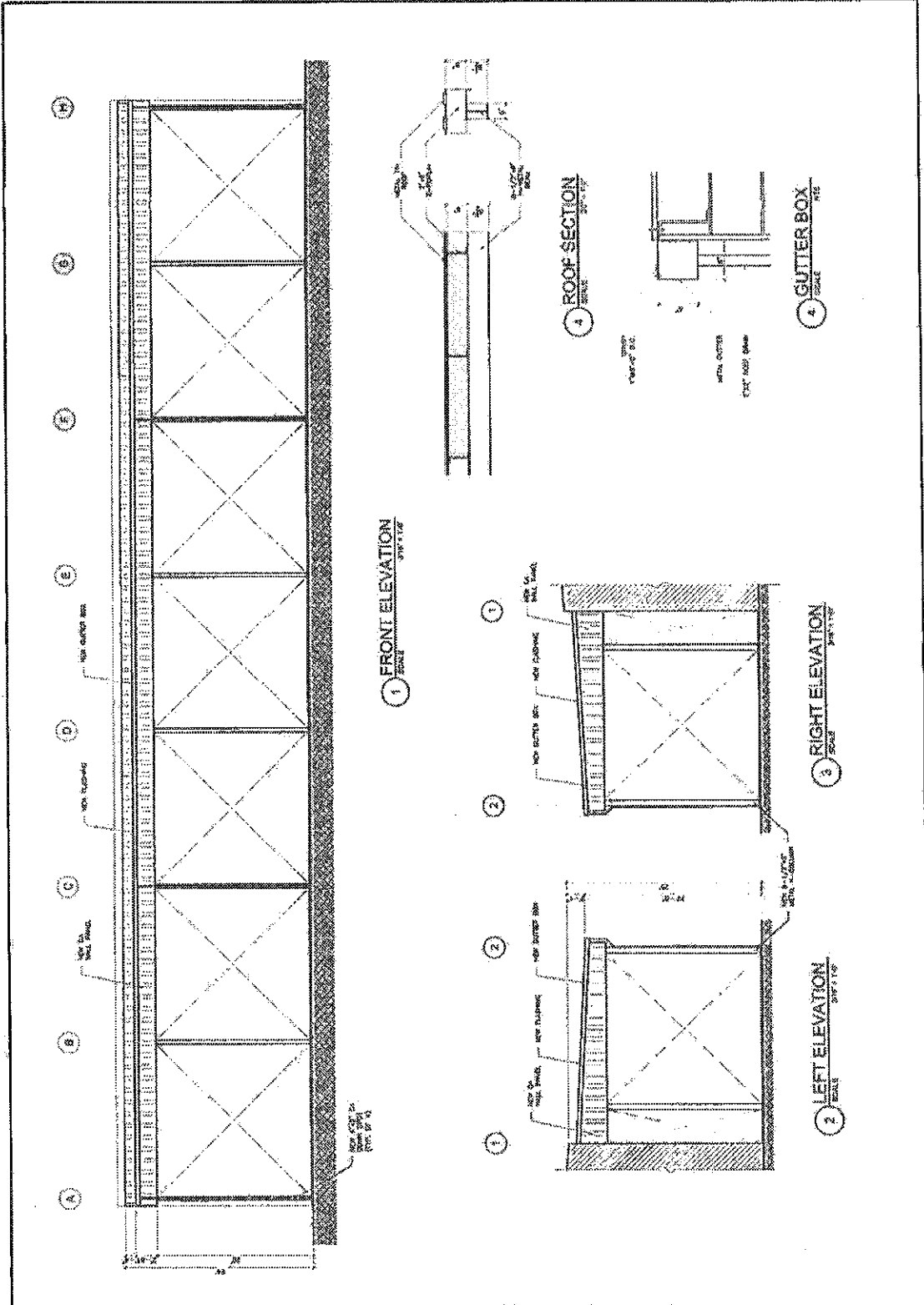

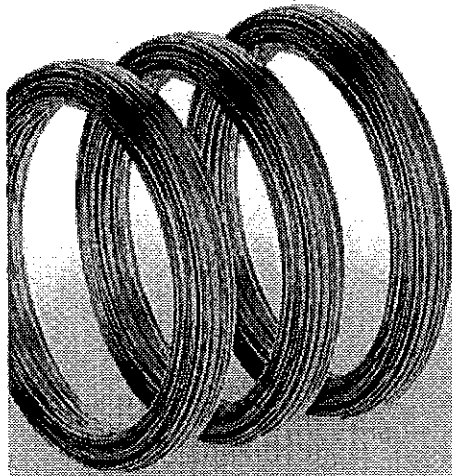
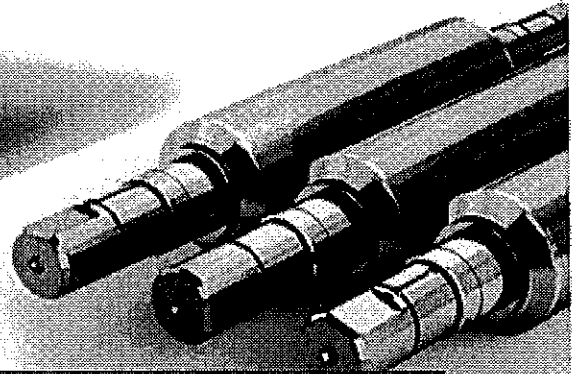
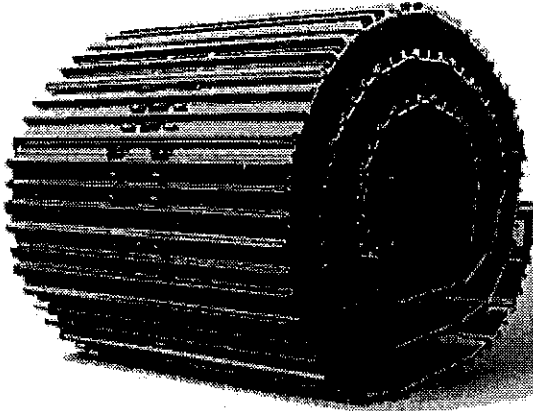
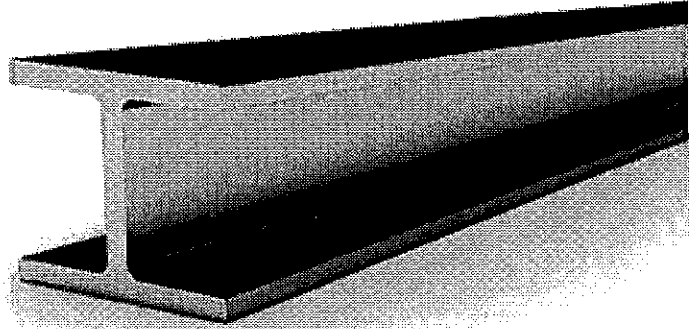
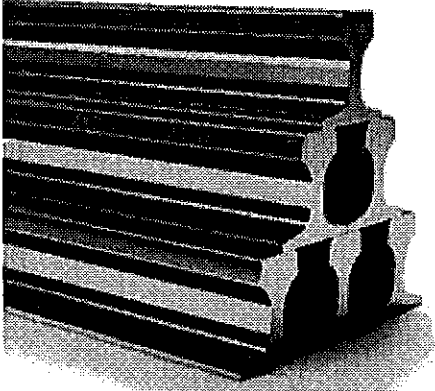
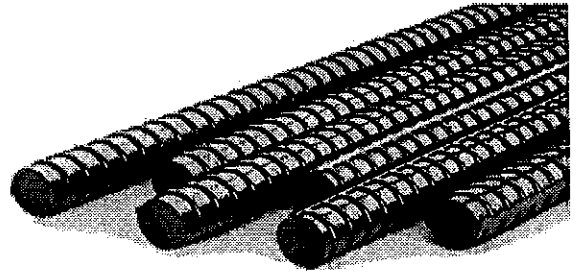

Product Guide
현대제철 종합 제품소개 | PART 2



HYUNDAI
STEEL

01. H Section H형강

Dimensions and Sectional Properties 치수 및 단면성능



(1) Metric Series - KS, JIS '90

표명치수 Division (depth x width)	단면무게 Unit Weight (kg/m)	표준단면치수 Standard Sectional Dimension (mm)					단면적 Sectional Area (cm ²)	단면 2차 모멘트 Moment of Inertia (cm ⁴)	
		H	B	t ₁	t ₂	r		I _x	I _y
100 x 100	17.2	100	100	6	8	10	21.50	383	134
125 x 125	23.8	125	125	6.5	9	10	30.31	647	293
150 x 75	14.0	150	75	5	7	8	17.85	666	49.5
150 x 100	21.1	148	100	6	9	11	26.84	1,030	151
150 x 150	31.5	150	150	7	10	11	40.14	1,640	563
200 x 100	18.2	199	99	4.5	7	11	23.18	1,380	114
	21.3	200	100	5.5	8	11	27.16	1,840	134
200 x 150	30.6	194	150	6	9	13	39.01	2,600	507
200 x 200	49.9	200	200	8	12	13	63.53	4,720	1,600
	56.2	200	204	12	12	13	71.53	4,980	1,700
	65.7	208	202	10	16	13	83.69	6,530	2,200
250 x 125	25.7	248	124	5	8	12	32.68	3,540	295
	29.6	250	125	6	9	12	37.66	4,050	294
250 x 175	44.1	244	175	7	11	16	56.24	6,120	985
250 x 250	64.4	244	252	11	11	16	82.05	8,750	2,940
	66.5	248	249	8	13	16	84.70	9,930	3,350
	72.4	250	250	9	14	16	92.18	10,800	3,650
	82.2	250	255	14	14	16	104.7	11,500	3,850
300 x 150	32.0	298	149	5.5	8	13	40.80	4,320	442
	36.7	300	150	6.5	9	13	48.75	7,210	508
300 x 200	56.8	294	200	8	12	18	72.38	11,300	1,600
	65.4	298	201	9	14	18	83.36	13,900	1,900
300 x 300	84.5	294	302	12	12	18	107.7	16,900	5,520
	87.0	298	299	9	14	18	110.8	18,800	6,240
	94.0	300	300	10	15	18	119.8	20,400	6,750
	106	300	305	15	15	18	134.6	21,500	7,100
	108	304	301	11	17	18	134.8	23,400	7,730
	130	310	308	15	20	18	165.3	28,600	9,430
142	310	310	20	20	18	180.8	29,900	10,000	



ROOFING TINS

(Made in U.S.A)
from imported material

BUTLER TYPE White/Blue prepainted, ASTM A792

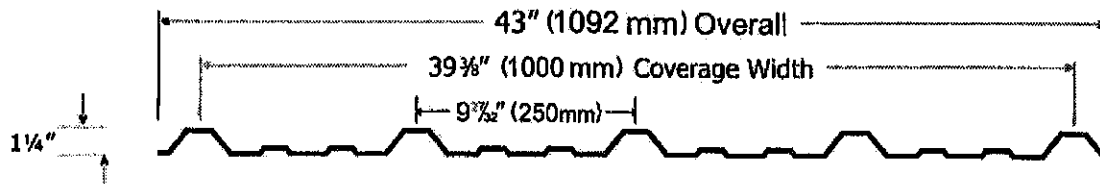

GAUGE	THICKNESS (in)	WEIGHT (psf)	YIELD (ksi)
26 GA	0.019	.0932	AZ-50

FASTENING DETAILS



CORRUGATED Galvalume Coating, ASTM A792

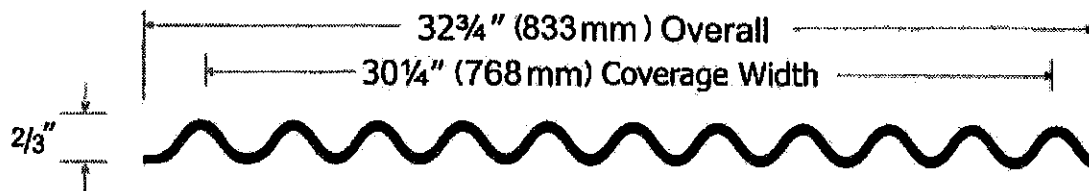

GAUGE	THICKNESS (in)	WEIGHT (psf)	YIELD (ksi)
26 GA	0.019	.0932	AZ-50

FASTENING DETAILS





CONWOOD PRODUCTS, INC

PREPAINTED 55 % AL-ZN ALLOY COATED STEEL SHEETS IN COIL (BUTLER TIN)

BASE METAL: ASTM A792 CQ , AZ50 COATING
PAINT: RPM , TOP / BLACK = 1.0 MIL / 0.2 MIL EPOXY PRIMER
COLOR: TOP/BLACK = WHITE (X384) EPOXY GREY (N522)
COIL ID 20th : COIL WT 5.0 M/T MAW WITH EYE TO SKY ON SKIDS
MINIMUM GAUGE (TCT): BASE METAL + AL-ZN (EXCLUDING PAINT THICKNESS)
COILING: TOP COLOR OUTSIDE, ACTUAL WEIGHT BILLING
END USAGE FOR ROOFING and OTHERS (ROLL FORMING)

More detailed , refer to MILL TEST CERTIFICATE.

Main 1701 W. 31 Street • Vancouver, Washington 98660
Office: PH: 360-694-5195 • FAX: 360-694-5096
PH: 503-283-3151
www.conwoodproducts.com

Guam Box 21448 • GMF, Guam 96921
Office: PH: 671-632-3424/6/7/8 • FAX: 671-632-2824
Saipan P.O.Box 504459 • Saipan, MP 96950
Office: PH: 670-235-3500/01/02 • Fax: 670-235-3503

GCC PR0193

MILL TEST CERTIFICATE

MESSRS. DONGKUK INTERNATIONAL, INC.



DATE : 2018.12.30
MTC NO : US-1-181222-002
ORDER NO : E181122050
INVOICE NO : D20181220B008
LC NO. : T/T
PO NO. : LGL201812013

COMMODITY : HOT DIP ALUMINUM ZINC ALLOY COATED STEEL SHEET/COIL
SPECIFICATION : ASTM A792 COMMERCIAL QUALITY AZ50 COATING

COIL NO.	SIZE	WEIGHT		CHEMICAL COMPOSITION(%)						TENSILE TEST	ALLOY COATING (g/m ²)	HEAT NO.	SURFACE FINISHING									
		NET Wt (kg)	GROSS Wt (kg)	C	Si	Mn	P	S	Al				Fe	T/B (%)	Coating (g/m ²)	Coating (g/m ²)	Coating (g/m ²)					
D10-00001 ACH850M	0.5MM MIN X 914MM X COIL	4,750 10,472	4,780 10,538	38	6	197	9	6	29	0	59	9.1	321	395	31.3	G	155.5	SB03835	0.0	0.0	0.0	0.0
D10-00002 ACH850M	0.5MM MIN X 914MM X COIL	4,740 10,450	4,770 10,516	38	6	197	9	6	29	0	59	9.1	321	395	31.3	G	155.5	SB03835	0.0	0.0	0.0	0.0
D10-00003 ACH850P	0.5MM MIN X 914MM X COIL	4,750 10,472	4,780 10,538	38	6	197	9	6	29	0	59	9.1	321	395	31.3	G	155.5	SB03835	0.0	0.0	0.0	0.0
D10-00004 ACH850Q	0.5MM MIN X 914MM X COIL	4,810 10,605	4,840 10,671	39	6	197	9	6	29	0	59	9.1	321	395	31.3	G	155.5	SB03835	0.0	0.0	0.0	0.0
D10-00005 ACH850R	0.5MM MIN X 914MM X COIL	4,730 10,429	4,760 10,494	36	4	183	11	7	24	0	56.5	9.1	320	389	30.3	G	151.9	SB03842	0.0	0.0	0.0	0.0
D10-00006 ACH850S	0.5MM MIN X 914MM X COIL	4,720 10,408	4,750 10,472	35	4	183	11	7	24	0	56.5	9.1	320	389	30.3	G	151.9	SB03842	0.0	0.0	0.0	0.0
D10-00007 ACH850T	0.5MM MIN X 914MM X COIL	4,720 10,408	4,750 10,472	35	4	183	11	7	24	0	56.5	9.1	320	389	30.3	G	151.9	SB03842	0.0	0.0	0.0	0.0

REMARK:

COLOR CODE (TOP/BACK)

CHIEF OF QUALITY CONTROL TEAM

We hereby certify that the material herein has been made and tested in accordance with the above specification and the results of all test are acceptable.

T: TOP
B: BACK
G: GROSS
GROSS Wt

① :
② :
③ :
④ :

MANUFACTURER: DONGKUK STEEL MILL CO., LTD. (DONGKUK STEEL) 102 SINSEON-RO, NAM-GU, BUSAN, KOREA ZIP 48481, TEL : 82-51-640-5114

Page : 1 / 3

MADE IN KOREA A4(210 X 297)

MILL TEST CERTIFICATE



MESSRS. DONGKUK INTERNATIONAL, INC.

DATE : 2018.12.30
 MTC NO : UG1-1-18122-002
 ORDER NO : E18122050
 INVOICE NO : D201812205008
 LIC NO. : TTT
 PRO NO. : LGL201812013

COMMODITY : HOT DIP ALUMINUM ZINC ALLOY COATED STEEL SHEET/COIL
 SPECIFICATION : ASTM A792 COMMERCIAL QUALITY AZ50 COATING

COIL NO.	SIZE	WEIGHT		CHEMICAL COMPOSITION(%)										TENSILE TEST		YIELD POINT (MPa)	Elongation (%)	HEAT No.	SPANGLE
		NET WT (KG/50)	GROSS WT (KG/50)	C	SI	Mn	P	S	Al	B	Zn	Fe	MPa	%					
010-00008 ACH850U	0.5MM MIN X 914MM X COIL	4,750 10,472	4,750 10,536	35	4	183	11	7	24	0	58.5	9.1	320	389	30.3	G	151.9	5839842	CHROMATE / GALVA CLEAN(X-2 : PE DIF-81)
010-00009 ACH850V	0.5MM MIN X 914MM X COIL	4,720 10,406	4,750 10,472	43	4	184	9	7	26	0	58.6	9.1	324	403	32.4	G	154.2	5839839	CHROMATE / GALVA CLEAN(X-2 : PE DIF-81)
010-00010 ACH850W	0.5MM MIN X 914MM X COIL	4,730 10,428	4,750 10,494	43	4	184	9	7	26	0	58.6	9.1	324	403	32.4	G	154.2	5839839	CHROMATE / GALVA CLEAN(X-2 : PE DIF-81)
010-00011 ACH850X	0.5MM MIN X 914MM X COIL	4,730 10,428	4,750 10,494	43	4	184	9	7	26	0	58.6	9.1	324	403	32.4	G	154.2	5839839	CHROMATE / GALVA CLEAN(X-2 : PE DIF-81)
010-00012 ACH850Y	0.5MM MIN X 914MM X COIL	4,740 10,450	4,770 10,516	43	4	184	9	7	26	0	58.6	9.1	324	400	32.4	G	154.2	5839839	CHROMATE / GALVA CLEAN(X-2 : PE DIF-81)
010-00013 ACH850Z	0.5MM MIN X 914MM X COIL	4,750 10,472	4,780 10,538	38	6	187	9	6	29	0	58.9	9.1	330	405	31.7	G	153.9	5839835	CHROMATE / GALVA CLEAN(X-2 : PE DIF-81)
010-00014 ACH8510	0.5MM MIN X 914MM X COIL	4,740 10,450	4,770 10,516	38	6	187	9	6	29	0	58.9	9.1	330	405	31.7	G	153.9	5839835	CHROMATE / GALVA CLEAN(X-2 : PE DIF-81)

REMARK: COLOR CODE (TOPFACE)

①: We hereby certify that the material herein has been made and tested in accordance with the above specification and the results of all test are acceptable.

②: T: TOP

③: S: BACK

④: G: GOOD

⑤: GRS: WT: GROSS WT

MANUFACTURER: DONGKUK STEEL MILL CO., LTD. (DONGKUK STEEL) 103 SINSEON-RO, NAM-GU, BUSAN, KOREA ZIP 49481, TEL : 82-51-840-5114

USS-G-0913-01 REV.2

MADE IN KOREA A4(210 X 237)

MILL TEST CERTIFICATE



MESSRS: DONGKUK INTERNATIONAL, INC.

DATE : 2018.12.30
 MTC NO : UG1-181222-002
 ORDER NO : E181122050
 INVOICE NO : D201812208008
 LC NO. : T/T
 PRO NO. : LGL201812013

COMMODITY : HOT DIP ALUMINUM ZINC ALLOY COATED STEEL SHEET/COIL
 SPECIFICATION : ASTM A792 COMMERCIAL QUALITY AZ50 COATING

COIL NO.	SIZE	WEIGHT		CHEMICAL COMPOSITION(%)										HARDNESS	TENSILE TEST	AL-ZINC COATING (g/m²)	HEAT NO.	SURFACE FINISHING		
		NET WT (KGS)	GROSS WT (KGS)	C	SI	Mn	P	S	AL	B	HRB	YF	TS					EL	T/B	T/B
010-00015 ACH8511	915MM MIN X 914MM X COIL	4,740 10,450	4,770 10,515	36	6	197	9	6	29	0	59.0	9.1	330	405	31.7	153.9	SBS6835	0.0	0	0
010-00016 ACH8512	915MM MIN X 914MM X COIL	4,810 10,605	4,840 10,671	36	6	197	9	6	29	0	59.0	9.1	330	405	31.7	153.9	SBS6835	0.0	0	0
TOTAL		9,550 167,400	9,610 167,455																	

REMARK:	COLOR CODE (TOP/BACK)	CHIEF OF QUALITY CONTROL TEAM
---------	-----------------------	-------------------------------

①: We hereby certify that the material herein has been made and tested in accordance with the above specification and the results of all test are acceptable.

②: T: TOP
 ③: B: BACK
 ④: G: GOOD
 ⑤: GRS wt.: GROSS wt

MANUFACTURER: DONGKUK STEEL MILL CO., LTD. (DONGKUK STEEL) 102 SINSEON-RO, NAM-GU, BUSAN, KOREA ZIP 49481, TEL: 82-51-640-5114

USS-G-0913-01 REV.2

MADE IN KOREA A4(210 X 297)

Page : 3 / 3

DECLARATION RE COMPLIANCE WITH U.S. DOL WAGE DETERMINATION

Procurement No.: GCC-FB-21-009

Name of Offeror Company: CLAYARCH, INC.

I, Min Chul Kong hereby certify under penalty of perjury:

(1) That I am the offeror [please select one: the offeror, a partner of the offeror, an officer of the offeror] making the bid or proposal in the foregoing identified procurement;

(2) That I have read and understand the provisions of 5 GCA § 5801 and § 5802 which read:

§ 5801. Wage Determination Established.

In such cases where the government of Guam enters into contractual arrangements with a sole proprietorship, a partnership or a corporation ("contractor") for the provision of a service to the government of Guam, and in such cases where the contractor employs a person(s) whose purpose, in whole or in part, is the direct delivery of service contracted by the government of Guam, then the contractor shall pay such employee(s) in accordance with the Wage Determination for Guam and the Northern Mariana Islands issued and promulgated by the U.S. Department of Labor for such labor as is employed in the direct delivery of contract deliverables to the government of Guam.

The Wage Determination most recently issued by the U.S. Department of Labor at the time a contract is awarded to a contractor by the government of Guam shall be used to determine wages, which shall be paid to employees pursuant to this Article. Should any contract contain a renewal clause, then at the time of renewal adjustments, there shall be made stipulations contained in that contract for applying the Wage Determination, as required by this Article, so that the Wage Determination promulgated by the U.S. Department of Labor on a date most recent to the renewal date shall apply.

§ 5802. Benefits.

In addition to the Wage Determination detailed in this Article, any contract to which this Article applies shall also contain provisions mandating health and similar benefits for employees covered by this Article, such benefits having a minimum value as detailed in the Wage Determination issued and promulgated by the U.S. Department of Labor, and shall contain provisions guaranteeing a minimum of ten (10) paid holidays per annum per employee.

(3) That the offeror is in full compliance with 5 GCA § 5801 and § 5802, as may be applicable to the procurement referenced herein;

(4) That I have attached the most recent wage determination applicable to Guam issued by the U.S. Department of Labor. [INSTRUCTIONS - Please attach!]

Signature

"REGISTER OF WAGE DETERMINATIONS UNDER
THE SERVICE CONTRACT ACT
By direction of the Secretary of Labor

U.S. DEPARTMENT OF LABOR
EMPLOYMENT STANDARDS ADMINISTRATION
WAGE AND HOUR DIVISION
WASHINGTON D.C. 20210

Daniel W. Simms
Director

Division of
Wage Determinations

Wage Determination No.: 2015-5693
Revision No.: 12
Date Of Last Revision: 12/21/2020

Note: Under Executive Order (EO) 13658 an hourly minimum wage of \$10.95 for calendar year 2021 applies to all contracts subject to the Service Contract Act for which the contract is awarded (and any solicitation was issued) on or after January 1 2015. If this contract is covered by the EO the contractor must pay all workers in any classification listed on this wage determination at least \$10.95 per hour (or the applicable wage rate listed on this wage determination if it is higher) for all hours spent performing on the contract in calendar year 2021. The EO minimum wage rate will be adjusted annually. Additional information on contractor requirements and worker protections under the EO is available at www.dol.gov/whd/govcontracts.

States: Guam Northern Marianas Wake Island

Area: Guam Statewide

Northern Marianas Statewide

Wake Island Statewide

Fringe Benefits Required Follow the Occupational Listing

OCCUPATION CODE * TITLE	FOOTNOTE	RATE
01000 - Administrative Support And Clerical Occupations		
01011 - Accounting Clerk I		13.57
01012 - Accounting Clerk II		15.23
01013 - Accounting Clerk III		17.04
01020 - Administrative Assistant		21.43
01035 - Court Reporter		17.40
01041 - Customer Service Representative I		11.51
01042 - Customer Service Representative II		12.94
01043 - Customer Service Representative III		14.12
01051 - Data Entry Operator I		12.15
01052 - Data Entry Operator II		13.25
01060 - Dispatcher Motor Vehicle		15.81

01070	- Document Preparation Clerk	13.85
01090	- Duplicating Machine Operator	13.85
01111	- General Clerk I	10.35
01112	- General Clerk II	11.29
01113	- General Clerk III	12.68
01120	- Housing Referral Assistant	19.39
01141	- Messenger Courier	11.37
01191	- Order Clerk I	12.57
01192	- Order Clerk II	13.71
01261	- Personnel Assistant (Employment) I	15.95
01262	- Personnel Assistant (Employment) II	17.85
01263	- Personnel Assistant (Employment) III	19.89
01270	- Production Control Clerk	21.78
01290	- Rental Clerk	11.10
01300	- Scheduler Maintenance	15.55
01311	- Secretary I	15.55
01312	- Secretary II	17.40
01313	- Secretary III	19.39
01320	- Service Order Dispatcher	14.00
01410	- Supply Technician	21.43
01420	- Survey Worker	16.79
01460	- Switchboard Operator/Receptionist	9.67
01531	- Travel Clerk I	13.01
01532	- Travel Clerk II	14.12
01533	- Travel Clerk III	15.09
01611	- Word Processor I	14.53
01612	- Word Processor II	16.31
01613	- Word Processor III	18.26
05000	- Automotive Service Occupations	
05005	- Automobile Body Repairer Fiberglass	14.82
05010	- Automotive Electrician	13.92
05040	- Automotive Glass Installer	13.02
05070	- Automotive Worker	13.02
05110	- Mobile Equipment Servicer	11.16
05130	- Motor Equipment Metal Mechanic	14.82
05160	- Motor Equipment Metal Worker	13.02
05190	- Motor Vehicle Mechanic	14.82
05220	- Motor Vehicle Mechanic Helper	10.22
05250	- Motor Vehicle Upholstery Worker	12.11
05280	- Motor Vehicle Wrecker	13.02
05310	- Painter Automotive	13.92
05340	- Radiator Repair Specialist	13.02
05370	- Tire Repairer	12.34
05400	- Transmission Repair Specialist	14.82
07000	- Food Preparation And Service Occupations	
07010	- Baker	10.47
07041	- Cook I	12.05
07042	- Cook II	14.05
07070	- Dishwasher	9.28
07130	- Food Service Worker	9.34

07210 - Meat Cutter	11.86
07260 - Waiter/Waitress	9.23
09000 - Furniture Maintenance And Repair Occupations	
09010 - Electrostatic Spray Painter	18.04
09040 - Furniture Handler	10.95
09080 - Furniture Refinisher	18.04
09090 - Furniture Refinisher Helper	13.27
09110 - Furniture Repairer Minor	15.70
09130 - Upholsterer	18.04
11000 - General Services And Support Occupations	
11030 - Cleaner Vehicles	9.35
11060 - Elevator Operator	9.35
11090 - Gardener	13.00
11122 - Housekeeping Aide	9.44
11150 - Janitor	9.44
11210 - Laborer Grounds Maintenance	9.82
11240 - Maid or Houseman	9.26
11260 - Pruner	8.79
11270 - Tractor Operator	11.90
11330 - Trail Maintenance Worker	9.82
11360 - Window Cleaner	10.54
12000 - Health Occupations	
12010 - Ambulance Driver	17.77
12011 - Breath Alcohol Technician	17.77
12012 - Certified Occupational Therapist Assistant	24.38
12015 - Certified Physical Therapist Assistant	24.38
12020 - Dental Assistant	15.02
12025 - Dental Hygienist	32.84
12030 - EKG Technician	25.99
12035 - Electroneurodiagnostic Technologist	25.99
12040 - Emergency Medical Technician	17.77
12071 - Licensed Practical Nurse I	15.88
12072 - Licensed Practical Nurse II	17.77
12073 - Licensed Practical Nurse III	19.81
12100 - Medical Assistant	12.26
12130 - Medical Laboratory Technician	18.82
12160 - Medical Record Clerk	13.61
12190 - Medical Record Technician	17.77
12195 - Medical Transcriptionist	15.88
12210 - Nuclear Medicine Technologist	39.04
12221 - Nursing Assistant I	11.34
12222 - Nursing Assistant II	12.75
12223 - Nursing Assistant III	13.91
12224 - Nursing Assistant IV	15.61
12235 - Optical Dispenser	17.77
12236 - Optical Technician	15.88
12250 - Pharmacy Technician	15.49
12280 - Phlebotomist	15.33
12305 - Radiologic Technologist	23.03
12311 - Registered Nurse I	22.53

12312 - Registered Nurse II	27.56
12313 - Registered Nurse II Specialist	27.56
12314 - Registered Nurse III	33.34
12315 - Registered Nurse III Anesthetist	33.34
12316 - Registered Nurse IV	39.96
12317 - Scheduler (Drug and Alcohol Testing)	22.01
12320 - Substance Abuse Treatment Counselor	22.01
13000 - Information And Arts Occupations	
13011 - Exhibits Specialist I	20.35
13012 - Exhibits Specialist II	25.20
13013 - Exhibits Specialist III	30.83
13041 - Illustrator I	20.35
13042 - Illustrator II	25.20
13043 - Illustrator III	30.83
13047 - Librarian	27.91
13050 - Library Aide/Clerk	16.20
13054 - Library Information Technology Systems Administrator	25.20
13058 - Library Technician	16.64
13061 - Media Specialist I	18.18
13062 - Media Specialist II	20.35
13063 - Media Specialist III	22.68
13071 - Photographer I	18.18
13072 - Photographer II	20.35
13073 - Photographer III	25.20
13074 - Photographer IV	30.83
13075 - Photographer V	37.30
13090 - Technical Order Library Clerk	20.35
13110 - Video Teleconference Technician	17.38
14000 - Information Technology Occupations	
14041 - Computer Operator I	15.71
14042 - Computer Operator II	17.22
14043 - Computer Operator III	19.19
14044 - Computer Operator IV	21.33
14045 - Computer Operator V	23.62
14071 - Computer Programmer I	(see 1) 15.73
14072 - Computer Programmer II	(see 1) 19.50
14073 - Computer Programmer III	(see 1) 23.84
14074 - Computer Programmer IV	(see 1)
14101 - Computer Systems Analyst I	(see 1) 24.23
14102 - Computer Systems Analyst II	(see 1)
14103 - Computer Systems Analyst III	(see 1)
14150 - Peripheral Equipment Operator	15.71
14160 - Personal Computer Support Technician	21.33
14170 - System Support Specialist	21.24
15000 - Instructional Occupations	
15010 - Aircrew Training Devices Instructor (Non-Rated)	24.23
15020 - Aircrew Training Devices Instructor (Rated)	29.32
15030 - Air Crew Training Devices Instructor (Pilot)	34.91
15050 - Computer Based Training Specialist / Instructor	24.23

15060 - Educational Technologist	27.61
15070 - Flight Instructor (Pilot)	34.91
15080 - Graphic Artist	20.47
15085 - Maintenance Test Pilot Fixed Jet/Prop	34.91
15086 - Maintenance Test Pilot Rotary Wing	34.91
15088 - Non-Maintenance Test/Co-Pilot	34.91
15090 - Technical Instructor	17.67
15095 - Technical Instructor/Course Developer	21.62
15110 - Test Proctor	14.27
15120 - Tutor	14.27
16000 - Laundry Dry-Cleaning Pressing And Related Occupations	
16010 - Assembler	9.88
16030 - Counter Attendant	9.88
16040 - Dry Cleaner	11.30
16070 - Finisher Flatwork Machine	9.88
16090 - Presser Hand	9.88
16110 - Presser Machine Drycleaning	9.88
16130 - Presser Machine Shirts	9.88
16160 - Presser Machine Wearing Apparel Laundry	9.88
16190 - Sewing Machine Operator	11.94
16220 - Tailor	12.44
16250 - Washer Machine	10.36
19000 - Machine Tool Operation And Repair Occupations	
19010 - Machine-Tool Operator (Tool Room)	18.04
19040 - Tool And Die Maker	22.67
21000 - Materials Handling And Packing Occupations	
21020 - Forklift Operator	13.96
21030 - Material Coordinator	21.78
21040 - Material Expediter	21.78
21050 - Material Handling Laborer	11.37
21071 - Order Filler	9.66
21080 - Production Line Worker (Food Processing)	13.96
21110 - Shipping Packer	15.92
21130 - Shipping/Receiving Clerk	15.92
21140 - Store Worker I	14.76
21150 - Stock Clerk	20.75
21210 - Tools And Parts Attendant	13.96
21410 - Warehouse Specialist	13.96
23000 - Mechanics And Maintenance And Repair Occupations	
23010 - Aerospace Structural Welder	22.76
23019 - Aircraft Logs and Records Technician	17.70
23021 - Aircraft Mechanic I	21.67
23022 - Aircraft Mechanic II	22.76
23023 - Aircraft Mechanic III	23.91
23040 - Aircraft Mechanic Helper	15.07
23050 - Aircraft Painter	20.35
23060 - Aircraft Servicer	17.70
23070 - Aircraft Survival Flight Equipment Technician	20.35
23080 - Aircraft Worker	19.12
23091 - Aircrew Life Support Equipment (ALSE) Mechanic	19.12

I		
23092	- Aircrew Life Support Equipment (ALSE) Mechanic	21.67
II		
23110	- Appliance Mechanic	18.04
23120	- Bicycle Repairer	14.49
23125	- Cable Splicer	19.59
23130	- Carpenter Maintenance	16.07
23140	- Carpet Layer	16.86
23160	- Electrician Maintenance	18.05
23181	- Electronics Technician Maintenance I	16.86
23182	- Electronics Technician Maintenance II	18.04
23183	- Electronics Technician Maintenance III	19.55
23260	- Fabric Worker	15.70
23290	- Fire Alarm System Mechanic	15.43
23310	- Fire Extinguisher Repairer	14.49
23311	- Fuel Distribution System Mechanic	19.21
23312	- Fuel Distribution System Operator	14.49
23370	- General Maintenance Worker	11.96
23380	- Ground Support Equipment Mechanic	21.67
23381	- Ground Support Equipment Servicer	17.70
23382	- Ground Support Equipment Worker	19.12
23391	- Gunsmith I	14.49
23392	- Gunsmith II	16.86
23393	- Gunsmith III	19.21
23410	- Heating Ventilation And Air-Conditioning Mechanic	17.16
23411	- Heating Ventilation And Air Contidioning Mechanic (Research Facility)	18.25
23430	- Heavy Equipment Mechanic	18.35
23440	- Heavy Equipment Operator	17.12
23460	- Instrument Mechanic	19.21
23465	- Laboratory/Shelter Mechanic	18.04
23470	- Laborer	11.37
23510	- Locksmith	18.04
23530	- Machinery Maintenance Mechanic	23.13
23550	- Machinist Maintenance	19.21
23580	- Maintenance Trades Helper	10.67
23591	- Metrology Technician I	19.21
23592	- Metrology Technician II	20.42
23593	- Metrology Technician III	21.63
23640	- Millwright	19.21
23710	- Office Appliance Repairer	18.04
23760	- Painter Maintenance	13.95
23790	- Pipefitter Maintenance	18.39
23810	- Plumber Maintenance	17.27
23820	- Pneudraulic Systems Mechanic	19.21
23850	- Rigger	19.21
23870	- Scale Mechanic	16.86
23890	- Sheet-Metal Worker Maintenance	16.09
23910	- Small Engine Mechanic	16.86

23931 - Telecommunications Mechanic I	19.81
23932 - Telecommunications Mechanic II	19.91
23950 - Telephone Lineman	18.24
23960 - Welder Combination Maintenance	17.95
23965 - Well Driller	19.21
23970 - Woodcraft Worker	19.21
23980 - Woodworker	14.49
24000 - Personal Needs Occupations	
24550 - Case Manager	14.72
24570 - Child Care Attendant	10.09
24580 - Child Care Center Clerk	13.25
24610 - Chore Aide	11.62
24620 - Family Readiness And Support Services Coordinator	14.72
24630 - Homemaker	16.12
25000 - Plant And System Operations Occupations	
25010 - Boiler Tender	19.21
25040 - Sewage Plant Operator	21.59
25070 - Stationary Engineer	19.21
25190 - Ventilation Equipment Tender	13.27
25210 - Water Treatment Plant Operator	21.59
27000 - Protective Service Occupations	
27004 - Alarm Monitor	10.90
27007 - Baggage Inspector	9.40
27008 - Corrections Officer	12.05
27010 - Court Security Officer	12.05
27030 - Detection Dog Handler	10.90
27040 - Detention Officer	12.05
27070 - Firefighter	12.05
27101 - Guard I	9.40
27102 - Guard II	10.90
27131 - Police Officer I	12.05
27132 - Police Officer II	13.40
28000 - Recreation Occupations	
28041 - Carnival Equipment Operator	12.79
28042 - Carnival Equipment Repairer	13.97
28043 - Carnival Worker	9.45
28210 - Gate Attendant/Gate Tender	13.18
28310 - Lifeguard	11.01
28350 - Park Attendant (Aide)	14.74
28510 - Recreation Aide/Health Facility Attendant	11.84
28515 - Recreation Specialist	18.26
28630 - Sports Official	11.74
28690 - Swimming Pool Operator	17.71
29000 - Stevedoring/Longshoremen Occupational Services	
29010 - Blocker And Bracer	23.62
29020 - Hatch Tender	23.62
29030 - Line Handler	23.62
29041 - Stevedore I	21.98
29042 - Stevedore II	25.26

30000	- Technical Occupations	
30010	- Air Traffic Control Specialist Center (HFO) (see 2)	39.89
30011	- Air Traffic Control Specialist Station (HFO) (see 2)	27.50
30012	- Air Traffic Control Specialist Terminal (HFO) (see 2)	30.29
30021	- Archeological Technician I	17.49
30022	- Archeological Technician II	19.56
30023	- Archeological Technician III	24.21
30030	- Cartographic Technician	23.18
30040	- Civil Engineering Technician	23.08
30051	- Cryogenic Technician I	25.57
30052	- Cryogenic Technician II	28.24
30061	- Drafter/CAD Operator I	17.49
30062	- Drafter/CAD Operator II	19.56
30063	- Drafter/CAD Operator III	20.77
30064	- Drafter/CAD Operator IV	25.57
30081	- Engineering Technician I	14.84
30082	- Engineering Technician II	16.66
30083	- Engineering Technician III	18.64
30084	- Engineering Technician IV	23.08
30085	- Engineering Technician V	28.24
30086	- Engineering Technician VI	34.16
30090	- Environmental Technician	23.08
30095	- Evidence Control Specialist	23.08
30210	- Laboratory Technician	20.77
30221	- Latent Fingerprint Technician I	25.57
30222	- Latent Fingerprint Technician II	28.24
30240	- Mathematical Technician	23.34
30361	- Paralegal/Legal Assistant I	19.44
30362	- Paralegal/Legal Assistant II	23.94
30363	- Paralegal/Legal Assistant III	29.29
30364	- Paralegal/Legal Assistant IV	35.44
30375	- Petroleum Supply Specialist	28.24
30390	- Photo-Optics Technician	21.93
30395	- Radiation Control Technician	28.24
30461	- Technical Writer I	23.08
30462	- Technical Writer II	28.24
30463	- Technical Writer III	34.16
30491	- Unexploded Ordnance (UXO) Technician I	25.35
30492	- Unexploded Ordnance (UXO) Technician II	30.67
30493	- Unexploded Ordnance (UXO) Technician III	36.76
30494	- Unexploded (UXO) Safety Escort	25.35
30495	- Unexploded (UXO) Sweep Personnel	25.35
30501	- Weather Forecaster I	25.57
30502	- Weather Forecaster II	31.09
30620	- Weather Observer Combined Upper Air Or Surface Programs	(see 2) 20.77
30621	- Weather Observer Senior	(see 2) 23.08
31000	- Transportation/Mobile Equipment Operation Occupations	
31010	- Airplane Pilot	30.67
31020	- Bus Aide	8.15

31030 - Bus Driver	9.69
31043 - Driver Courier	9.69
31260 - Parking and Lot Attendant	9.91
31290 - Shuttle Bus Driver	10.59
31310 - Taxi Driver	10.37
31361 - Truckdriver Light	10.59
31362 - Truckdriver Medium	11.61
31363 - Truckdriver Heavy	13.92
31364 - Truckdriver Tractor-Trailer	13.92
99000 - Miscellaneous Occupations	
99020 - Cabin Safety Specialist	14.95
99030 - Cashier	9.48
99050 - Desk Clerk	9.70
99095 - Embalmer	25.35
99130 - Flight Follower	25.35
99251 - Laboratory Animal Caretaker I	22.67
99252 - Laboratory Animal Caretaker II	24.77
99260 - Marketing Analyst	21.54
99310 - Mortician	25.35
99410 - Pest Controller	14.61
99510 - Photofinishing Worker	13.32
99710 - Recycling Laborer	15.75
99711 - Recycling Specialist	21.66
99730 - Refuse Collector	14.91
99810 - Sales Clerk	9.66
99820 - School Crossing Guard	16.75
99830 - Survey Party Chief	22.02
99831 - Surveying Aide	12.52
99832 - Surveying Technician	16.27
99840 - Vending Machine Attendant	22.67
99841 - Vending Machine Repairer	28.88
99842 - Vending Machine Repairer Helper	22.67

Note: Executive Order (EO) 13706 Establishing Paid Sick Leave for Federal Contractors applies to all contracts subject to the Service Contract Act for which the contract is awarded (and any solicitation was issued) on or after January 1 2017. If this contract is covered by the EO the contractor must provide employees with 1 hour of paid sick leave for every 30 hours they work up to 56 hours of paid sick leave each year. Employees must be permitted to use paid sick leave for their own illness injury or other health-related needs including preventive care; to assist a family member (or person who is like family to the employee) who is ill.

injured or has other health-related needs including preventive care; or for reasons resulting from or to assist a family member (or person who is like family to the employee) who is the victim of domestic violence sexual assault or stalking. Additional information on contractor requirements and worker protections under the EO is available at www.dol.gov/whd/govcontracts.

ALL OCCUPATIONS LISTED ABOVE RECEIVE THE FOLLOWING BENEFITS:

HEALTH & WELFARE: \$4.54 per hour up to 40 hours per week or \$181.60 per week or \$786.93 per month

HEALTH & WELFARE EO 13706: \$4.22 per hour up to 40 hours per week or \$168.80 per week or \$731.47 per month*

*This rate is to be used only when compensating employees for performance on an SCA-covered contract also covered by EO 13706 Establishing Paid Sick Leave for Federal Contractors. A contractor may not receive credit toward its SCA obligations for any paid sick leave provided pursuant to EO 13706.

VACATION: 2 weeks paid vacation after 1 year of service with a contractor or successor; and 4 weeks after 3 years. Length of service includes the whole span of continuous service with the present contractor or successor wherever employed and with the predecessor contractors in the performance of similar work at the same Federal facility. (Reg. 29 CFR 4.173)

HOLIDAYS: A minimum of ten paid holidays per year: New Year's Day Martin Luther King Jr.'s Birthday Washington's Birthday Memorial Day Independence Day Labor Day Columbus Day Veterans' Day Thanksgiving Day and Christmas Day. (A contractor may substitute for any of the named holidays another day off with pay in accordance with a plan communicated to the employees involved.) (See 29 CFR 4.174)

THE OCCUPATIONS WHICH HAVE NUMBERED FOOTNOTES IN PARENTHESES RECEIVE THE FOLLOWING:

1) COMPUTER EMPLOYEES: Under the SCA at section 8(b) this wage determination does not apply to any employee who individually qualifies as a bona fide executive administrative or professional employee as defined in 29 C.F.R. Part 541. Because most Computer System Analysts and Computer Programmers who are compensated at a rate

not less than \$27.63 (or on a salary or fee basis at a rate not less than \$455 per week) an hour would likely qualify as exempt computer professionals (29 C.F.R. 541.400) wage rates may not be listed on this wage determination for all occupations within those job families. In addition because this wage determination may not list a wage rate for some or all occupations within those job families if the survey

data indicates that the prevailing wage rate for the occupation equals or exceeds \$27.63 per hour conformances may be necessary for certain nonexempt employees. For example if an individual employee is nonexempt but nevertheless performs duties within the scope of one of the Computer Systems Analyst or Computer Programmer occupations for which this wage determination does not specify an SCA wage rate then the wage rate for that employee must be conformed in accordance with the conformance procedures described in the conformance note included on this wage determination.

Additionally because job titles vary widely and change quickly in the computer industry job titles are not determinative of the application of the computer professional exemption. Therefore the exemption applies only to computer employees who satisfy the compensation requirements and whose primary duty consists of:

(1) The application of systems analysis techniques and procedures including consulting with users to determine hardware software or system functional specifications;

(2) The design development documentation analysis creation testing or modification of computer systems or programs including prototypes based on and related to user or system design specifications;

(3) The design documentation testing creation or modification of computer programs related to machine operating systems; or

(4) A combination of the aforementioned duties the performance of which requires the same level of skills. (29 C.F.R. 541.400).

2) AIR TRAFFIC CONTROLLERS AND WEATHER OBSERVERS - NIGHT PAY & SUNDAY PAY: If you work at night as part of a regular tour of duty you will earn a night differential and receive an additional 10% of basic pay for any hours worked between 6pm and 6am.

If you are a full-time employed (40 hours a week) and Sunday is part of your regularly scheduled workweek you are paid at your rate of basic pay plus a Sunday premium of 25% of your basic rate for each hour of Sunday work which is not overtime

(i.e. occasional work on Sunday outside the normal tour of duty is considered overtime work).

**** HAZARDOUS PAY DIFFERENTIAL ****

An 8 percent differential is applicable to employees employed in a position that represents a high degree of hazard when working with or in close proximity to ordnance explosives and incendiary materials. This includes work such as screening blending dying mixing and pressing of sensitive ordnance explosives and pyrotechnic compositions such as lead azide black powder and photoflash powder.

All dry-house activities involving propellants or explosives. Demilitarization modification renovation demolition and maintenance operations on sensitive ordnance explosives and incendiary materials. All operations involving re-grading and cleaning of artillery ranges.

A 4 percent differential is applicable to employees employed in a position that represents a low degree of hazard when working with or in close proximity to ordnance (or employees possibly adjacent to) explosives and incendiary materials which involves potential injury such as laceration of hands face or arms of the employee engaged in the operation irritation of the skin minor burns and the like; minimal damage to immediate or adjacent work area or equipment being used. All operations involving unloading storage and hauling of ordnance explosive and incendiary ordnance material other than small arms ammunition. These differentials are only applicable to work that has been specifically designated by the agency for ordnance explosives and incendiary material differential pay.

**** UNIFORM ALLOWANCE ****

If employees are required to wear uniforms in the performance of this contract (either by the terms of the Government contract by the employer by the state or local law etc.) the cost of furnishing such uniforms and maintaining (by laundering or dry cleaning) such uniforms is an expense that may not be borne by an employee where such cost reduces the hourly rate below that required by the wage

determination. The Department of Labor will accept payment in accordance with the following standards as compliance:

The contractor or subcontractor is required to furnish all employees with an adequate number of uniforms without cost or to reimburse employees for the actual cost of the uniforms. In addition where uniform cleaning and maintenance is made the responsibility of the employee all contractors and subcontractors subject to this wage determination shall (in the absence of a bona fide collective bargaining agreement providing for a different amount or the furnishing of contrary affirmative proof as to the actual cost) reimburse all employees for such cleaning and maintenance at a rate of \$3.35 per week (or \$.67 cents per day). However in those instances where the uniforms furnished are made of "wash and wear" materials may be routinely washed and dried with other personal garments and do not require any special treatment such as dry cleaning daily washing or commercial laundering in order to meet the cleanliness or appearance standards set by the terms

of the Government contract by the contractor by law or by the nature of the work there is no requirement that employees be reimbursed for uniform maintenance costs.

**** SERVICE CONTRACT ACT DIRECTORY OF OCCUPATIONS ****

The duties of employees under job titles listed are those described in the "Service Contract Act Directory of Occupations" Fifth Edition (Revision 1) dated September 2015 unless otherwise indicated.

**** REQUEST FOR AUTHORIZATION OF ADDITIONAL CLASSIFICATION AND WAGE RATE Standard Form 1444 (SF-1444) ****

Conformance Process:

The contracting officer shall require that any class of service employee which is not listed herein and which is to be employed under the contract (i.e. the work to be performed is not performed by any classification listed in the wage determination) be classified by the contractor so as to provide a reasonable relationship (i.e. appropriate level of skill comparison) between such unlisted classifications and the classifications listed in the wage determination (See 29 CFR

4.6(b)(2)(i)). Such conforming procedures shall be initiated by the contractor

prior to the performance of contract work by such unlisted class(es) of employees (See 29 CFR 4.6(b)(2)(ii)). The Wage and Hour Division shall make a final determination of conformed classification wage rate and/or fringe benefits which shall be paid to all employees performing in the classification from the first day of work on which contract work is performed by them in the classification. Failure to pay such unlisted employees the compensation agreed upon by the interested parties and/or fully determined by the Wage and Hour Division retroactive to the date such class of employees commenced contract work shall be a violation of the Act

and this contract. (See 29 CFR 4.6(b)(2)(v)). When multiple wage determinations are included in a contract a separate SF-1444 should be prepared for each wage determination to which a class(es) is to be conformed.

The process for preparing a conformance request is as follows:

- 1) When preparing the bid the contractor identifies the need for a conformed occupation(s) and computes a proposed rate(s).

- 2) After contract award the contractor prepares a written report listing in order the proposed classification title(s) a Federal grade equivalency (FGE) for each proposed classification(s) job description(s) and rationale for proposed wage rate(s) including information regarding the agreement or disagreement of the authorized representative of the employees involved or where there is no authorized representative the employees themselves. This report should be submitted to the contracting officer no later than 30 days after such unlisted class(es) of employees performs any contract work.

- 3) The contracting officer reviews the proposed action and promptly submits a report of the action together with the agency's recommendations and pertinent information including the position of the contractor and the employees to the U.S. Department of Labor Wage and Hour Division for review (See 29 CFR 4.6(b)(2)(ii)),

- 4) Within 30 days of receipt the Wage and Hour Division approves modifies or disapproves the action via transmittal to the agency contracting officer or notifies the contracting officer that additional time will be required to process the request.

5) The contracting officer transmits the Wage and Hour Division's decision to the contractor.

6) Each affected employee shall be furnished by the contractor with a written copy of such determination or it shall be posted as a part of the wage determination (See

29 CFR 4.6(b)(2)(iii)).

Information required by the Regulations must be submitted on SF-1444 or bond paper.

When preparing a conformance request the "Service Contract Act Directory of Occupations" should be used to compare job definitions to ensure that duties requested are not performed by a classification already listed in the wage determination. Remember it is not the job title but the required tasks that determine whether a class is included in an established wage determination. Conformances may not be used to artificially split combine or subdivide classifications listed in the wage determination (See 29 CFR 4.152(c)(1))."



P.O BOX 12577 TAMUNING, GUAM 96931
Tel. (671) 646-8842 Fax. (671) 646-8843
E-mail: admin@clayarchinc.com
Website: www.clayarchinc.com

WARRANTY CERTIFICATE

WARRANTY FOR;

Project: **GCC-FB-21-009 Replacement of Building 900 Metal Awning Structure**
Owner: **Guam Community College**
Location: **#1 Sesame Street, Mangilao, Guam 96913**
Contractor: **Clayarch, Inc.**

I, the undersigned, do hereby warrant that all labor and materials furnished and work performed in conjunction with the above referenced project are in compliance with the Contract Documents and authorized modifications thereto, and will be free from defects due to defective materials or workmanship for a period of **ONE (1) YEAR** or a time as specified from the Date of Turnover.

This Warranty commences on _____ and expires on _____.

Should any defects develop during the warranty period due to improper materials, workmanship or arrangement, the defect, including adjacent work displaced, shall be made good by the undersigned at no expense to the Owner.

Written notice of defective work will be given to the undersigned. Should we fail to correct defective work within a reasonable time after receiving written notice, the Owner may, at his option correct defects and charge the undersigned costs for such correction. The undersigned agrees to pay such charges upon demand.

Nothing in the above shall be deemed to apply to work which has been abused or neglected by the Owner or for any reasons by acts of God.

A handwritten signature in black ink, appearing to read 'Min Chul Kong', is written over a horizontal line.

MIN CHUL KONG
VICE PRESIDENT

GCC PR0213

2021

CONTRACTOR'S LICENSE

LOU LEON GUERRERO
Governor of Guam

JOSH TENORIO
Lt. Governor of Guam

Pursuant to the provisions of Chapter VII Title XI of the Government of Guam and the Rules and Regulations of the Contractors License Board, the Executive Director of Contractors hereby issues this license to:

Clayarch, Inc.

To engage in the business or act in the capacity of a contractor in the following classifications

A,B,C13,C13A,C14,C19,C20 & C25

This license is the property of the Executive Director of Contractors, not transferable, and shall be returned to the Executive Director upon demand when suspended, revoked, or invalidated for any reason. It becomes void if not renewed on or before the expiration date.

Signature of RME
RME #

Signature of LICENSEE
License # CLB10-0634

GRT # 201000924
Issued: June 16, 2020

Certificate # C-0620-0246
Expires: June 30, 2021

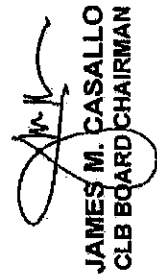
JAMES M. CASALLO
CLB BOARD CHAIRMAN



CECIL "BUDDY" L. ORSINI
EXECUTIVE DIRECTOR

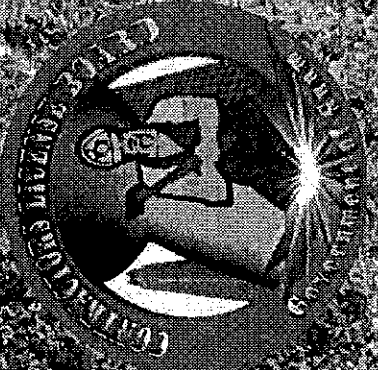

GUAM COMMUNITY COLLEGE

PRE-BID CONFERENCE NOTES

Bid No.: GCC-FB-21-009

Bid Description: Replacement of Building 900 Metal Awning Structure

Attendance:

Guam Community College: Joleen Evangelista (MMO), Patricia Palacios (MMO), Francisco Palacios (P&D), Inocencio San Agustin (P&D)

Vendors:

ClayArch Inc.; Hak Jung Kim, Min-Chul Kong, Paradise Awning; Alex Au-Yeaung, Top Builders, LLC; Edwin Aclan, JJ Global Services; Aaron Burger, Jerome Usan, Craig Usan

Meeting called to order by Joleen Evangelista, MMO @ 10:00 a.m. Introductions conducted.

Procurement Requirements: This is the Mandatory Pre-Bid Conference & Site Visit for GCC-FB-21-009-- Prospective Bidders must be in present attendance at the pre-bid conference and pay the \$25.00 fee by 4:00 pm today, in order to qualify for the bid. Prospective bidder must submit an original and two copies of the bid in a sealed envelope and can be submitted prior to 10:00 a.m., Thursday, June 3, 2021. No Late Bids are accepted. Bid Packets must be dated and stamp by Materials Management Office. Any questions asked must be in writing and submitted to materialsmanagement@guamcc.edu no later than Thursday, May 20, 2021, 5:00 p.m. Also, acknowledgement of receipt of the amendment is required via email or fax. If you send the questions by fax please call MMO to ensure we received the questions. Please acknowledge indicating your company name & contact person, address & Amendment number on the email. The deadline for GCC to response to the questions is Tuesday, May 25, 2021 by 5:00pm. Required delivery date is 90 Calendar Days upon receipt of the purchase order/contract to include building permit process and material lead time.

A Bid Guarantee (15% of bid amount) is required it may be in a form of a Cashier's check, letter of credit, surety bond with the certificate of authority, & power of attorney. Brochures/Descriptive Literature/Technical Specifications, Project Narrative, CPM Chart, Conceptual Design. A performance bond is required for this bid. Affidavit Disclosing Ownership and Commissions; Other Affidavits: Non-Collusion, Gratuities and Kickbacks, Ethical Standards and Contingent Fees, all affidavits must be notarized. U. S. Department of Labor Wage Determination (please see instructions in the form however, GCC provided the wage listing in the Bid Packet that must be submitted with the DOL wage form. Also attached to the bid packet is the Government of Guam Holidays, GCC Campus Map and the 5 Year Academic Calendar. Prospective Bidders must acknowledge pre-bid minutes and any Addendums issued by the GCC Materials Management Office; Upon bid award the successful bidder must provide a current Guam Business License expiring 2021 or 2022. All documents required in the bid must be submitted. Failure to comply with the requirements will be basis of non-selection/disqualification and rejection of the bid. Testing on the structure was done and came back negative, no asbestos or lead found.

Scope of Work Requirements: Guam Community College (GCC) is soliciting the service of a qualified contractor to replace the dilapidated awning structure located at building 900.

Questions:

1. Does GCC need two prices for Galvanize Steel? – JJ Global Services - Yes, you need a price for Option 1 and Option 2-two separate line items.

> 5:00 p.m., Thursday, May 20, 2021 - Deadline for Questions

> 5:00 p.m., Tuesday, May 25, 2021 - Deadline for GCC Response to Questions

> 10:00 a.m., Thursday, June 3, 2021 - Bid Opening. Bidders may submit packages a day before to avoid rushing. No late bids will be accepted. Bidders are welcome but not a requirement to attend the bid opening; however, your bid packet must be submitted before this time. No late packets will be accepted. Today at 4:00pm is the deadline to purchase a bid packet.

Meeting adjourned: 10:22 a.m.

Transcribed by: *Patricia U. Palacios, MMO*

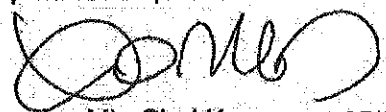

Min Chul Kong 05/20/2021
Clayarch, Inc.
P.O.Box 12577
Tamuning, Guam 96931

GCC PR0216

BID PRICE SHEET



BID NO.: GCC-FB-21-009

Replacement of Building 900 Metal Awning Structure

Date: June 3, 2021

SOW Description	Cost for Supplies, Materials, etc.	Cost for Labor	Total	
			Option 1 (Black Iron)	Option 2 (Galvanized)
a. Removal and Disposal of the existing awning. (i.e. Corrugated roof sheet panels, purlins, rafters, etc.)		\$9,640.00	\$9,640.00	\$9,640.00
b. Removal and disposal of the existing metal columns and beams		\$10,250.00	\$10,250.00	\$10,250.00
c. Installation of new metal columns and beams (Option 1 for Black Iron) (Option 2 for Galvanized)	\$34,240.00 \$43,240.00	\$24,320.00	\$58,560.00	\$67,560.00
d. Installation of cable bracing at three (3) specific locations	\$6,560.00	\$4,100.00	\$10,660.00	\$10,660.00
e. Installation of new perlin S-layer and 2'-6" overlap including all component elements.	\$16,580.00	\$11,890.00	\$27,470.00	\$27,470.00
f. Installation of new rafter system including all component elements	\$8,580.00	\$8,610.00	\$15,170.00	\$15,170.00
g. Installation of 22 gauge thickness corrugated roof sheet panels to include roof sealant for fastener and joint protection and leak prevention.	\$21,320.00	\$16,200.00	\$37,520.00	\$37,520.00
h. Application of awning / roofing sealant for fastener and joint protection and leak prevention	\$2,050.00	\$2,050.00	\$4,100.00	\$4,100.00
i. Removal and reinstallation of additional tools, equipment, infrastructure, etc; into the new awning structure.	\$2,460.00	\$7,170.00	\$9,630.00	\$9,630.00
Total Project Bid Price			\$183,000.00	\$192,000.00

Option 1

Option 2

 MIN CHUL KONG
 VICE PRESIDENT