



Jerrick Hernandez <jhernandez@guamopa.com>

OPA-PA-002-24 Third Supplement to Procurement Record

Jessica L. Toft <jtoft@portofguam.com>

Tue, Sep 17, 2024 at 4:19 PM

To: Jerrick Hernandez <jhernandez@guamopa.com>

Cc: "Kiana M. Santos" <kmsantos@portofguam.com>, jdwalsh <jdwalsh@rwtguam.com>, jrazzano <jrazzano@rwtguam.com>, eservice <eservice@rwtguam.com>, msaldana <msaldana@rwtguam.com>

Hello Jerrick,

Please accept the attached Third Supplement to Record Documents, Third Supplement to Record Documents Table of Contents, and Documents 2c, 4c, 6c, and 6d, for filing in OPA-PA-024-002. Thank you again!









Jessica Toft
Port Staff Attorney
Port Authority of Guam
1026 Cabras Highway, Ste. 201
Piti, Guam 96925
Tel: (671) 472-1054
Fax: (671) 477-4445
Email: jtoft@portofguam.com
Website: www.portofguam.com

*** CONFIDENTIALITY NOTICE ****

This email and any files transmitted with it are confidential and intended solely for the use of the individual or entity to whom they are addressed. If you have received this email in error, please notify the system manager. This message contains confidential information and is intended only for the individual named. If you are not the named addressee you should not disseminate, distribute or copy this e-mail. Please notify the sender immediately by e-mail if you have received this e-mail by mistake and delete this e-mail from your system. If you are not the intended recipient you are notified that disclosing, copying, distributing or taking any action in reliance on the contents of this information is strictly prohibited.

6 attachments

-  **6d - Signed Bid Contracting Documents (IFB-PAG-013-24).pdf**
1743K
-  **6c - Purchase Order (IFB-PAG-013-24).pdf**
976K
-  **4c - BID ANALYSIS (IFB-PAG-013-24).pdf**
107K
-  **2c - Registration and Distribution of IFB (IFB-PAG-013-24).pdf**
230K
-  **Third Supplement to Record Documents TOC.pdf**
67K
-  **Third Supplement to Procurement Record (signed).pdf**
36K

1 Jessica Toft
2 PORT AUTHORITY OF GUAM
3 *Aturidat I Puetton Guahan*
4 1026 Cabras Highway
5 Suite 201
6 Piti, Guam 96925
7 Tel. (671) 475-5931/35
8 Fax. (671) 477-2689/4445
9 jtoft@portofguam.com

7 **IN THE OFFICE OF PUBLIC ACCOUNTABILITY**
8 **PROCUREMENT APPEAL**

9 **IN THE APPEAL OF:**)
10)
11 **MORRICO EQUIPMENT, LLC,**)
12)
13 **Appellant,**)
14 **and**)
15 **PORT AUTHORITY OF GUAM,**)
16 **Purchasing Agency.**)

DOCKET NO. OPA-PA-24-002

THIRD
SUPPLEMENT TO RECORD
DOCUMENTS

17 Pursuant to 2 GAR, Div. 4 § 12104(c)(3), the Port Authority of Guam hereby submits
18 additional records as contained in the accompanying Table of Contents and attachments. These
19 documents are part of the Procurement Record in IFB-PAG-013-24, re: Re-bid Procurement of
20 180' Telescopic Boom Lift ("IFB #2"). These documents were inadvertently omitted from the
21 electronic Procurement Record filed on August 22, 2024.

22
23 Submitted this 17th day of September, 2024.

24 PORT AUTHORITY OF GUAM

25
26 By: 

JESSICA TOFT

THIRD SUPPLEMENT TO RECORD DOCUMENTS

TABLE OF CONTENTS

RE-BID - IFB-PAG-013-024 180' Telescopic Boom Lift

- **TAB 2a - Registration and Distribution of IFB (IFB-PAG-013-24);**
- **TAB 4a - Bid Analysis (IFB-PAG-013-24);**
- **TAB 6c - Signed Bid Contracting Documents (IFB-PAG-013-24); and**
- **Tab 6d - Purchase Order (IFB-PAG-013-24).**

2c



INVITATION FOR BID No.: IFB-PAG-013-24

RE-BID 180' TELESCOPIC BOOM LIFT

Pre-Bid Conference N/A Time: N/A		Q&C Deadline: Friday, April 8, 2024 Time: 5:00 p.m.		
		Bid Submittal: Monday, April 15 2024 Time: 2:00PM		
Company Name/ Phone/Fax	Business Address / Email address	Contact Full Name (Print)/ Date/ Time	Web DL	BID SUBMITTAL Received by / Date / Time
1 COMPANY NAME: MCKELCO EQUIPMENT PHONE: 671-649-1946 / 688-0309 FAX: N/A	ADDRESS: 197 YARD ROAD TAMUNING ISLAND 96913 EMAIL: SALES@MORRICOEQUIPMENT.COM	NAME: PATRICK M. CHARGEMALAF DATE: APRIL 24, 2024 TIME: 10:18 AM	X	PROCUREMENT INITIAL: <i>PM</i> DATE: MAY 8, 2024 TIME: 10:25 AM
2 COMPANY NAME: McKelco Federal Contract Corporation PHONE: 813-631-0500 FAX:	ADDRESS: 12918 N. Nebraska Ave. Tampa, FL 33612 EMAIL: pete@federalcontractcorp.com	NAME: Pete Pierson DATE: TIME:		PROCUREMENT INITIAL: <i>mpc</i> DATE: May 7, 2024 TIME: 11:22 pm
3 COMPANY NAME: PHONE: FAX:	ADDRESS: EMAIL:	NAME: DATE: TIME:		PROCUREMENT INITIAL: DATE: TIME:
4 COMPANY NAME: PHONE: FAX:	ADDRESS: EMAIL:	NAME: DATE: TIME:		PROCUREMENT INITIAL: DATE: TIME:
5 COMPANY NAME: PHONE: FAX:	ADDRESS: EMAIL:	NAME: DATE: TIME:		PROCUREMENT INITIAL: DATE: TIME:
6 COMPANY NAME: PHONE: FAX:	ADDRESS: EMAIL:	NAME: DATE: TIME:		PROCUREMENT INITIAL: DATE: TIME:
7 COMPANY NAME: PHONE: FAX:	ADDRESS: EMAIL:	NAME: DATE: TIME:		PROCUREMENT INITIAL: DATE: TIME:
8 COMPANY NAME: PHONE: FAX:	ADDRESS: EMAIL:	NAME: DATE: TIME:		PROCUREMENT INITIAL: DATE: TIME:

INVITATION FOR BID NO.: IFB-PAG-013-24

Re-bid 180' Telescopic Boom Lift

ACKNOWLEDGEMENT RECEIPT FORM

Please be advised that to be considered a prospective bidder you must fill out this Acknowledgement receipt form. Please submit by fax form to **(671) 472-1439** or email to **macabrera@portofguam.com**, and **papprocurement@portofguam.com**

Acknowledgement Receipt Form must be submitted no later than three (3) days upon receipt of IFB package.

Name	Patrick Mafnas Chargualaf
Signature	<small>Digitally signed by Patrick Mafnas Chargualaf DN: cn=Patrick Mafnas Chargualaf, o=Morrice Equipment LLC, ou=Generator and Equipment Sales, email=patrick@morriceequipment.com, c=GU Date: 2024.04.24 10:21:48 +10'00'</small>
Date	24 April 2024
Time	10:18 AM
Contact Number	(671) 649-1946 / 688-0309
Fax Number	N/A
Contact Person regarding IFB	Patrick Mafnas Chargualaf
Title	Generator & Equipment Sales
E-Mail Address	sales@morriceequipment.com
Company/Firm	Morrice Equipment
Address	197 Ypao Road, Tamuning, Guam 96913

Note: IFB recommends that prospective bidders register current contact information with IFB to ensure they receive any notices regarding any changes or update to the IFB. The procuring agency and IFB will not be liable for failure to provide notice to any party who did not register current contact information.

All questions and concerns in regards to this bid must be submitted to the PORT AUTHORITY OF GUAM via fax or email, addressed to the GENERAL MANAGER no later than **Wednesday, May 1, 2024** by the close of business at 5:00pm. Your inquiry may be sent by fax to (671)472-1439, or emailed to **rjrespicio@portofguam.com** and copied to **papprocurement@portofguam.com**, **algsablan@portofguam.com**, and **macabrera@portofguam.com**.

No Entitlement to Preparation Costs – the bidder expressly waives any right it may have against the government for any expenses incurred in connection with the preparation of its bid.

Re: Re-Bid for 180' Telescopic Boom Lift for the Port Authority of Guam

From : Mark A. Cabrera <macabrera@portofguam.com>
Subject : Re: Re-Bid for 180' Telescopic Boom Lift for the Port Authority of Guam

Wed, Apr 24, 2024 02:34 PM

📎 3 attachments

To : Patrick Chargualaf <Patrick@morricequipment.com>
Cc : PAG Procurement <pagprocurement@portofguam.com>, Jesse Munoz <Jesse.Munoz@morricequipment.com>, Joel Lesh <Joel.Lesh@MorricoEquipment.com>

Hello Mr. Chargualaf-

Your acknowledgement and registration have been received.

Thank You,

Mark A. Cabrera
Procurement Buyer Supervisor



Port Authority of Guam
1026 Cabras Highway
Suite 201 Piti GU 96915
(671)477-5931 ext. 252
macabrera@portofguam.com

From: "Patrick Chargualaf" <Patrick@morricequipment.com>
To: "Mark A. Cabrera" <macabrera@portofguam.com>, "PAG Procurement" <pagprocurement@portofguam.com>
Cc: "Jesse Munoz" <Jesse.Munoz@morricequipment.com>, "Joel Lesh" <Joel.Lesh@MorricoEquipment.com>
Sent: Wednesday, April 24, 2024 10:24:14 AM
Subject: Re: Re-Bid for 180' Telescopic Boom Lift for the Port Authority of Guam

Mark, et al,

Good morning.

Attached for your record,

Morrigo Equipment's Acknowledgement Receipt Form signed and dated for
IFB-PAG-013-24 Re-bid 180' Telescopic Boom Lift.

Please confirm receipt and kindly reply with any questions or concerns.

Patrick Mafnas Chargualaf
Generator And Equipment Sales
Office: 671.649.1946
Mobile: 671.688.0309



197 Ypao Road, Tamuning Guam 96913
671.649.1946
morrigoequipment.com



This message and any attachments are intended only for the use of the addressee and may contain information that is privileged and confidential. If the reader of the message is not the intended recipient or an authorized representative of the intended recipient, you are hereby notified that any dissemination of this communication is strictly prohibited. If you have received this communication in error, please notify us immediately by e-mail and delete the message and any attachments from your system.

From: Mark A. Cabrera <macabrera@portofguam.com>
Sent: Tuesday, April 23, 2024 10:55 AM
Subject: Re: Re-Bid for 180' Telescopic Boom Lift for the Port Authority of Guam

Here is the link to register for this re-bid:

[Re-bid 180' Telescopic Boom Lift - Port Authority of Guam \(portofguam.com\)](https://portofguam.com)

Thank You

Mark A. Cabrera
Procurement Buyer Supervisor



Port Authority of Guam
1026 Cabras Highway
Suite 201 Piti GU 96915
(671)477-5931 ext. 252
macabrera@portofguam.com

From: "Mark A. Cabrera" <macabrera@portofguam.com>
Sent: Tuesday, April 23, 2024 10:42:55 AM
Subject: Re-Bid for 180' Telescopic Boom Lift for the Port Authority of Guam

Hafa Adai,

This is being issued to you as it was advertised in the Guam Daily Post, and you were included in our distribution list for this project as you may have either registered or showed interest in participating.

Mark A. Cabrera
Procurement Buyer Supervisor



Port Authority of Guam
1026 Cabras Highway
Suite 201 Piti GU 96915
(671)477-5931 ext. 252
macabrera@portofguam.com



 **Acknowledgement Receipt Form - IFB-PAG-013-24 Re-bid 180 ft Telescopic Boom Lift Signed.pdf**
127 KB

Re: Re-Bid for 180' Telescopic Boom Lift for the Port Authority of Guam

From : Mark A. Cabrera <macabrera@portofguam.com>

Tue, Apr 23, 2024 10:55 AM

Subject : Re: Re-Bid for 180' Telescopic Boom Lift for the Port Authority of Guam

📎 3 attachments

Bcc : Pete Pierson <pete@federalcontractscorp.com>, Patrick Chargualaf <Patrick@morricequipment.com>, fowler <fowler@guamlawoffice.com>, etorres <etorres@midpacfareast.com>, jlimtiaco <jlimtiaco@fareastequipment.com>, dave benavente <dave.benavente@lmsfm.com>, Bob Salas <boblms@guam.net>, surfacesolutionspacific <surfacesolutionspacific@gmail.com>

Here is the link to register for this re-bid:

[Re-bid 180' Telescopic Boom Lift - Port Authority of Guam \(portofguam.com\)](https://portofguam.com)

Thank You

Mark A. Cabrera
Procurement Buyer Supervisor



Port Authority of Guam
1026 Cabras Highway
Suite 201 Piti GU 96915
(671)477-5931 ext. 252
macabrera@portofguam.com

From: "Mark A. Cabrera" <macabrera@portofguam.com>**Sent:** Tuesday, April 23, 2024 10:42:55 AM**Subject:** Re-Bid for 180' Telescopic Boom Lift for the Port Authority of Guam

Hafa Adai,

This is being issued to you as it was advertised in the Guam Daily Post, and you were included in our distribution list for this project as you may have either registered or showed interest in participating.

Mark A. Cabrera
Procurement Buyer Supervisor



Port Authority of Guam
1026 Cabras Highway
Suite 201 Piti GU 96915
(671)477-5931 ext. 252
macabrera@portofguam.com



logo.jpeg
14 KB

 **IFB-PAG-013-24.pdf**
3 MB

4a



May 10, 2024

Page 1 of 2

INTER-OFFICE MEMORANDUM

To: General Manager

Via: Deputy General Manager Admin & Finance *pm*

CC: Acting Procurement & Supply Manager *for mgs*

From: Buyer Supervisor *[Signature]*

**Subject Evaluation, Analysis, and Recommendation
Invitation for Bid (IFB) No. PAG-013-24 Re-bid for the 180' Telescopic Boom Lift**

Background

The above-referenced Invitation for Bid was publicly announced on Tuesday, April 23, 2024, in the Guam Daily Post. The bid opening was held on Wednesday, May 8, 2024, at 2:00 p.m. in the Port's Board Room.

Seven (7) prospective bidders expressed interest by registering online and downloading the bid packet from the Ports website. Two (2) bidders submitted their bid proposals before the established deadline. The bids were opened in the presence of the bidders and read aloud by the Procurement representatives. The results of the bid submittals are as follows:

Evaluation and Analysis

Pursuant to 5GCA §5211(g)n and as indicated in Section 12 of the Instruction to Bidders of the bid package, the contract is to be awarded to the lowest responsible, responsive bidder whose bid meets the requirements and criteria set forth in this Invitation for Bid. To determine the responsibility of bidders and is consistent with §3116 (2) of the Procurement Rules and Regulations, the bid package specified the required documents that bidders must submit with their bid price proposal. A summary is as follows:

1. **Federal Contractor's Corporation:** All required unsworn declarations were submitted and signed. No bid security was submitted since this was from a Federal GSA contractor. A submission of the specifications was reviewed and approved by the end-user.
2. **Morrigo Equipment:** All required unsworn declarations were submitted and signed. Bid Security was provided in the form of a bid bond covering 15% of the total bid amount. Specifications were reviewed and approved by the end-user.

Recommendation

As a result of our review of the bid documents submitted, the bidder that was determined to have met the standards of responsibility and responsiveness as outlined in the Guam Procurement Rules and Regulations, and whom provided the lowest bid was Federal Contractor's Corporation.

It is hereby recommended and concurred by Ms. Annie L.G. Sablan, Acting Procurement and Supply Manager, to award this bid to:

	Bidder	Bid Item No(s)	Total Amount
1	Federal Contractor's Corporation	1.1	\$517,205.41

Federal Funds granted by MARAD FY 2022 are available for this project. (The Requisition amount requested was \$655,000.00.) The approved funding granted by MARAD FY2022 America's Highway (AMH) Program. Grant No.: 693JF72340007 is \$655,000.00.

Pursuant to Section 3119(i)(2) of the 2 GAR, the delivery date terms are 460 days upon receipt of Purchase Order. However, the bidder has indicated a delivery of 150 days from receipt of order in which we shall clarify before award. Delivery schedule time and quantity will be coordinated between the successful bidder and the requesting department in accordance with the schedules contained in MARAD FY2022 American Marine Highway (AMH) Grant No.: 693JF72340007, and in accordance with the expiration date of this grant, currently set to expire on May 1, 2026. This project is funded by the MARAD FY2022 American Marine Highway (AMH) Grant No.: 693JF72340007.

Approved:
 Disapproved:

RORY J. RESPICIO
 General Manager

Attachments:

- *Bid Abstract*
- *End-user's Bid Specifications Evaluation*
- *Bid Submittal (Federal Contractor's Corporation)*



PORT OF GUAM
 ATURIDAT I PULU'ITON GUAHAN
Jose D. Leon Guerrero Commercial Port
 1026 Cabras Highway, Suite 201, Piti, Guam 96915
 Telephone: 671-477-5931/35 Facsimile: 671-477-2689/4445
 Website: www.portguam.com



Lourdes A. Leon Guerrero
 Governor of Guam
Joshua F. Tenorio
 Lieutenant Governor

May 9, 2024

MEMORANDUM

TO: Raymond B. Santos, Transportation Superintendent
 Shine A. San Agustin, Equipment Maintenance Superintendent
 Joaquin P. Pangelinan, Equipment Service Support Manager
FROM: Mark A. Cabrera, Buyer Supervisor
SUBJECT: Specifications Review for IFB-PAG-013-024 Re-Bid 180' Telescopic Boom Lift

Hafa Adai! Attached is the bid submittals for the Re-bid 180' Telescopic Boom Lift. Note that this was submitted via e-mail.

Please review and evaluate the submission and concur below if the bids met the minimum required specifications as set forth in the IFB. If you have any questions, please feel free to contact me at ext. 252.

Procurement appreciates your response by or before 12:00 noon Friday May 10, 2024 in order for Procurement to prepare its analysis and notices to bidders on this bid.

End User Checkmark & Initial:

Vendor: Federal Contracts Corporation



Meets specifications for bid items: _____
 Non-Compliance of Specifications for Bid Items: _____

End User Checkmark & Initial:

Vendor: Morrigo Equipment

Meets specifications for bid items: _____
 Non-Compliance of Specifications for Bid Items: _____

APPROVED BY:

Raymond B. Santos: 
 Joaquin P. Pangelinan: 
 Shine A. San Agustin: 

DATE: 05/09/2024

DATE: May 9, 2024

DATE: 5/9/24

6c

INVITATION FOR BID

ISSUING OFFICE:
PORT AUTHORITY OF GUAM
GOVERNMENT OF GUAM
1026 CABRAS HIGHWAY, SUITE 201,
PITI, GUAM 96915

RORY J. RESPICIO
GENERAL MANAGER

DATE ISSUED: 4/23/2024

BID INVITATION NO: IFB/PAG-013-24

BID FOR: **Re-bid 180' Telescopic Boom Lift**

SPECIFICATION: **SEE BELOW**

DESTINATION: PORT AUTHORITY OF GUAM

REQUIRED DELIVERY DATE: (460 days ARO) upon receipt of purchase order. Delivery schedule time and quantity will be coordinated between the successful bidder and the requesting department in accordance with the schedules contained in MARAD FY2022 American Marine Highway (AMH) Grant No. 693JF72340007, and in accordance with the expiration date of this grant, currently set to expire on May 1, 2026. This project is funded by the MARAD FY2022 American Marine Highway (AMH) Grant No.: 693JF72340007.

INSTRUCTION TO BIDDERS:

INDICATE WHETHER: INDIVIDUAL PARTNERSHIP CORPORATION

INCORPORATED IN: Florida

This bid shall be submitted in duplicate with electronic copy (pdf format) and sealed to the issuing office above no later than (Time) 2:00 PM Date: WEDNESDAY, May 8, 2024 and shall be publicly opened. Alternatively, bids may be submitted via e-mail prior to the due date and time above; please refer to the instructions below. Any bid submitted after the time and date specified above shall be rejected. See attached General Terms and Conditions, and Sealed Bid Solicitation for details.

The undersigned offers and agrees to furnish within the time specified, the articles and services at the price stated opposite the respective items listed on the schedule provided, unless otherwise specified by the bidder. In consideration to the expense of the Government in opening, tabulating, and evaluating this and other bids, and other considerations, the undersigned agrees that this bid remain firm and irrevocable within 90 calendar days from the date opening to supply any or all the items which prices are quoted.

NAME AND ADDRESS OF BIDDER:
Federal Contracts Corp
12918 N. Nebraska Ave
Tampa, FL 33612

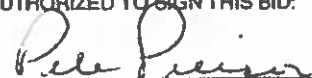
SIGNATURE AND TITLE OF PERSON
AUTHORIZED TO SIGN THIS BID:

AWARD: CONTRACT NO.: GS-03F-113DA AMOUNT: \$517,205.41 DATE: 05/07/2024

ITEM NO(S): 1.1 AWARDED: \$517,205.41

Telescopic Boom Lift, 180' Reach, Fulltime 4WD

NAME AND ADDRESS OF CONTRACTOR:
Federal Contracts Corp
12918 N. Nebraska Ave, Tampa, FL 33612

CONTRACTING OFFICER:

RORY J. RESPICIO
General Manager

SIGNATURE AND TITLE OF PERSON
AUTHORIZED TO SIGN THIS CONTRACT:

Name: Pete Pierson

Date: 4/26/24

Title: Vice President Date: 05/07/2024

SPECIAL PROVISIONS

Contract Period:

The term of this contract will continue until the expiration of the grant funds under MARAD FY2022 American Marine Highway (AMH) Grant No.: 693JF72340007 and may be extended if the period of performance for the grant funds is extended in accordance with the federal award terms and conditions. The current expiration date of the grant funds is May 1, 2026.

The initial purchase of one (1) Re-bid 180' Telescopic Boom Lift is funded by MARAD FY2022 American Marine Highway (AMH) Grant No. 693JF72340007

Contract incorporates all applicable provision of the Port Authority of Guam Federal Contract Supplement.



PORT OF GUAM
ATURIDAT / PUETTON GUAHAN
 Jose D. Leon Guerrero Commercial Port
 1026 Cabras Highway, Suite 201, Piti, Guam 96925
 Telephone: 671-477-5931/35 Facsimile: 671-477-2689/4445
 Website: www.portguam.com



Lourdes A. Leon Guerrero
 Governor of Guam
 Joshua F. Tenorio
 Lieutenant Governor

Accountability * Impartiality * Competence * Openness * Value

INVITATION FOR BID NO.: IFB-PAG-013-24

DESCRIPTION:
Re-bid 180' Telescopic Boom Lift

SPECIAL REMINDER TO PROSPECTIVE BIDDERS

Bidders are reminded to read the Sealed Bid Solicitation and Instructions, and General Terms and Conditions attached to the IFB to ascertain that all of the following requirements checked below are submitted in the bid envelope. If hard copies are submitted, One (1) original, one (1) copy, and one (1) CD or USB containing electronic file copy (in PDF format) of the complete bid proposal shall be enclosed in a sealed package or envelope at the date and time for bid opening; or bid may be submitted electronically via e-mail before the deadline, see instructions below. No award will be made until bid security is confirmed.

- BID GUARANTEE (15% of Bid Amount) May be in the form of; Reference #11 on the General Terms and Conditions**
 - a. Cashier's Check or Certified Check
 - b. Letter of Credit
 - c. Surety Bond – Valid only if accompanied by:
 - 1. Current Certificate of Authority issued by the Insurance Commissioner;
 - 2. Power of Attorney issued by the Surety to the Resident General Agent;
 - 3. Power of Attorney issued by two (2) major officers of the Surety to whoever is signing on their behalf.
- BROCHURES/DESCRIPTIVE LITERATURE;**
- AFFIDAVIT DISCLOSING OWNERSHIP and COMMISSION**
 - a. Date of signature of the person authorized to sign the bid and the notary date must be the same.
- OTHER REQUIREMENTS:**
Disclosure of Shareholder & Commission, Non-Collusion Declaration, D.O.L. Wage Determination Declaration, Restriction against Sexual Offenders Declaration, No Kickbacks or Gratuities Declaration and Ethical Standards Declaration, and Declaration re Contingent Fees, Conflict of Interest Form, SF-LLL Byrd Anti-Lobbying, and Current Business License at the time of the award.

This reminder must be signed and returned in the bid envelope together with the bid. Failure to comply with the above requirements may be cause for disqualification and rejection of the bid.

On this _____ day of _____, 2024, I, _____
 authorized representative of _____ acknowledge receipt of this special
 reminder to prospective bidders with the above referenced IFB.

 Bidder Representative's Signature

INVITATION FOR BID NO.: IFB-PAG-013-24

Re-bid 180' Telescopic Boom Lift

ACKNOWLEDGEMENT RECEIPT FORM

Please be advised that to be considered a prospective bidder you must fill out this Acknowledgement receipt form. Please submit by fax form to (671) 472-1439 or email to :macabrera@portofguam.com, and pagprocurement@portofguam.com

Acknowledgement Receipt Form must be submitted no later than three (3) days upon receipt of IFB package.

Name	<u>Pete Pierson</u>
Signature	<u></u>
Date	<u>05/07/2024</u>
Time	<u>9:00am EST</u>
Contact Number	<u>813-631-0000</u>
Fax Number	<u>813-631-0008</u>
Contact Person regarding IFB	<u>Pete Pierson</u>
Title	<u>Vice President</u>
E-Mail Address	<u>pete@federalcontractscorp.com</u>
Company/Firm	<u>Federal Contracts Corp</u>
Address	<u>12918 N. Nebraska Ave, Tampa, FL 33612</u>

Note: IFB recommends that prospective bidders register current contact information with IFB to ensure they receive any notices regarding any changes or update to the IFB. The procuring agency and IFB will not be liable for failure to provide notice to any party who did not register current contact information.

All questions and concerns in regards to this bid must be submitted to the PORT AUTHORITY OF GUAM via fax or email, addressed to the GENERAL MANAGER no later than Wednesday, May 1, 2024 by the close of business at 5:00pm. Your inquiry may be sent by fax to (671)472-1439, or emailed to rjrespicio@portofguam.com and copied to pagprocurement@portofguam.com, algsablan@portofguam.com, and macabrera@portofguam.com.

No Entitlement to Preparation Costs – the bidder expressly waives any right it may have against the government for any expenses incurred in connection with the preparation of its bid.

GOVERNMENT OF GUAM

THE PORT AUTHORITY OF GUAM
1026 Cabras Highway, Suite 201
Piti, Guam 96915

BID BOND

NO. _____

KNOW ALL MEN BY THESE PRESENTS that _____ as Principal hereinafter called the Principal, and (Bonding Company), _____ A duly admitted insurer under the laws of the Territory of Guam, as Surety, hereinafter called the Surety are Held firmly bound unto the Territory of Guam for the sum of _____ Dollars (\$ _____), for Payment of which sum will and truly to be made, the said Principal and the said Surety bind ourselves, our heirs, executors, administrators, successors and assigns, jointly and severally, firmly by these presents.

WHEREAS, the Principal has submitted a bid for (Identify project by number and brief description)

NOW, THEREFORE, if the Territory of Guam shall accept the bid of the Principal and the Principal shall enter into a Contract with the Territory of Guam in accordance with the terms of such bid, and give such bond or bonds as may be specified in bidding or Contract Documents with good and sufficient surety for the faithful performance of such Contract and for the prompt payment of labor and material furnished in the prosecution thereof, or in the event of the failure of the Principal to enter such Contract and give such bond or bonds, if the Principal shall pay to the Territory of Guam the difference not to exceed the penalty hereof between the amounts specified in said bid and such larger amount for which the Territory of Guam may in good faith contract with another party to perform work covered by said bid or an appropriate liquidated amount as specified in the Invitation for Bids then this obligation shall be null and void, otherwise to remain full force and effect.

Signed and sealed this _____ day of _____ 2024

(PRINCIPAL)

(SEAL)

(WITNESS)

(TITLE)

(MAJOR OFFICER OF SURETY)

(TITLE)

(MAJOR OFFICER OF SURETY)

(TITLE)

(RESIDENT GENERAL AGENT)

INSTRUCTION TO PROVIDERS:

NOTICE to all Insurance and Bonding Institutions:

The Bond requires the signatures of the Vendor, two (2) major Officers of the Surety and Resident General Agent, if the Surety is a foreign or alien surety.

When the form is submitted to THE PORT AUTHORITY OF GUAM, it should be accompanied with copies of

The following:

1. Current Certificate of Authority to do business on Guam issued by the Department of Revenue and Taxation.
2. Power of Attorney issued by the Surety to the Resident General Agent.
3. Power of Attorney issued by two (2) major officers of the Surety to whoever is signing on their behalf.

Bonds, submitted as Bid Guarantee, without signatures and supporting documents are invalid and Bids will be rejected.

DECLARATION RE: ETHICAL STANDARDS
[AG Form 005]

Pete Pierson [state name of declarant signing below], hereby declares that:

The declarant is Federal Contracts Corp [state one of the following: the Bidder/Offeror, a partner of the Bidder/Offeror, an officer of the Bidder/Offeror] making the foregoing identified bid or proposal. To the best of declarant's knowledge, neither declarant nor any officers, representatives, agents, subcontractors or employees of offeror have knowingly influenced any government of Guam employee to breach any of the ethical standards set forth in 5 GCA Chapter 5, Article 11. Further, declarant promises that neither he or she, nor any officer, representative, agent, subcontractor, or employee of bidder/offeror will knowingly influence any government of Guam employee to breach any ethical standards set forth in 5 GCA Chapter 5, Article 11. These statements are made pursuant to 5GCA §§ 5626, 5628 through 5633; and 2 GAR Division 4 § 11103(b).

I hereby declare under penalty of perjury under the laws of Guam that the foregoing is true and correct.

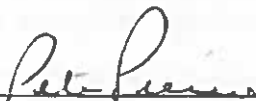

Signature of one of the following:

Bidder/ Offeror, if the bidder/offeror is an individual; Partner, if the bidder/offeror is a partnership; Officer, if the bidder/offeror is a corporation.

DECLARATION RE: NO GRATUITIES or KICKBACKS
(AG Form 004)

Pete Pierson _____ [state name of declarant signing below], hereby declare that:

1. The name of the offering firm or individual is Federal Contracts Corp [state name of bidder/offeror company] Declarant is bidder/offeror [state one of the following: the bidder/offeror, a partner of the bidder/offeror, an officer of the bidder/offeror] making the foregoing identified bid or proposal.

2. To the best of declarant's knowledge, neither declarant, nor any of the bidder's/offeror's officers, representatives, agents, subcontractors, or employees have violated, are violating the prohibition against gratuities and kickbacks set forth in 2 GAR Division 4 § 11107(e). Further, affiant promises, on behalf of bidder/offeror, not to violate the prohibition against gratuities and kickbacks as set forth in 2 GAR Division 4 § 11107(e).

3. To the best of declarant's knowledge, neither declarant, nor any of the bidders/offerors officers, representatives, agents, subcontractors, or employees have offered, given or agreed to give, any government of Guam employee or former government employee, any payment, gift, kickback, gratuity or offer of employment in connection with the bidders/offerors bid or proposal.

4. I make these statements on behalf of myself as a representative of the bidder/offeror, and on behalf of the bidder/offeror's officers, representatives, agents, subcontractors, and employees.

I hereby declare under penalty of perjury under the laws of Guam that the foregoing is true and correct.

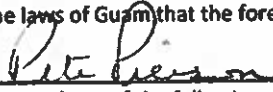

Signature of one of the following:

Offeror, if the bidder/offeror is an individual;
Partner, if the bidder/offeror is a partnership;
Officer, if the bidder/offeror is a corporation.

SPECIAL PROVISIONS

RESTRICTION AGAINST SEX OFFENDERS EMPLOYED BY SERVICES PROVIDERS TO GOVERNMENT OF GUAM FROM WORKING ON GOVERNMENT PROPERTY

If a contract for services is awarded to the bidder or offeror, then the service provider must warrant that no person in its employment who has been convicted of a sex offense under the provisions of chapter 25 of Title 9 of Guam code Annotated or of an offense defined in Article 2 of chapter 28 of Title 9 of the Guam Code annotated, or who has been convicted in any other jurisdiction of an offense with the same elements as heretofore defined, or who is listed on the Sex Offender Registry, shall provide services on behalf of the service provider while on government of Guam property, with the exception of public highways. If any employee of a service provider is providing services on government property and is convicted subsequent to an award of a contract, then the service provider warrants that it will notify the Government of the conviction within twenty-four (24) hours of the conviction, and will immediately remove such convicted person from providing services on government property. If the service provider is found to be in violation of any of the provisions of this paragraph, then the government will give notice to the service provider to take corrective action. The service provider shall take corrective action within twenty-four (24) hours of notice from the Government, and the service provider shall notify the Government when action has been taken. If the service providers fail to take corrective steps within twenty-four (24) hours of notice from the Government, then the Government in its sole discretion may suspend temporarily and contract for services until corrective action has been taken.

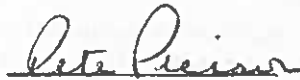
Signature of Bidder

5/7/2024
Date

Proposer, if an individual;
Partner, if a partnership;
Officer, if a corporation.

DECLARATION RE COMPLIANCE WITH U.S. D.O.L. WAGE DETERMINATION

Procurement No: IFB-PAG-013-24 Re-bid 180 FT. Telescopic Boom Lift

Name of Offeror Company: Federal Contracts Corp hereby certifies
under penalty of perjury:

(1) That I am Pete Pierson (the offeror, a partner of the offeror, an officer of the offeror) making the bid or proposal in the foregoing identified procurement;

(2) That I have read and understand the provisions of 5 GCA § 5801 and § 5802 which read:

§ 5801. Wage Determination Established.

In such cases where the government of Guam enters into contractual arrangements with a sole proprietorship, a partnership or a corporation ("contractor") for the provision of a service to the government of Guam, and in such cases where the contractor employs a person(s) whose purpose, in whole or in part, is the direct delivery of service contracted by the government of Guam, then the contractor shall pay such employee(s) in accordance with the Wage Determination for Guam and the Northern Mariana Islands issued and promulgated by the U.S. Department of Labor for such labor as is employed in the direct delivery of contract deliverables to the government of Guam.

The Wage Determination most recently issued by the U.S. Department of Labor at the time a contract is awarded to a contractor by the government of Guam shall be used to determine wages, which shall be paid to employees pursuant to this Article. Should any contract contain a renewal clause, then at the time of renewal adjustments, there shall be made stipulations contained in that contract for applying the Wage Determination, as required by this Article, so that the Wage Determination promulgated by the U.S. Department of Labor on a date most recent to the renewal date shall apply.

§ 5802. Benefits.

In addition to the Wage Determination detailed in this Article, any contract to which this Article applies shall also contain provisions mandating health and similar benefits for employees covered by this Article, such benefits having a minimum value as detailed in the Wage Determination issued and promulgated by the U.S. Department of Labor, and shall contain provisions guaranteeing a minimum of ten (10) paid holidays per annum per employee.

(3) That the offeror is in full compliance with 5 GCA § 5801 and § 5802, as may be applicable to the procurement referenced herein;

(4) That I have attached the most recent wage determination applicable to Guam issued by the U.S. Department of Labor. [INSTRUCTIONS – Please attach]

Pete Pierson 05/07/2024
Signature Date

*REGISTER OF WAGE DETERMINATIONS |
UNDER THE SERVICE CONTRACT ACT |
By direction of the Secretary of Labor |
Daniel W. Simms, Division of |
Director Wage Determinations |

U.S. DEPARTMENT OF LABOR
EMPLOYMENT STANDARDS ADMINISTRATION
WAGE AND HOUR DIVISION
WASHINGTON D.C. 20210
Wage Determination No.: 2015-5693
Revision No.: 19 | Date of Last Revision: 07/17/2023

Note: Contracts subject to the Service Contract Act are generally required to pay at least the applicable minimum wage rate required under Executive Order 14026. If the contract is entered into on or after January 30 2022 or the contract is renewed or extended (e.g., an option is exercised) on or after January 30 2022: The contractor must pay all covered workers at least \$16.20 per hour (or the applicable wage rate listed on this wage determination if it is higher) for all hours spent performing on the contract in 2023.

The applicable Executive Order minimum wage rate will be adjusted annually. Additional information on contractor requirements and worker protections under the Executive Orders is available at <https://www.dol.gov/agencies/whd/government-contracts>.

States: Guam Northern Marianas Wake Island
Area: Guam Statewide
Northern Marianas Statewide
Wake Island Statewide

Fringe Benefits Required Follow the Occupational Listing

OCCUPATION CODE - TITLE	FOOTNOTE RATE	OCCUPATION CODE - TITLE	FOOTNOTE RATE
-------------------------	---------------	-------------------------	---------------

01000 - Administrative Support And Clerical Occupations

01011 - Accounting Clerk I	34.27***
01012 - Accounting Clerk II	36.02***
01013 - Accounting Clerk III	17.93
01020 - Administrative Assistant	21.43
01035 - Court Reporter	17.40
01041 - Customer Service Representative I	12.75***
01042 - Customer Service Representative II	14.23***
01043 - Customer Service Representative III	15.62***
01051 - Data Entry Operator I	12.16***
01052 - Data Entry Operator II	13.27***
01060 - Dispatcher, Motor Vehicle	17.39
01070 - Document Preparation Clerk	13.85***
01090 - Duplicating Machine Operator	13.85***
01111 - General Clerk I	11.33***
01112 - General Clerk II	12.96***
01113 - General Clerk III	13.88***
01120 - Housing Referral Assistant	19.39
01141 - Messenger Courier	11.37***
01191 - Order Clerk I	12.57***
01192 - Order Clerk II	13.73***
01261 - Personnel Assistant (Employment) I	15.95***
01262 - Personnel Assistant (Employment) II	17.85
01263 - Personnel Assistant (Employment) III	19.89
01270 - Production Control Clerk	22.97
01290 - Rental Clerk	11.10***
01300 - Scheduler, Maintenance	15.55***
01311 - Secretary I	15.55***
01312 - Secretary II	17.40
01313 - Secretary III	19.39
01320 - Service Order Dispatcher	15.40***
01410 - Supply Technician	21.43
01420 - Survey Worker	16.96
01460 - Switchboard Operator/Receptionist	10.78***
01531 - Travel Clerk I	13.01***
01532 - Travel Clerk II	14.12***
01533 - Travel Clerk III	15.09***
01611 - Word Processor I	14.53***
01613 - Word Processor III	18.26
05000 - Automotive Service Occupations	
05005 - Automobile Body Repairer, Fiberglass	17.20
05010 - Automotive Electrician	16.16***
05040 - Automotive Glass Installer	15.11***
05070 - Automotive Worker	15.11***
05110 - Mobile Equipment Servicer	12.96***
05130 - Motor Equipment Metal Mechanic	17.20
05160 - Motor Equipment Metal Worker	15.11***
05190 - Motor Vehicle Mechanic	17.20
05220 - Motor Vehicle Mechanic Helper	11.87***
05250 - Motor Vehicle Upholstery Worker	14.06***
05280 - Motor Vehicle Wrecker	15.11***
05310 - Painter, Automotive	16.16***
05340 - Radiator Repair Specialist	15.11***
05370 - Tire Repairer	12.67***
05400 - Transmission Repair Specialist	17.20
07000 - Food Preparation And Service Occupations	
07010 - Baker	11.10***
07041 - Cook I	14.44***
07042 - Cook II	16.84
07070 - Dishwasher	9.69***
07130 - Food Service Worker	10.12***
07210 - Meat Cutter	13.34***
07260 - Waiter/Waitress	9.73***

09000 - Furniture Maintenance And Repair Occupations

09010 - Electrostatic Spray Painter	18.75
09040 - Furniture Handler	11.37***
09080 - Furniture Refinisher	18.75
09090 - Furniture Refinisher Helper	13.77***
09110 - Furniture Repairer, MI	16.32
09130 - Upholsterer	18.75
11000 - General Services And Support Occupations	
11030 - Cleaner, Vehicles	9.69***
11060 - Elevator Operator	9.69***
11090 - Gardener	14.28***
11122 - Housekeeping Aide	10.13***
11150 - Janitor	10.13***
11210 - Laborer, Grounds Maintenance	10.79***
11240 - Maid or Houseman	9.67***
11260 - Pruner	9.66***
11270 - Tractor Operator	13.07***
11330 - Trail Maintenance Worker	10.79***
01612 - Word Processor II	16.31
11360 - Window Cleaner	11.32***
12000 - Health Occupations	
12010 - Ambulance Driver	18.95
12011 - Breath Alcohol Technician	18.96
12012 - Certified Occupational Therapist Assistant	26.02
12015 - Certified Physical Therapist Assistant	26.02
12020 - Dental Assistant	18.79
12025 - Dental Hygienist	39.73
12030 - EKG Technician	28.73
12035 - Electroneurodiagnostic Technologist	28.73
12040 - Emergency Medical Technician	18.96
12071 - Licensed Practical Nurse I	16.95
12072 - Licensed Practical Nurse II	18.96
12073 - Licensed Practical Nurse III	21.14
12100 - Medical Assistant	13.42***
12130 - Medical Laboratory Technician	18.82
12160 - Medical Record Clerk	14.97***
12190 - Medical Record Technician	37.77
12195 - Medical Transcriptionist	16.95
12210 - Nuclear Medicine Technologist	41.68
12221 - Nursing Assistant I	12.43***
12222 - Nursing Assistant II	13.97***
12223 - Nursing Assistant III	15.24***
12224 - Nursing Assistant IV	17.12
12235 - Optical Dispenser	18.96
12236 - Optical Technician	16.95
12250 - Pharmacy Technician	15.49***
12280 - Phlebotomist	16.95
12305 - Radiologic Technologist	28.73
12311 - Registered Nurse I	23.50
12312 - Registered Nurse II	28.73
12313 - Registered Nurse II, Specialist	28.73
12314 - Registered Nurse III	34.76
12315 - Registered Nurse III, Anesthetist	34.76
12316 - Registered Nurse IV	41.68
12317 - Scheduler (Drug and Alcohol Testing)	23.50
12320 - Substance Abuse Treatment Counselor	23.50
13000 - Information And Arts Occupations	
13011 - Exhibits Specialist I	21.42
13012 - Exhibits Specialist II	26.53
13013 - Exhibits Specialist III	32.45
13041 - Illustrator I	21.42
13042 - Illustrator II	26.53
13043 - Illustrator III	32.45

OCCUPATION CODE - TITLE	FOOTNOTE RATE	FOOTNOTE
13047 - Librarian	29.38	
13050 - Library Aide/Clerk	17.05	
13054 - Library Information Technology Systems Administrator	26.53	
13058 - Library Technician	18.11	
13061 - Media Specialist I	19.15	
13062 - Media Specialist II	21.42	
13063 - Media Specialist III	23.87	
13071 - Photographer I	19.15	
13072 - Photographer II	21.42	
13073 - Photographer III	26.53	
13074 - Photographer IV	32.45	
13075 - Photographer V	39.27	
13090 - Technical Order Library Clerk	21.42	
13110 - Video Teleconference Technician	19.15	
14000 - Information Technology Occupations		
14041 - Computer Operator I	15.71***	
14042 - Computer Operator II	17.22	
14043 - Computer Operator III	19.19	
14044 - Computer Operator IV	21.33	
14045 - Computer Operator V	23.62	
14071 - Computer Programmer I (see 1)	15.73***	
14072 - Computer Programmer II (see 1)	19.50	
14073 - Computer Programmer III (see 1)	23.84	
14074 - Computer Programmer IV (see 1)		
14101 - Computer Systems Analyst I (see 1)	24.23	
14102 - Computer Systems Analyst II (see 1)		
14103 - Computer Systems Analyst III (see 1)		
14150 - Peripheral Equipment Operator	15.71***	
14160 - Personal Computer Support Technician	21.33	
14170 - System Support Specialist	21.24	
15000 - Instructional Occupations		
15010 - Aircrew Training Devices Instructor (Non-Rated)	24.23	
15020 - Aircrew Training Devices Instructor (Rated)	29.32	
15030 - Air Crew Training Devices Instructor (Pilot)	34.91	
15050 - Computer Based Training Specialist / Instructor	24.23	
15060 - Educational Technologist	29.40	
15070 - Flight Instructor (Pilot)	34.91	
15080 - Graphic Artist	20.47	
15085 - Maintenance Test Pilot, Fixed, Jet/Prop	34.91	
15086 - Maintenance Test Pilot, Rotary Wing	34.91	
15088 - Non-Maintenance Test/Co-Pilot	34.91	
15090 - Technical Instructor	17.67	
15095 - Technical Instructor/Course Developer	23.78	
15110 - Test Proctor	15.70***	
15120 - Tutor	15.70***	
16000 - Laundry, Dry-Cleaning, Pressing And Related Occupations		
16010 - Assembler	10.83***	
16030 - Counter Attendant	10.83***	
16040 - Dry Cleaner	12.36***	
16070 - Finisher, Flatwork, Machine	10.83***	
16090 - Presser, Hand	10.83***	
16110 - Presser, Machine, Drycleaning	10.83***	
16130 - Presser, Machine, Shirts	10.83***	
16160 - Presser, Machine, Wearing Apparel, Laundry	10.83***	
16190 - Sewing Machine Operator	12.88***	
16220 - Tailor	13.40***	
16250 - Washer, Machine	11.34***	
19000 - Machine Tool Operation And Repair Occupations		
19010 - Machine-Tool Operator (Tool Room)	19.46	
19040 - Tool And Die Maker	24.46	
21000 - Materials Handling And Packing Occupations		
21020 - Forklift Operator	15.36***	
21030 - Material Coordinator	22.97	
21040 - Material Expediter	22.97	
21050 - Material Handling Laborer	12.57***	
21071 - Order Filler	10.62***	
21080 - Production Line Worker (Food Processing)	15.36***	
21110 - Shipping Packer	17.12	
21130 - Shipping/Receiving Clerk	17.12	
21140 - Store Worker I	15.83***	
21150 - Stock Clerk	22.26	
21210 - Tools And Parts Attendant	15.36***	
21410 - Warehouse Specialist	15.36***	
23000 - Mechanics And Maintenance And Repair Occupations		
23010 - Aerospace Structural Welder	25.04	
23019 - Aircraft Logs and Records Technician	19.47	
23021 - Aircraft Mechanic I	23.84	
23022 - Aircraft Mechanic II	25.04	
23023 - Aircraft Mechanic III	26.30	
23040 - Aircraft Mechanic Helper	16.58	
23050 - Aircraft, Painter	22.39	
23060 - Aircraft Servicer	19.47	
23070 - Aircraft Survival Flight Equipment Technician	22.39	
23080 - Aircraft Worker	21.03	
23091 - Aircrew Life Support Equipment (ALSE) Mechanic 21.03		
23092 - Aircrew Life Support Equipment (ALSE) Mechanic 23.84		

OCCUPATION CODE - TITLE FOOTNOTE RATE

OCCUPATION CODE - TITLE	FOOTNOTE RATE	RAT
23110 - Appliance Mechanic	19.46	
23120 - Bicycle Repairer	15.61***	
23125 - Cable Splicer	22.47	
23130 - Carpenter, Maintenance	17.58	
23140 - Carpet Layer	18.20	
23160 - Electrician, Maintenance	19.37	
23181 - Electronics Technician Maintenance I	18.20	
23182 - Electronics Technician Maintenance II	19.46	
23183 - Electronics Technician Maintenance III	20.72	
23260 - Fabric Worker	16.94	
23290 - Fire Alarm System Mechanic	16.77	
23310 - Fire Extinguisher Repairer	15.61***	
23311 - Fuel Distribution System Mechanic	20.72	
23312 - Fuel Distribution System Operator	15.61***	
23370 - General Maintenance Worker	13.24***	
23380 - Ground Support Equipment Mechanic	23.84	
23381 - Ground Support Equipment Servicer	19.47	
23382 - Ground Support Equipment Worker	21.03	
23391 - Gunsmith I	15.61***	
23392 - Gunsmith II	18.20	
23393 - Gunsmith III	20.72	
23410 - Heating, Ventilation And Air-Conditioning Mechanic	19.27	
23411 - Heating, Ventilation And Air Conditioning Mechanic (Research Facility)	20.50	
23430 - Heavy Equipment Mechanic	19.50	
23440 - Heavy Equipment Operator	18.10	
23460 - Instrument Mechanic	20.72	
23465 - Laboratory/Shelter Mechanic	19.46	
23470 - Laborer	15.73***	
23510 - Locksmith	19.46	
23530 - Machinery Maintenance Mechanic	23.13	
23550 - Machinist, Maintenance	20.72	
23580 - Maintenance Trades Helper	11.77***	
23591 - Metrology Technician I	20.72	
23592 - Metrology Technician II	22.03	
23593 - Metrology Technician III	23.33	
23640 - Millwright	20.72	
23710 - Office Appliance Repairer	19.46	
23760 - Painter, Maintenance	17.04	
23790 - Pipefitter, Maintenance	19.96	
23830 - Plumber, Maintenance	18.75	
23820 - Pneumatic Systems Mechanic	20.72	
23850 - Rigger	20.72	
23870 - Scale Mechanic	18.20	
23890 - Sheet-Metal Worker, Maintenance	19.55	
23910 - Small Engine Mechanic	18.20	
23931 - Telecommunications Mechanic I	19.96	
23932 - Telecommunications Mechanic II	21.24	
23950 - Telephone Lineman	20.62	
23960 - Welder, Combination, Maintenance	19.96	
23965 - Well Driller	21.13	
23970 - Woodcraft Worker	20.71	
23980 - Woodworker	15.61***	
24000 - Personal Needs Occupations		
24550 - Case Manager	15.01***	
24570 - Child Care Attendant	10.09***	
24580 - Child Care Center Clerk	13.25***	
24610 - Chore Aide	14.06***	
24620 - Family Readiness And Support Services Coordinator	15.01***	
24630 - Homemaker	16.12***	
25000 - Plant And System Operations Occupations		
25010 - Boiler Tender	22.79	
25040 - Sewage Plant Operator	22.89	
25070 - Stationary Engineer	22.79	
25190 - Ventilation Equipment Tender	15.72***	
25210 - Water Treatment Plant Operator	22.89	
27000 - Protective Service Occupations		
27004 - Alarm Monitor	10.90***	
27007 - Baggage Inspector	9.63***	
27008 - Corrections Officer	14.59***	
27010 - Court Security Officer	14.59***	
27030 - Detection Dog Handler	10.90***	
27040 - Detention Officer	14.59***	
27070 - Firefighter	14.59***	
27101 - Guard I	9.63***	
27102 - Guard II	10.90***	
27131 - Police Officer I	14.59***	
27132 - Police Officer II	16.21	
28000 - Recreation Occupations		
28041 - Carnival Equipment Operator	13.24***	
28042 - Carnival Equipment Repairer	14.46***	
28043 - Carnival Worker	9.78***	
28210 - Gate Attendant/Gate Tender	13.18***	

OCCUPATION CODE - TITLE FOOTNOTE RATE

28310 - Lifeguard	11.01***		99000 - Miscellaneous Occupations	
28350 - Park Attendant (Aide)	14.74***		99020 - Cabin Safety Specialist	16.14***
28510 - Recreation Aide/Health Facility Attendant	11.84***		99030 - Cashier	10.01***
28515 - Recreation Specialist	18.26		99050 - Desk Clerk	9.71***
29000 - Stevedoring/Longshoremen Occupational Services			99095 - Embalmer	27.37
29010 - Blocker And Bracer	26.02		99130 - Flight Follower	27.37
29020 - Hatch Tender	26.02		99251 - Laboratory Animal Caretaker I	
29030 - Line Handler	26.02		24.31	
29041 - Stevedore I	24.21		99252 - Laboratory Animal Caretaker II	
29042 - Stevedore II	27.82		26.56	
30000 - Technical Occupations			99260 - Marketing Analyst	21.54
30010 - Air Traffic Control Specialist, Center (HFO) (see 2)	43.06		99310 - Mortician	27.37
30011 - Air Traffic Control Specialist, Station (HFO) (see 2)	29.69		99410 - Pest Controller	16.07***
30012 - Air Traffic Control Specialist, Terminal (HFO) (see 2)	32.70		99510 - Photofinishing Worker	
30021 - Archeological Technician I	18.17		14.38***	
30022 - Archeological Technician II	20.33		99710 - Recycling Laborer	
30023 - Archeological Technician III	25.19		17.32	
30030 - Cartographic Technician	25.19		99711 - Recycling Specialist	
30040 - Civil Engineering Technician	25.19		23.38	
30051 - Cryogenic Technician I	27.89		99730 - Refuse Collector	16.40
30052 - Cryogenic Technician II	30.80		99810 - Sales Clerk	10.63***
30061 - Drafter/CAD Operator I	18.17		99820 - School Crossing Guard	17.96
30062 - Drafter/CAD Operator II	20.33		99830 - Survey Party Chief	23.99
30063 - Drafter/CAD Operator III	22.66		99831 - Surveying Aide	13.65***
30064 - Drafter/CAD Operator IV	27.89		99832 - Surveying Technician	17.73
30081 - Engineering Technician I	16.19***		99840 - Weaving Machine Attendant	24.31
30082 - Engineering Technician II	18.17		99841 - Weaving Machine Repairer	30.96
30083 - Engineering Technician III	20.33			
30084 - Engineering Technician IV	25.19			
30085 - Engineering Technician V	30.80			
30086 - Engineering Technician VI	37.27			
30090 - Environmental Technician	25.19			
30095 - Evidence Control Specialist	25.19			
30210 - Laboratory Technician	22.66			
30221 - Latent Fingerprint Technician I	27.89			
30222 - Latent Fingerprint Technician II	30.80			
30240 - Mathematical Technician	25.19			
30361 - Paralegal/Legal Assistant I	19.54			
30362 - Paralegal/Legal Assistant II	24.21			
30363 - Paralegal/Legal Assistant III	29.61			
30364 - Paralegal/Legal Assistant IV	35.83			
30375 - Petroleum Supply Specialist	30.80			
30390 - Photo-Optics Technician	24.92			
30395 - Radiation Control Technician	30.80			
30461 - Technical Writer I	25.19			
30462 - Technical Writer II	30.80			
30463 - Technical Writer III	37.27			
30491 - Unexploded Ordnance (UXO) Technician I	27.37			
30492 - Unexploded Ordnance (UXO) Technician II	33.11			
30493 - Unexploded Ordnance (UXO) Technician III	39.69			
30494 - Unexploded (UXO) Safety Escort	27.37			
30495 - Unexploded (UXO) Sweep Personnel	27.37			
30501 - Weather Forecaster I	27.89			
30502 - Weather Forecaster II	33.93			
30620 - Weather Observer, Combined Upper Air Or Surface Programs (see 2)	22.66			
30621 - Weather Observer, Senior (see 2)	25.19			
31000 - Transportation/Mobile Equipment Operation Occupations				
31010 - Airplane Pilot	33.11			
31020 - Bus Aide	8.97***			
31030 - Bus Driver	11.73***			
31043 - Driver Courier	10.26***			
31260 - Parking and Lot Attendant	9.91***			
31290 - Shuttle Bus Driver	11.65***			
31310 - Taxi Driver	11.41***			
31361 - Truckdriver, Light	11.21***			
31362 - Truckdriver, Medium	12.16***			
31363 - Truckdriver, Heavy	16.11***			
31364 - Truckdriver, Tractor-Trailer	16.11***			

***Workers in this classification may be entitled to a higher minimum wage under Executive Order 14026 (\$16.20 per hour). Please see the Note at the top of the wage determination for more information. Please also note that the minimum wage requirements of Executive Order 14026 are not currently being enforced as to contracts or contract-like instruments entered into with the federal government in connection with seasonal recreational services or seasonal recreational equipment rental for the general public on federal lands.

ALL OCCUPATIONS LISTED ABOVE RECEIVE THE FOLLOWING BENEFITS:

HEALTH & WELFARE: \$4.98 per hour, up to 40 hours per week, or \$199.20 per week or \$863.20 per month

HEALTH & WELFARE EO 13706: \$4.57 per hour, up to 40 hours per week, or \$182.80 per week, or \$792.13 per month*

*This rate is to be used only when compensating employees for performance on an SCA-covered contract also covered by EO 13706, Establishing Paid Sick Leave for Federal Contractors. A contractor may not receive credit toward its SCA obligations for any paid sick leave provided pursuant to EO 13706.

VACATION: 2 weeks paid vacation after 1 year of service with a contractor or successor; and 4 weeks after 3 years. Length of service includes the whole span of continuous service with the present contractor or successor, wherever employed, and with the predecessor contractors in the performance of similar work at the same Federal facility. (Reg. 29 CFR 4.173) **HOLIDAYS:** A minimum of eleven paid holidays per year: New Year's Day, Martin Luther King Jr.'s Birthday, Washington's Birthday, Memorial Day, Juneteenth National Independence Day, Independence Day, Labor Day, Columbus Day, Veterans' Day, Thanksgiving Day, and Christmas Day. (A contractor may substitute for any of the named holidays another day off with pay in accordance with a plan communicated to the employees involved.) (See 29 CFR 4.174)

THE OCCUPATIONS WHICH HAVE NUMBERED FOOTNOTES IN PARENTHESES RECEIVE THE FOLLOWING:

1) **COMPUTER EMPLOYEES:** This wage determination does not apply to any individual employed in a bona fide executive, administrative, or professional capacity, as defined in 29 C.F.R. Part 541. (See 41 C.F.R. 6701(3)). Because most Computer Systems Analysts and Computer Programmers who are paid at least \$27.63 per hour (or at least \$684 per week if paid on a salary or fee basis) likely qualify as exempt computer professionals under 29 U.S.C. 213(a)(1) and 29 U.S.C. 213(a)(17), this wage determination may not include wage rates for all occupations within those job families. In such instances, a conformance will be necessary if there are nonexempt employees in these job families working on the contract.

Job titles vary widely and change quickly in the computer industry, and are not determinative of whether an employee is an exempt computer professional. To be exempt, computer employees who satisfy the compensation requirements must also have a primary duty that consists of:

- (1) The application of systems analysis techniques and procedures, including consulting with users, to determine hardware, software or system functional specifications;
- (2) The design, development, documentation, analysis, creation, testing or modification of computer systems or programs, including prototypes, based on and related to user or system design specifications;
- (3) The design, documentation, testing, creation or modification of computer programs related to machine operating systems; or
- (4) A combination of the aforementioned duties, the performance of which requires the same level of skills. (29 C.F.R. 541.400).

Any computer employee who meets the applicable compensation requirements and the above duties test qualifies as an exempt computer professional under both section 13(a)(1) and section 13(a)(17) of the Fair Labor Standards Act. (Field Assistance Bulletin No. 2006-3 (Dec. 14, 2006)). Accordingly, this wage determination will not apply to any exempt computer employee regardless of which of these two exemptions is utilized.

2) **AIR TRAFFIC CONTROLLERS AND WEATHER OBSERVERS - NIGHT PAY & SUNDAY PAY:** If you work at night as part of a regular tour of duty, you will earn a night differential and receive an additional 10% of basic pay for any hours worked between 6pm and 6am. If you are a full-time employed (40 hours a week) and Sunday is part of your regularly scheduled workweek, you are paid at your rate of basic pay plus a Sunday premium of 25% of your basic rate for each hour of Sunday work which is not overtime (i.e.: occasional work on Sunday outside the normal tour of duty is considered overtime work).

**** HAZARDOUS PAY DIFFERENTIAL ****

A 6 percent differential is applicable to employees employed in a position that represents a high degree of hazard when working with or in close proximity to ordnance, explosives, and incendiary materials. This includes work such as screening, blending, drying, mixing, and pressing of sensitive ordnance, explosives, and pyrotechnic compositions such as lead azide, black powder and photoflash powder. All dry-house activities involving propellants or explosives. Demilitarization, modification, renovation, demolition, and maintenance operations on sensitive ordnance, explosives and incendiary materials. All operations involving re-grading and cleaning of artillery ranges.

A 4 percent differential is applicable to employees employed in a position that represents a low degree of hazard when working with, or in close proximity to ordnance, (or employees possibly adjacent to) explosives and incendiary materials which involves potential injury such as laceration of hands, face, or arms of the employee engaged in the operation, irritation of the skin, minor burns and the like; minimal damage to immediate or adjacent work area or equipment being used. All operations involving, unloading, storage, and hauling of ordnance, explosive, and incendiary ordnance material other than small arms ammunition. These differentials are only applicable to work that has been specifically designated by the agency for ordnance, explosive, and incendiary material differential pay.

**** UNIFORM ALLOWANCE ****

If employees are required to wear uniforms in the performance of this contract (either by the terms of the Government contract, by the employer, by the state or local law, etc.), the cost of furnishing such uniforms and maintaining (by laundering or dry cleaning) such uniforms is an expense that may not be borne by an employee where such cost reduces the hourly rate below that required by the wage determination. The Department of Labor will accept payment in accordance with the following standards as compliance:

The contractor or subcontractor is required to furnish all employees with an adequate number of uniforms without cost or to reimburse employees for the actual cost of the uniforms. In addition, where uniform cleaning and maintenance is made the responsibility of the employee, all contractors and subcontractors subject to this wage determination shall (in the absence of a bona fide collective bargaining agreement providing for a different amount, or the furnishing of contrary affirmative proof as to the actual cost), reimburse all employees for such cleaning and maintenance at a rate of \$3.35 per week (or \$67 cents per day). However, in those instances where the uniforms furnished are made of "wash and wear" materials, may be routinely washed and dried with other personal garments, and do not require any special treatment such as dry cleaning, daily washing, or commercial laundering in order to meet the cleanliness or appearance standards set by the terms of the Government contract, by the contractor, by law, or by the nature of the work, there is no requirement that employees be reimbursed for uniform maintenance costs.

**** SERVICE CONTRACT ACT DIRECTORY OF OCCUPATIONS ****

The duties of employees under job titles listed are those described in the "Service Contract Act Directory of Occupations", Fifth Edition (Revision 1), dated September 2015, unless otherwise indicated.

**** REQUEST FOR AUTHORIZATION OF ADDITIONAL CLASSIFICATION AND WAGE RATE, Standard Form 1444 (SF-1444) ****

Conformance Process: The contracting officer shall require that any class of service employee which is not listed herein and which is to be employed under the contract (i.e., the work to be performed is not performed by any classification listed in the wage determination), be classified by the contractor so as to provide a reasonable relationship (i.e., appropriate level of skill comparison) between such unlisted classifications and the classifications listed in the wage determination (See 29 CFR 4.6(b)(2)(i)). Such conforming procedures shall be initiated by the contractor prior to the performance of contract work by such unlisted class(es) of employees (See 29 CFR 4.6(b)(2)(ii)). The Wage and Hour Division shall make a final determination of conformed classification, wage rate, and/or fringe benefits which shall be paid to all employees performing in the classification from the first day of work on which contract work is performed by them in the classification. Failure to pay such unlisted employees the compensation agreed upon by the interested parties and/or fully determined by the Wage and Hour Division retroactive to the date such class of employees commenced contract work shall be a violation of the Act and this contract. (See 29 CFR 4.6(b)(2)(v)). When multiple wage determinations are included in a contract, a separate SF-1444 should be prepared for each wage determination to which a class(es) is to be conformed.

The process for preparing a conformance request is as follows:

- 1) When preparing the bid, the contractor identifies the need for a conformed occupation(s) and computes a proposed rate(s).
- 2) After contract award, the contractor prepares a written report listing in order the proposed classification title(s), a federal grade equivalency (FGE) for each proposed classification(s), job description(s), and rationale for proposed wage rate(s), including information regarding the agreement or disagreement of the authorized representative of the employees involved, or where there is no authorized representative, the employees themselves. This report should be submitted to the contracting officer no later than 30 days after such unlisted class(es) of employees performs any contract work.
- 3) The contracting officer reviews the proposed action and promptly submits a report of the action, together with the agency's recommendations and pertinent information including the position of the contractor and the employees, to the U.S. Department of Labor, Wage and Hour Division, for review (See 29 CFR 4.6(b)(2)(ii)).
- 4) Within 30 days of receipt, the Wage and Hour Division approves, modifies, or disapproves the action via transmittal to the agency contracting officer, or notifies the contracting officer that additional time will be required to process the request.
- 5) The contracting officer transmits the Wage and Hour Division's decision to the contractor.

6) Each affected employee shall be furnished by the contractor with a written copy of such determination or it shall be posted as a part of the wage determination (See 29 CFR 4.6(b)(2)(iii)).

Information required by the Regulations must be submitted on SF-1444 or bond paper.

When preparing a conformance request, the "Service Contract Act Directory of Occupations" should be used to compare job definitions to ensure that duties requested are not performed by a classification already listed in the wage determination. Remember, it is not the job title, but the required tasks that determine whether a class is included in an established wage determination. Conformances may not be used to artificially split, combine, or subdivide classifications listed in the wage determination (See 29 CFR 4.152(c)(1))."

DECLARATION RE: NON-COLLUSION
(AG FORM 003)

Pete Pierson

[state name of declarant signing below], declares that:

1. The name of the bidding/offering company or individual is [state name of company]
Federal Contracts Corp

2. The Bid/Proposal for the solicitation identified above is genuine and not collusive or a sham. The bidder/offeror has not colluded, conspired, connived or agreed, directly or indirectly, with any other bidder/offeror or person, to put in a sham bid/proposal or to refrain from making an offer. The bidder/offeror has not in any manner, directly or indirectly, sought by an agreement or collusion, or communication or conference, with any person to fix the proposal price of bidder/offeror or of any other bidder/offeror, or to fix any overhead, profit or cost element of said proposal price, or of that of any other bidder/offeror, or to secure any advantage against the government of Guam or any other bidder/offeror, or to secure any advantage against the government of Guam or any person interested in the proposed contract. All statements in this affidavit and in the proposal are true to the best of the knowledge of the undersigned. This statement is made pursuant to 2 GAR Division 4 § 3126(b).

3. I make this statement on behalf of myself as a representative of the bidder/offeror, and on behalf of the bidder/offeror's officers, representatives, agents, subcontractors, and employees.

I hereby declare under penalty of perjury under the laws of Guam that the foregoing is true and correct.

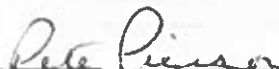

Signature of one of the following:

Offeror, if the bidder/offeror is an individual;
Partner, if the bidder/offeror is a partnership;
Officer, if the bidder/offeror is a corporation.

**DECLARATION DISCLOSING OWNERSHIP, INFLUENCE, COMMISSIONS
AND CONFLICTS OF INTEREST**

(Required by 5 GCA § 5233 as amended by P.L. 36-13 (4/9/2021))

Preface. As a condition of submitting a Bid/Offer/Proposal or responding to any method of source selection under Guam's Procurement Law for the purpose of entering into a contract with the government of Guam, this Affidavit requires all Bidders/Offerors/Prospective Contractors to make disclosures of ownership, influence, commissions, gratuities, kickbacks, and conflicts of interest occurring during the 365 calendar days preceding the publication of this solicitation and until award of a contract. This includes the duty to disclose any changes to the facts disclosed herein throughout the solicitation process; and if the entity submitting this Affidavit is awarded a contract, the duty to disclose any changes to the facts disclosed herein continues throughout the life of the contract, including any extensions or renewals.

A. I, the undersigned, hereby declare that I am an authorized representative of the Bidder/Offeror/Prospective Contractor and that (please check and fill out all that apply):

The Bidder/Offeror/Prospective Contractor is an individual with a business license, and all decisions are by, and all profit is for, that same individual, with principal place of business street address being:

The Bidder/Offeror/Prospective Contractor is a business or artificial person (as defined in 1 GCA § 715 or 5 GCA §§ 5030(n) or 5233(b)), and is a sole proprietorship owned entirely (100%) by _____, with principal place of business street address being:

The Bidder/Offeror/Prospective Contractor is a business or artificial person (as defined in 1 GCA § 715 or 5 GCA §§ 5030(n) or 5233(b)), and is owned by the following multiple individuals. Note: owners of more than 10% are statutorily required to be listed below, but other owners of smaller percentage are encouraged to be listed as well.

Name of Owner	Principal Place of Business Street Address	% of Interest
Clark Ricke	12918 N. Nebraska Ave	51%
Steve Ricke	" "	16.3%
Chris Rey	" "	16.3%
Pete Pierson	" "	16.3%

One or more of the more-than-10% owners listed above is a business or artificial person. Any more-than-25% owners of such a business or artificial person are listed below per 5 GCA § 5233. Note: any less-than-25% owners of such a business or artificial person is encouraged to also be listed below.

Name of >10% Owner Business or Artificial Person:

Names of owners of the >10% Owner Business or Artificial Person ("Second Tier Owner")	Owner's Principal Place of Business Street Address	% of Interest

Name of other >10% Owner Business or Artificial Person:

--

Names of owners of the >10% Owner Business or Artificial Person ("Second Tier Owner")	Owner's Principal Place of Business Street Address	% of Interest

B. If any Second Tier Owner identified above is an artificial person, the natural or artificial owners of such Second Tier Owner who have held more than 49% of the shares or interest in the Bidder/Offeror/Prospective Contractor (Third Tier Owners) are as follows (if none, please so state):

Second Tier Owner Name _____

Name of Third Tier Owner	Principal Place of Business Street Address	% of Interest

C. If the name of no natural person has been identified as an owner, or a Second or Third Tier Owner of the Bidder/Offeror/Prospective Contractor, please identify the name, position, address, and contact information of the natural person having the authority and responsibility for the Bid/Offer/Proposal/Prospective Contract, and the name of any natural person who has the authority and power to remove and replace the designated responsible person:

Name of Natural Person	Position	Street Address of Principal Place of Business	Phone Number, Email Address, and other Contact Information

D. Further, I say that the persons who have received or are entitled to receive a commission, gratuity, contingent fee or other compensation to solicit, secure, or assist in obtaining business related to the Bid/Offer/Proposal/Prospective Contract for which this Affidavit is submitted are as follows (if none, please so state):

Name	Principal Place of Business Street Address	Amount of Compensation

E. Further, I say that the persons who have directly or indirectly participated in this solicitation and who are also employees of the government of Guam or the government of the United States, if federal funds are to be used

in the payment of the contract related to the Bid/Offer/Proposal/Prospective Contract for which this Affidavit is submitted, are as follows (if none, please so state):

Name	Principal Place of Business Street Address
_____	_____
_____	_____

F. Regardless of any ownership interest, the following individuals have the power to control the performance of the contract or to control the Bidder/Offeror/Prospective Contractor, directly or indirectly:

Name	Principal Place of Business Street Address
_____	_____
_____	_____

G. Until award of the contract, and throughout the term of any contract awarded to the Bidder/Offeror/Prospective Contractor represented herein, I agree to promptly make any disclosures not made previously and update changes in ownership, identities of owners and other required information, interests, compensation or conflicts of the persons required to be disclosed. I understand that failure to comply with this requirement shall constitute a material breach of contract.

H. I hereby declare under penalty of perjury under the laws of Guam that the foregoing is true and correct.

Executed on: 05/07/2024 (date)



Signature of one of the following:
Bidder/Offeror/Prospective Contractor, if a licensed individual
Owner of sole proprietorship Bidder/Offeror/Prospective
Contractor
Partner, if the Bidder/Offeror/Prospective Contractor is a
partnership
Officer, if the Bidder/Offeror/Prospective Contractor is a
corporation

**DECLARATION RE: CONTINGENT FEES
(AG Form 007)**

Pete Pierson

[state name of declarant signing below], hereby declares that:

1. The name of the bidding/offering company or individual is (state name of company)

Federal Contracts Corp

2. As a part of the bidding/offering company's bid or proposal, to the best of my knowledge, the offering company has not retained any person or agency on a percentage, commission, or other contingent arrangement to secure this contract. This statement is made pursuant to 2 GAR Division 4 § 11108(f).

3. As a part of the bidding/offering company's bid or proposal, to the best of my knowledge, the bidding/offering company has not retained a person to solicit or secure a contract with the government of Guam upon an agreement or understanding for a commission, percentage, brokerage, or contingent fee, except for retention of bona fide employees or bona fide established commercial selling agencies for the purpose of securing business. This statement is made pursuant to 2 GAR Division 4 § 11108(f).

4. I make these statements on behalf of myself as a representative of the bidder/offeree, and on behalf of the Bidder/Offerees officers, representatives, agents, subcontractors, and employees.

I hereby declare under penalty of perjury under the laws of Guam that the foregoing is true and correct.

Pete Pierson

Signature of one of the following:

Bidder/Offeree, if the bidder/offeree is an individual; Partner, if the bidder/offeree is a partnership; Officer, if the bidder/offeree is a corporation.

**GOVERNMENT OF GUAM
GENERAL TERMS AND CONDITIONS**

SEALED BID SOLICITATION AND AWARD

Only those Boxes checked below are applicable to this bid.

- [X] 1. **AUTHORITY:** This solicitation is issued subject to all the provision of the Guam Procurement Act (SGCA, Chapter 5) and the Guam Procurement Regulations (copies of both are available at the Office of the Compiler of laws, Department of Law, copies available for inspection at the PORT AUTHORITY OF GUAM). It requires all parties involved in the Preparation, negotiation, performance, or administration of contracts to act in good faith.
- [X] 2. **GENERAL INTENTION:** Unless otherwise specified, it is the declared and acknowledged intention and meaning of these General Terms and conditions for the bidder to provide the Government of Guam (Government) with specified services or with materials, supplies or equipment completely assembled and ready for use.
- [X] 3. **TAXES:** Bidders are cautioned that they are subject to Guam Income Taxes as well as all other taxes on Guam Transactions. Specific information on taxes may be obtained from the Director of Revenue and Taxation.
- WITHHOLDING ASSESSMENT FEE:** All procurements of professional services are subject to a withholding assessment fee for non-resident persons or companies without a valid Guam Business License, which is equal to four percent (4%) of the total dollar value of any contract awarded for all government of Guam contracts for any professional services provided by a non-resident person or company residing outside of Guam, as a cost of doing business with the government of Guam, in accordance with 11 GCA § 71114 (P.L. 33-166).
- [X] 4. **LICENSING:** Bidders are cautioned that the Government will not consider for award any offer submitted by a bidder who has not complied with the Guam Licensing Law. Specific Information on licenses may be obtained from the Director of Revenue and Taxation.
- [X] 5. **NO LOCAL PROCUREMENT PREFERENCE:** There is no geographical preference for this IFB in compliance with 2 CFR § 200.319(c) and the terms and conditions of MARAD FY2022 American Marine Highway (AMH) Grant No.: 693JF72340007; however, no specification, term, condition, or qualification of this IFB shall exclude any Offeror from consideration on the basis of Guam-only experience provided that the experience of such Offeror is otherwise responsive to the solicitation, in accordance with the requirements of 5 GCA § 5008(e).
- [X] 6. **COMPLIANCE WITH SPECIFICATIONS AND OTHER SOLICITATION REQUIREMENTS:** Bidders shall comply with all specifications and other requirements of the Solicitation.
- [] 7. **"ALL OR NONE" BIDS:** NOTE: By checking this item, the Government is requesting all of the bid items to be bid or none at all. The Government will not award on an itemized basis.
- [X] 8. **INDEPENDENT PRICE DETERMINATION:** The bidder, upon signing the Invitation for Bid, certifies that the prices in his bid were derived at without collusion, and acknowledge that collusion and anti-competitive practices are prohibited by law. Violations will be subject to the provision of Section 5651 of that of the Guam Procurement Act. Other existing civil, criminal or administrative remedies are not impaired and may be in addition to the remedies in Section 5651 of the Government code.
- [X] 9. **BIDDER'S PRICE:** The Government will consider not more than two (2) (Basic and Alternate) item prices and the bidder shall explain fully each price if supplies, materials, equipment, and/or specified services offered comply with specifications and the products origin. Where basic or alternate bid meets the minimum required specification, cost and other factors will be considered. Failure to explain this requirement will result in rejection of the bid.
- [X] 10. **BID ENVELOPE:** Envelope shall be sealed and marked with the bidder's name, Bid number, time, date and place of Bid Opening.
- [X] 11. **BID GUARANTEE REQUIREMENT:** Bidder is required to submit a Bid Guarantee Bond or standby Irrevocable Letter of Credit or Certified Check or Cashier's Check in the same bid envelope to be held by the Government pending award. The Bid Guarantee Bond, Letter of Credit, Certified Check or Cashier's Check must be issued by any local surety or banking institution licensed to do business on Guam and made payable to the Treasury of Guam in the amount of fifteen percent (15%) of his highest total bid offer. The Bid Bond must be submitted on Government Standard Form BB-1 (copy enclosed). Personal Checks will not be accepted as Bid Guarantee. If a successful Bidder (contractor) withdraws from the bid or fails to enter into contract within the prescribed time, such Bid guarantee will be forfeited to the Government of Guam. Bids will be disqualified if not accompanied by Bid Bond, Letter of Credit, Certified Check or Cashier's check. Bidder must include in his/her bid, valid copies of a Power of Attorney from the Surety and a Certificate of Authority from the Government of Guam to show proof that the surety company named on the bond instrument is authorized by the Government of Guam and qualified to do business on Guam. For detailed information on bonding matters, contact the Department of Revenue and Taxation. Failure to submit a valid Power of Attorney and Certificate of Authority on the surety is cause for rejection of bid. Pursuant to § GCA § 5212, all competitive sealed bidding for the procurement of supplies or services exceeding \$25,000.00 a 15% Bid Security of the total bid price must accompany the bid package. The bid bond, Letter of Credit, Certified Check or Cashier's Check will serve as Bid Security for this procurement. No award shall be given until bid security is confirmed.
- [X] 12. **PERFORMANCE GUARANTEE:** Bidders who are awarded a contract under this solicitation, guarantee that goods will be delivered or required services performed within the time specified. Failure to perform the contract in a satisfactory manner may be cause for suspension or debarment from doing business with the Government of Guam. In addition, the Government will hold the Vendor liable and will enforce the requirements as set forth in Section 40 of these General Terms and Conditions.
- [X] 13. **SURETY BONDS:** Bid and Bid Bonds coverage must be signed or countersigned in Guam by a foreign or alien surety's resident general agent. The surety must be an Insurance Company, authorized by the government of Guam and qualified to do business in Guam. Bids will be disqualified if the Surety Company does not have a valid Certificate of Authority from the Government of Guam to conduct business in Guam.
- [X] 14. **COMPETENCY OF BIDDERS:** Bids will be considered only from such bidders who, in the opinion of the Government, can show evidence of their ability, experience, equipment, and facilities to render satisfactory service.
- [X] 15. **DETERMINATION OF RESPONSIBILITY OF BIDDERS:** The GENERAL MANAGER reserves the right for securing from Bidders information to determine whether or not they are responsible and to inspect plant site, place of business; and supplies and services as necessary to determine their responsibility in accordance with Section 15 of these General Terms and Conditions.
(2 GAR, Div. 4 § 3116)

- [X] 16. **STANDARD FOR DETERMINATION OF LOWEST RESPONSIBLE BIDDER:**
In determining the lowest responsible offer, the GENERAL MANAGER shall be guided by the following:
- a) Price of items offered.
 - b) The ability, capacity, and skill of the Bidder to perform.
 - c) Whether the Bidder can perform promptly or within the specified time.
 - d) The quality of performance of the Bidder with regards to awards previously made to him.
 - e) The previous and existing compliance by the Bidder with laws and regulations relative to procurement.
 - f) The sufficiency of the financial resources and ability of the Bidder to perform.
 - g) The ability of the bidder to provide future maintenance and services for the subject of the award.
 - h) The compliance with all of the conditions to the Solicitation.
- [X] 17. **TIE BIDS:** If the bids are for the same unit price or total amount in the whole or in part, the GENERAL MANAGER will determine award based on 2 GAR, Div. 4, § 3109(o) (2) or to reject all such bids.
- [X] 18. **BRAND NAMES:** Any reference in the Solicitation to manufacturer's Brand Names and number is due to lack of a satisfactory specification of commodity description. Such preference is intended to be descriptive, but not restrictive and for the sole purpose of indicating prospective bidders a description of the article or services that will be satisfactory. Bids on comparable items will be considered provided the bidder clearly states in his bid the exact articles he is offering and how it differs from the original specification.
- [X] 19. **DESCRIPTIVE LITERATURE:** Descriptive literature(s) as specified in this solicitation must be furnished as a part of the bid and must be received at the date and time set for opening Bids. The literature furnished must clearly identify the item(s) in the Bid. The descriptive literature is required to establish, for the purpose of evaluation and award, details of the product(s) the bidder proposes to furnish including design, materials, components, performance characteristics, methods of manufacture, construction, assembly or other characteristics which are considered appropriate. Rejection of the Bid will be required if the descriptive literature(s) do not show that the product(s) offered conform(s) to the specifications and other requirements of this solicitation. Failure to furnish the descriptive literature(s) by the time specified in the Solicitation will require rejection of the bid.
- [] 20. **SAMPLES:** Sample(s) of item(s) as specified in this solicitation must be furnished as a part of the bid and must be received at the date and time set for opening Bids. The sample(s) should represent exactly what the bidder proposes to furnish and will be used to determine if the item(s) offered complies with the specifications. Rejection of the Bid will be required if the sample(s) do not show that the product(s) offered conform(s) to the specifications and other requirements of this solicitation. Failure to furnish the sample(s) by the time specified in the Solicitation will require rejection of the Bid.
- [] 21. **LABORATORY TEST:** Successful bidder is required to accompany delivery of his goods with a Laboratory Test Report indicating that the product he is furnishing the Government meets with the specifications. This report is on the bidder's account and must be from a certified Testing Association.
- [X] 22. **AWARD, CANCELLATION, & REJECTION:** Award shall be made to the lowest responsible and responsive bidder, whose bid is determined to be the most advantageous to the Government, taking into consideration the evaluation factors set forth in this solicitation. No other factors or criteria shall be used in the evaluation. The right is reserved as the interest of the Government may require to waive any minor irregularity in bid received. The GENERAL MANAGER shall have the authority to award, cancel, or reject bids, in whole or in part for any one or more items if he determines it is in the public interest. Award issued to the lowest responsible bidder within the specified time for acceptance as indicated in the solicitation, results in a bidding contract without further action by either party. In case of an error in the extension of prices, unit price will govern. It is the policy of the Government to award contracts to qualified local bidders. The Government reserves the right to increase or decrease the quantity of the items for award and make additional awards for the same type items and the vendor agrees to such modifications and additional awards based on the bid prices for a period of thirty (30) days after original award. No award shall be made under this solicitation which shall require advance payment or irrevocable letter of credit from the government (2 GAR, Div.4 §1103).
- [] 23. **MARKING:** Each outside container shall be marked with the Purchase Order number, item number, brief item description and quantity. Letter marking shall not be less than 3/4" in height.
- [X] 24. **SCHEDULE FOR DELIVERY:** Successful bidder shall notify the PORT AUTHORITY OF GUAM, Telephone Nos. 477-5931, at least twenty-four (24) hours before delivery of any item under this solicitation.
- [] 25. **BILL OF SALE:** Successful supplier shall render Bills of Sale for each item delivered under this contract. Failure to comply with this requirement will result in rejection of delivery. The Bill of Sale must accompany the items delivered but will not be considered as an invoice for payment. Supplier shall bill the Government in accordance with billing instructions as indicated on the Purchase Order.
- [X] 26. **MANUFACTURER'S CERTIFICATE:** Successful bidder is required, upon delivery of any item under this contract, to furnish a certificate from the manufacturer indicating that the goods meet the specifications. Failure to comply with this request will result in rejection of delivery payment. Supplier shall bill the Government in accordance with billing instructions as indicated on the Purchase Order.
- [X] 27. **INSPECTION:** All supplies, materials, equipment, or services delivered under this contract shall be subject to the inspection and/or test conducted by the Government at destination. If in any case the supplies, materials, equipment, or services are found to be defective in material, workmanship, performance, or otherwise do not conform with the specifications, the Government shall have the right to reject the items or require that they be corrected. The number of days required for correction will be determined by the Government.
- [] 28. **MOTOR VEHICLE SAFETY REQUIREMENTS:** The Government will only consider Bids on motor vehicles which comply with the requirements of the National Traffic and Motor Vehicle safety Act of 1966 (Public Law 89-563) and Clean Air Act as amended (Public Law 88-206), that are applicable to Guam. Bidders shall state if the equipment offered comply with these aforementioned Federal Laws.
- [] 29. **SAFETY INSPECTION:** All motor vehicles delivered under this contract must pass the Government of Guam Vehicle Inspection before delivery at destination.
- [X] 30. **GUARANTEE:**
- a) Guarantee of Vehicle Type of Equipment:

The successful bidder shall guarantee vehicular type of equipment offered against defective parts, workmanship, and performance, for a period of not less than one (1) year after date of receipt of equipment. Bidder shall also provide service to the equipment for at least one (1) year. Service to be provided shall include, but will not be limited to tune ups (change of spark plugs, contact points and condensers) and lubrication (change of engine and transmission oil). All parts and labor shall be at the expense of the bidder. All parts found defective and not caused by misuse, negligence or accident within the guarantee period shall be repaired, replaced, or adjusted within six (6) working days after notice from the Government and without cost to the Government. Vehicular type of equipment as used in this context shall include equipment used for transportation as differentiated from tractors, backhoes, etc.

b) Guarantee of Other Type of Equipment:

The successful bidder shall guarantee all other types of equipment offered, except those mentioned in 30a, above, against defective parts, workmanship, and performance for a period of not less than three (3) months after date of receipt of equipment. Bidder shall also provide service to the equipment for at least three (3) months. All parts found defective within that period shall be repaired or replaced by the Contractor without cost to the Government. Repairs, adjustments or replacements of defective parts shall be completed by the contractor within six (6) working days after notice from the Government.

(c) Compliance with this Section is a condition of this Bid.

- [X] 31. **REPRESENTATION REGARDING ETHICS IN PUBLIC PROCUREMENT:** The bidder or contractor represents that it has not knowingly influenced and promises that it will not knowingly influence a Government employee to breach any of the ethical standards and represents that it has not violated, is not violating, and promises that it will not violate the prohibition against gratuities and kickbacks set forth on Chapter 11 (Ethics in Public Contracting) of the Guam Procurement Act and in Chapter 11 of the Guam Procurement Regulations.
- [X] 32. **REPRESENTATION REGARDING CONTINGENT FEES:** The contractor represents that it has not retained a person to solicit or secure a Government contract upon an agreement or understanding for a commission, percentage, brokerage, or contingent fee, except for retention of bona fide employees or bona fide established commercial selling agencies for the purpose of securing business (GPR Section 11-207).
- [X] 33. **EQUAL EMPLOYMENT OPPORTUNITY:** Contractors shall not discriminate against any employee or applicant of employment because of race, color, religion, sex, or national origin. The contractor will take affirmative action to ensure that employees are treated equally during employment without regards to their race, color, religion, sex, or national origin.
- [X] 34. **COMPLIANCE WITH LAWS:** Bidders awarded a contract under this Solicitation shall comply with the applicable standard, provisions, and stipulations of all pertinent Federal and/or local laws, rules, and regulations relative to the performance of this contract and the furnishing of goods.
- [X] 35. **CHANGE ORDER:** Any order issued relative to awards made under this solicitation will be subject to and in accordance with the provisions of Section 6-101-03.1 of the Guam Procurement Regulations.
- [X] 36. **STOP WORK ORDER:** Any stop work order issued relative to awards made under this solicitation will be subject to and in accordance with the provisions of Section 6-101-04.1 of the Guam Procurement Regulations.
- [X] 37. **CANCELLATION OF INVITATION FOR BIDS OR REQUEST FOR PROPOSALS:** Any Invitation for Bid may be cancelled, or any or all bids or proposals may be rejected in whole or in part as may be specified in the solicitation, when it is in the best interests of the Territory in accordance with regulations promulgated by the Policy Office. The reasons therefor shall be made part of the contract file.
- [X] 38. **TIME FOR COMPLETION:** It is hereby understood and mutually agreed by and between the contractor and the Government that the time for delivery to final destination or the timely performance of certain services is an essential condition of this contract. If the contractor refuses or fails to perform any of the provisions of this contract within the time specified in the Purchase Order (from the date Purchase Order is acknowledged by vendor), then the contractor is in default. Defaults will be treated subject to and in accordance with the provisions of 2 GAR, Div. 4 § 6101(8).
- [X] 39. **JUSTIFICATION OF DELAY:** Bidders who are awarded contracts under this Solicitation, guarantee that the goods will be delivered to their destination or required services rendered within the time specified. If the bidder is not able to meet the specified delivery date, he is required to notify the GENERAL MANAGER of such delay. Notification shall be in writing and shall be received by the GENERAL MANAGER at least twenty-four (24) hours before the specified delivery date. Notification of delay shall include an explanation of the causes and reasons for the delay including statement(s) from supplier or shipping company causing the delay. The Government reserves the right to reject delay justification if, in the opinion of the GENERAL MANAGER, such justification is not adequate.
- [X] 40. **SERVICE-DISABLED VETERAN OWNED BUSINESS PREFERENCE:** Bidding is subject to the policy in favor of Service-Disabled Veteran Owned Business as defined in 5 GCA sections 5011 and 5012.
- [X] 41. **LIQUIDATED DAMAGES:** When the contractor is given notice of delay or nonperformance as specified in Paragraph 1 (Default) of the Termination for Default Clause of this contract and fails to cure in the time specified, the contractor shall be liable for damages for delay in the amount of one-fourth of one percent (1%) of outstanding order per calendar day from date set for cure until either the territory reasonable obtains similar supplies or services if the contractor is terminated for default, or until the contractor provides the supplies or services if the contractor is not terminated for default. To the extent that the contractor's delay or nonperformance is excused under Paragraph 40 (Excuse for Nonperformance or Delayed Performance) of the Termination for Default Clause of this contract, liquidated damages shall not be due the territory. The contractor remains liable for damages caused other than by delay. 2 GAR, Div. 4 §6101(d).
- [X] 42. **PHYSICAL LIABILITY:** If it becomes necessary for the Vendor, either as principal, agent or employee, to enter upon the premises or property of the Government of Guam in order to construct, erect, inspect, make delivery or remove property hereunder, the Vendor hereby covenants and agrees to take, use, provide and make all proper, necessary and sufficient precautions, safeguards and protections against the occurrence of any accidents, injuries or damages to any person or property during the progress of the work herein covered, and to be responsible for, and to indemnify and save harmless the Government of Guam from the payment of all sums of money by reason of all or any such accidents, injuries or damages that may occur upon or about such work, and fines, penalties and loss incurred for or by reasons of the violations of any territorial ordinance, regulations, or the laws of Guam or the United States, while the work is in progress. Contractor will carry insurance to indemnify the Government of Guam against any claim for loss, damage or injury to property or persons arising out of the performance of the Contractor or his employees and agents of the services covered by the contract and the use, misuse or failure of any equipment used by the contractor or his employees or agents, and shall provide certificates of such insurance to the Government of Guam when required.

[X] 43. **INSURANCE COVERAGE REQUIRED:** The amount of insurance required shall be determined by the Port's General Manager depending upon the type of activity conducted, or to be conducted by the owners or operators of vehicles entering the Port's facilities or service providers accessing on foot.

- A. Commercial General Liability including Broad Form Property Damage and Contractual Liability \$1,000,000.00 combined single limit of liability
- B. Worker's Compensation - Statutory
- C. Automobile Liability - \$1,000,000.00 combined single limit of liability

Insurance Company: The insurance coverage(s) must be issued by those insurance companies who are licensed to do business on Guam, as determined by the Insurance Commissioner of the Department of Revenue and Taxation.

Additional Insurance Provision: All Commercial Insurance policies possessed by owners or operators of vehicles entering or using the Port's facilities and/or grounds must name the Port as an additional insured in their policies and specify that the Port shall be given at least thirty (30 days' prior written notice of any cancellation, material change or reduction in coverage.

Proof of Insurance: An Insurance Certificate must be issued listing all the vehicles, equipment, trucks covered under the insurance policy and filed with the Port Police Division. The insurance should include;

Name of the Insured (The Port must be shown as an Additional Insured on all Commercial insurance policies)

- Policy Number
- Effective Date of Policy
- Limits of Insurance
- Description of Coverage Provided; and
- Name of Issuing Company

A certified copy of the Insurance Certificate must be carried in each vehicle, equipment and/or truck entering the Port facilities. This proof of insurance must be provided to the Port Police Division on an annual basis at least ten (10) days before the insurance policy expires.

Notice of Loss: In the event a Port tenant or user is involved in an accident within the Port's facilities or while on Routes 11A or 11B (Cabras Highway) and results in bodily injury or property damage, the Port Police Division must be immediately notified.

Workers' Compensation: All business entities entering or using the Port's facilities must also possess Workers' Compensation Insurance coverage as prescribed by Guam laws and copies of such Certificate of Insurance are to be filed with the Port Police Division. Each certification shall specify that the Port shall be given at least thirty (30) days prior written notice of any cancellation, material change or reduction in coverage.

Interchange Agreement: In lieu of fulfilling the maximum the maximum insurance requirements listed herein, the Port user must provide to the Port a current Interchange Agreement. The primary company must have fulfilled the maximum insurance requirements listed above. The Interchange Agreement must specifically state and name the Port user as additional insured and the duration of coverage. The Port must be notified thirty (30) days prior written notice of any cancellation, materials change or reduction in coverage.

[X] 44. Contract will be cancelled if funds not appropriated or insufficient, and that government will timely inform contractor. 2 GAR, Div.4 §3121(e) (1) (C) and 2 GAR, Div.4 § 3121(e)(1)(D).

[] 45. If cancelled, contractor will be reimbursed unamortized reasonably incurred non-recurring costs. 2 GAR, Div.4 § 3121(e) (1) (G).

[X] 46. **CONTACT FOR CONTRACT ADMINISTRATION:** If your firm receives a contract as a result of this Solicitation, please designate a person whom we may contact for prompt administration.

[X] 47. **WOMEN-OWNED BUSINESS PREFERENCE:** Bidding is subject to the policy in favor of Women-Owned Businesses pursuant to "The Support for Women-Owned Business Act" enacted by Public Law No. 36-26 and codified in 5 GCA section 5013.

[X] 48. **FEDERAL GSA SCHEDULES:** This IFB is federally funded under MARAD FY2022 American Marine Highway (AMH) Grant No.: 693JF72340007. The Port Authority of Guam is accepting Federal GSA pricing inclusive with shipping cost to Guam. If the bid pricing existing on the Federal GSA website from a qualified vendor for qualifying items on the date of opening of the bids, plus the confirmed price of shipping costs to Guam, confirmed after the opening of the bids, is the lowest price, then the contract will be awarded to that vendor.

[X] 49. **SIGNATURES**

This Agreement may be signed by the parties electronically, and in any number of counterparts, each of which shall be deemed an original, but all of which together shall constitute one and the same instrument. Delivery of an executed counterpart by one party to the other may be made by electronic transmission.

Name: Pete Pierson Title: Vice President

Address: 12918 N. Nebraska Ave Telephone: 813-631-0000
Tampa, FL 33612

GOVERNMENT OF GUAM

SEALED BID SOLICITATION INSTRUCTIONS

1. **BID FORMS:** Each bidder shall be provided with one (1) sets of Solicitation forms. Additional copies may be provided upon request. Bidders requesting additional copies of said forms will be charged per page in accordance with 5 GCA § 10203 of the Government Code of Guam. All payments for this purpose shall be by cash, certified check or money order and shall be made payable to the PORT AUTHORITY OF GUAM (EO 86-24).
2. **PREPARATIONS OF BIDS:**
 - 2.0 Bidders are required to examine the drawings, specifications, schedule, and all instructions. Failure to do so will be at bidder's risk.
 - 2.1 Each bidder shall furnish the information required by the Solicitation. The bidder shall sign the Solicitation and print or type his name on the Schedule. Erasures or other changes must be initialed by the person signing the bid. Bids signed by an agent are to be accompanied by evidence of this authority unless such evidence has been previously furnished to the issuing office.
 - 2.2 Unit price for each unit offered shall be shown and such price shall include packing unless otherwise specified. A total shall be entered in the amount column of the Schedule for each item offered. In case of discrepancies between a unit price and extended price, the unit price will be presumed to be correct.
 - 2.3 Bids for supplies or services other than those specified will not be considered. Time, if stated as a number of days, means calendar days and will include Saturdays, Sundays, and holidays beginning the day after the issuance of a Notice to Proceed. Time stated ending on a Saturday, Sunday or Government of Guam legal holiday will end at the close of the next business day.
 - 2.4 No Entitlement To Preparation Costs – the bidder expressly waives any right it may have against the government for any expenses incurred in connection with the preparation of its bid.
3. **EXPLANATION TO BIDDERS:** Any explanation desired by a bidder regarding the meaning or interpretation of the Solicitation, drawings, specifications, etc., must be submitted in writing and with sufficient time allowed for a written reply to reach all bidders before the submission of their bids. Oral explanations or instructions given before the award of the contract will not be binding. Any information given to a prospective bidder concerning a Solicitation will be furnished to all prospective bidders in writing as an amendment to the Solicitation if such information would be prejudicial to informed bidders.
4. **ACKNOWLEDGEMENT OF AMENDMENTS TO SOLICITATIONS:** Receipt of an amendment to a Solicitation by a bidder must be acknowledged by signing an acknowledgement of receipt of the amendment. Such acknowledgement must be received prior to the hour and date specified for receipt of bids.
5. **BID SUBMISSIONS:**
 - a) All Bids and bid documents must be submitted in writing. Bids and modifications thereof shall be enclosed in sealed envelopes if submitting in hardcopy, and addressed to the office specified in the Solicitation. Sealed hard copy bids shall be submitted in a sealed envelope to include one (1) fully executed original and one (1) copy. The outer envelope shall be marked in bold letters, Re-bid for 180' Telescopic Boom Lift (IFB-PAG-013-24). The bidder shall show the hour and date specified in the Solicitation for receipt, the Solicitation number, and the name and address of the bidder or authorized representative on the face of the envelope if submitting in hard copy.
 - b) E-mail submissions of written bids will be accepted. PAG will accept timely electronic submission of Bids by e-mail to the single Point of Contact, Mark A. Cabrera, at ifb.pag.013.24@gmail.com before the time and date for the opening of bids. Bids electronically submitted to any other person through any other method of electronic transmission will not be accepted. If submitting a Bid by e-mail, the subject line of the e-mail transmission shall contain the Bidder's name and the name of the Bidder's authorized representative, along with the following caption: Re-bid for 180' Telescopic Boom Lifts (IFB-PAG-013-24). Bids may be modified or withdrawn by written notice, provided such notice is

is received prior to the hour and date specified for receipt, pursuant to the Guam Procurement Rules & Regulations.

- c) Bids and Bid Documents may be signed by the Bidder electronically, and in any number of counterparts, each of which shall be deemed an original, but all of which together shall be submitted with the Bid and shall constitute the Bid. Failure to submit the required forms in the number or format required may be cause for rejection of Bids due to non-responsiveness.
- d) Samples of items, when required, must be submitted within the time specified, unless otherwise specified by the Government, at no expense to the Government. If not destroyed by testing, samples will be returned at bidder's request and expense, unless otherwise specified by the Solicitation.
- e) Samples or descriptive literature should not be submitted unless it is required on this solicitation. Regardless of any attempt by a bidder to condition the bid, unsolicited samples or descriptive literature will not be examined or tested at the bidder's risk, and will not be deemed to vary any of the provisions of this Solicitation.

6. **FAILURE TO SUBMIT BID:** If no bid is to be submitted, do not return the solicitation unless otherwise specified. A letter or postcard shall be sent to the issuing office advising whether future Solicitations for the type of supplies or services covered by this Solicitation are desired.

7. **LATE BID, LATE WITHDRAWALS, AND LATE MODIFICATIONS:**

- a) Definition: Any bid received after the time and date set for receipt of bids is late. Any withdrawal or modification of a bid received after the time and date set for opening of bids at the place designated for opening is late (Guam Procurement Regulations 2 GAR, Div.4 §3109(k)).
- b) Treatment: No late bid, late modification, or late withdrawal will be considered unless received before contract award, and the bid, modification, or withdrawal would have been timely but for the action or inaction of territorial personnel directly serving the procurement activity.

8. **DISCOUNTS:**

- a) Notwithstanding the fact that prompt payment discounts may be offered, such offer will not be considered in evaluating bids for award unless otherwise specified in the Solicitation. However, offered discounts will be taken if payment is made within the discount period, even though not considered in the evaluation of bids.
- b) In connection with any discount offered, time will be computed from date of delivery and acceptance of the supplies to the destination as indicated in the purchase order or contract. Payment is deemed to be made for the purpose of earning the discount on the date of mailing of the Government check.

9. **GOVERNMENT FURNISHED PROPERTY:** No material, labor or facilities will be furnished by the Government unless otherwise provided for in the Solicitation.

10. **SELLER' INVOICES:** Invoices shall be prepared and submitted in quadruplicate (one copy shall be marked "original") unless otherwise specified. Invoices shall be "certified true and correct" and shall contain the following information: Contract and order number (if any), item numbers, description of supplies or services, sizes, quantities, unit prices, and extended total. Bill of lading number and weight of shipment will be shown for shipments made on Government bills of lading.

11. **RECEIPT, OPENING AND RECORDING OF BIDS:** Bids and modifications shall be publicly opened in the presence of one or more witnesses, at the time, date, and place designated in the Invitation for Bids. The name of each bidder, the bid price, and such other information as is deemed appropriate by the Procurement Officer, shall be read aloud and recorded, or otherwise made available. The names and addresses of required witnesses shall be recorded at the opening. The opened bids shall be available for public inspection except to the extent the bidder designates trade secrets or other proprietary data to be confidential as set forth in accordance with Section 12, below. Material so designated shall accompany the bid and shall be readily separable from the bid in order to facilitate public inspection of the non-confidential portion of the bid. Prices, makes and models or catalogue numbers of the items offered, deliveries, and terms of payment shall be publicly available at the time of bid opening regardless of any designation to the contrary (Guam Procurement Regulations 2 GAR, Div.4 §3109(k)).

12. **CONFIDENTIAL DATA:** If a bidder considers any information submitted in its bid to be confidential, the bidder must identify in writing to the Government those portions which it considers confidential, and must request in writing that those portions be kept confidential. Only trade secrets and proprietary data will be considered confidential. If there is a request for confidentiality, the Government will render a decision on the request as soon as practicable after bids are opened. The Government will advise any bidder requesting confidentiality, of the Government's decision in writing. If the Government does not agree with a bidder's request, then the Government will inform the bidder that it may lodge a protest regarding any part of the Government's decision by following the procedure for protests outlined in Chapter 9 of the Guam Procurement Regulations.

13. **PROHIBITION AGAINST GRATUITIES AND KICKBACKS:** With respect to this procurement and any other contract that bidder may have or wish to enter into with the Government, the bidder represents that he/she has not violated, is not violating, and promises that he will not violate the prohibition against gratuities and kickbacks set forth in the Guam Procurement Regulations.

14. **STATEMENT OF QUALIFICATIONS:** The ability capacity and skill of the Bidders to perform; Whether the bidder can perform promptly or within the specified time; The quality of performance of the Bidder with regards to awards previously made to him; The sufficiency of the financial resources and ability of the bidders to perform; and the compliance with all of the conditions to the solicitation.

15. **WAGE AND BENEFIT COMPLIANCE-CONTRACTORS PROVIDING SERVICES**

a) Contractor with regard to all person its employs whose purpose in whole or in part is the direct delivery of services contracted for with the Government of Guam in this procurement, shall pay such employees in accordance with the Wage Determination for Guam and the Northern Marianas Islands issued and promulgated by the U.S. Department of Labor for such labor as is employed in the direct deliverance of deliverables to the government of Guam. 5 GCA § 5801 Contractor shall be responsible for flowing down this obligation to its subcontractors.

b) The Wage Determination most recently issued by the U.S. Department of Labor at the time this Agreement was awarded to Contractor shall be used to determine wages and benefits which shall be paid to employees pursuant to this clause. 5 GCA § 5801

c) Should any contract contain a renewal clause, then at the time of renewal adjustments there shall be stipulations contained in that contract for applying the Wage Determination, so that the Wage Determination promulgated by the U.S. Department of Labor on a date most recent to the renewal date shall apply. 5 GCA § 5801

d) In addition to the Wage Determination detailed above, health and similar benefits for employees having a minimum value as detailed in the Wage Determination issued and promulgated by the U.S. Department of Labor shall apply. Contractor shall pay a minimum of ten (10) paid holidays per annum per employee. 5 GCA § 5802

e) Any violation of Contractor or its subcontractor's obligations of this section shall be investigated by the Guam Department of Labor and may include a monetary penalty assessment by the Guam Department of Labor of no less than One Hundred Dollars (\$100.00) per day, and no more than One Thousand Dollars (\$1,000.00) per day, until such time as a violation has been corrected, as well as the payment of all back wages and benefits due. 5 GCA § 5803

f) In addition to any and all other breach of contract actions the Government of Guam may have under this procurement, in the event there is a violation in the process set forth in subsection (e) above, Contractor may be placed on probationary status by the GENERAL MANAGER of the General Service Agency, or its successor, for a period of one (1) year.

During the probationary status, a Contractor shall not be awarded any contract by any instrumentality of the Government of Guam. A Contractor who has been placed on probationary status, or has been assessed a monetary penalty pursuant to 5 G.C.A. Article 13 Title 5 may appeal such penalty or probationary status to the Superior Court of Guam. 5 GCA § 5804

g) Contractor along with all proposed Offerors and submitter under this procurement were required to submit a Declaration of Compliance with Wage Determination laws as part of this procurement

with a copy of the most recent Wage Determination for Guam and the Northern Marianas Islands issued and promulgated by the U.S. Department of Labor. 5 GCA §5805

- h) The applicable USDOL Wage Determination Rate Revision (as defined by subsections (b) and (c)) is to this Agreement. Contractor agrees to provide upon written request by the Government of Guam written certification of its compliance with its obligations as part of each invoice, along with the names of any employees, their positions, and detailed wage and benefits paid in keeping with this section. Additionally, upon request by Government of Guam the Contractor shall submit source documents as to those individuals provide direct services in part or whole under this Agreement and its payments to them of such wages and benefits.

16. **ETHICAL STANDARDS:** With respect to this procurement and any other contract that the Contractor may have, or wish to enter into, with any government of Guam agency, the Contractor represents that it has not knowingly influenced, and promises that it will not knowingly influence, any government employee to breach any of the ethical standards set forth in the Guam Procurement Law and in any of the Guam Procurement Regulations.

17. **PROHIBITION AGAINST CONTINGENT FEES:** The Contractor represents that he has not retained any person or agency upon an agreement or understanding for a percentage, commission, brokerage, or other contingent arrangement, except for retention of bona fide employees or bona fide established commercial selling agencies, to solicit or secure this Agreement or any other contract with the government of Guam or its agencies.

18. **CONTRACTOR'S WARRANTY AS TO EMPLOYEES AND SEX OFFENSES.** Reference 5 GCA 5253 (b) Contractor warrants that no person providing services on behalf of the Contractor has been convicted of a sex offense under the provisions of Chapter 25 of Title 9 of GCA or an offense as defined in Article 2 of Chapter 28, Title 9 GCA, or an offense in another jurisdiction with, at a minimum, the same elements as such offenses, or who is listed on the Sex Offender Registry.

Contractor warrants that if any person providing services on behalf of Contractor is convicted of a sex offense under the provisions of Chapter 25 of Title 9 GCA, or an offense as defined in Article 2 of Chapter 28, Title 9 GCA, or an offense in another jurisdiction with, at a minimum, the same elements as such offenses, or who is listed on the Sex Offender Registry, that such person will be immediately removed from working at said agency and that the administrator of said agency be informed of such within twenty-four (24) hours of such conviction. Any contractor found in violation of this section, after notice from the Government of Guam, after notice from the contracting authority of such violation, shall within twenty-four (24) hours, take corrective action and shall report such action to the contracting authority. Failure to take corrective action with the stipulated period may result in the temporary suspension of the contract at the discretion of the Government of Guam.

19. **POLICY IN FAVOR OF SERVICE-DISABLED VETERAN OWNED BUSINESSES** P.L. 31-115 (September 20, 2011) 5 GCA § 5011 and § 5012 In the procurement of any supply or service, (except for professional services), if such supply or service is offered by a Service-Disabled Veteran Owned Business "SDVOB", as defined in 5 GCA § 5012, that is at least fifty one percent (51%) owned by service-disabled veteran(s), and if the supply or service is available within the period that is required for the procurement, and the price for the supply or service does not exceed one hundred five percent (105%) of the lowest bidder price, a preference shall be given to that SDVOB by the Government of Guam, and the supply or service shall be purchased from said SDVOB. This shall be in addition to any other procurement benefit the SDVOB may qualify for under Guam law. A business concern is a qualified SDVOB if: (a) the business concern is licensed to do business on Guam; (b) the business concern maintains its headquarters on Guam; (c) the business concern is at least fifty-one (51%) owned by a service-disabled veteran(s) who served in the active U.S. military service, was discharged or released under honorable conditions and whose disability is service-connected as demonstrated by a DD214, and certified by an award letter from the U.S. Department of Veterans Affairs; the DD214 and Disability award letter from U.S. Department of Veterans Affairs are submitted to the Government of Guam procuring agency for every service offered; and the service disabled veteran(s) owner(s) of the business concern has filed individual tax returns on Guam for a period of at least three (3) consecutive years.

20. **Policy In Favor of Women-Owned Businesses.** (a) Notwithstanding any other provision of law, if any entity of the government of Guam or any entity expending governmental funds intends to procure any

supply or service which is offered by a business concern that is at least fifty-one percent (51%) owned by women, that entity shall procure such supply or service from that business concern if the supply or service is available within the period required by the procuring entity and the price for the supply or service does not exceed one hundred five percent (105%) of the lowest price bidder, and shall be in addition to any other procurement benefit the women-owned business may qualify for under Guam law. The procuring entity shall determine the lowest price to the entity in the case of more than one (1) women-owned business, or a women-owned business and a service-disabled veteran owned business, who are competing for the same government contract. (b) Qualifications of a Women-Owned Business. A business concern is qualified under Subsection (a) of this Section if: (1) the business concern is licensed to do business on Guam; (2) the business concern maintains its headquarters on Guam; (3) the business concern is at least fifty-one percent (51%) owned by women, who manage day-to-day operations and make long-term decisions; (4) the business concern is certified as a Women-Owned Small Business (WOSB) or an Economically Disadvantaged Women-Owned Small Business (EDWOSB) by the U.S. Small Business Administration; and (5) the owner(s) of the business concern has (have) filed individual tax returns on Guam for a period of at least three (3) consecutive years.

ITEM NO.	DESCRIPTION	QUANTITY	UNIT	UNIT PRICE	EXTENSION
1.1	Telescopic Boom Lift, 180' Reach Full time 4WD	1	EA.	\$ 517,205.41	\$ 517,205.41

GENERALS: These specifications have been written, to describe minimum equipment and performance requirements to be supplied by the equipment manufacture bidding. Reasonable test may be conducted upon delivery before acceptance.

The successful bidder shall furnish all necessary and desirable information and instructions for the proper operation of the equipment.

The government reserves the right to accept and/or reject any and all bids, to waive any defects, irregularities, or specification discrepancies and to award the bid as council deems to be in the best interest of the government.

DISCREPANCIES

LISTED: Should any bidder have deviations from these specifications in his bid and cannot meet every requirement of the specifications, he shall submit a letter and attach it to the bid, explaining the deviations, failure to do so will cause the bid to be rejected as being non-responsive.

DELIVER: The successful bidder shall deliver one (1) 180' Boom Lift each be new fully assembled and ready for operation to the Port Authority of Guam within 120 days.

SPECIFICATIONS:

BIDDING AND OR REMARKS:

Engine:	74 hp minimum, Diesel Engine Engine shutoff protection system (Low Oil Pressure, High Engine Temperature High Transmission Temperature)	<u>comply</u>
Fuel Type:	Diesel (Ultra Low Sulfur) Tier IV	<u>comply</u>
Fuel Tank:	The fuel tank furnished shall be Min. 60 gallon	<u>exception - 45 gallon</u>
Platform reach:	180ft & 10ft jib	<u>comply, 13' jib</u>
Platform Dimensions:	36 x 96 with railing & side entry	<u>comply</u>
Platform Capacity:	Unrestricted - 500 lbs	<u>comply</u>
	Restricted - 750 lbs	<u>comply - 1,000 pounds</u>
Platform Rotation:	160 degrees	<u>comply - 173 degrees</u>
Swing:	360 degrees continuous	<u>comply</u>
Steering:	Selectable Steering (ground level or platform)	<u>exception - ground control steering select not available - platform only</u>
Axles:	Extendable front and rear	<u>comply</u>
Gauges:	Air, Fuel, Hour, Volt, Temp, and Oil	<u>exception - status lights only</u>
Lights:	2 Headlights in facing forward with protective guard, 2 Headlights facing rear with protective guard. 2 work lights on platform	<u>exception - quoted are platform worklights, headlights, and red tail lights</u>
Tires:	Protector Lug Foam Filled tires	<u>comply</u>
Manlift Accessories:	Platform to be plumbed with air lines for use of pneumatic Tools	<u>comply</u>
	Hostile Weather/Environment Kit	<u>comply</u>
	AC plug/outlet in platform	<u>comply</u>

Accessories: Standard manufacture accessories to include
 Horn - Electric comply
 Amber strobe light, key switch "on position" activated. comply
 Mounted 5 lbs. fire extinguisher on platform comply - 20 pound
 1 set "Shop Type" repair manuals and complete digital files available at www.jlg.com
 illustrated parts manual. hand held analyzer available from JLG parts
 Diagnostic and Troubleshooting software comply
 Owner/Operator manual for each equipment digital files available at www.jlg.com
 Maintenance and Service manual for each equipment warranty statement is attached
 Warranty booklet for each equipment included in digital parts manual
 Recommended spare parts list comply
 All fluids to the fullest level filled in accordance with shipping regulations
 Fuel tank to be loaded with 10 gallons of diesel. comply
 Electronic Backup alarm comply
 Engine shut-off protection system (Low Oil Pressure, comply
 High Engine Temperature and High Transmission comply
 Temperatures), not available
 Reflective Conspicuity Tape
 Electronic rust prevention system

Receiving Date: (Acceptance Date) will be Three (3) days after delivery Date, provided the Equipment is Delivered Completely Assembled and meets all specifications, terms and conditions of the bid requirements.

comply

Special Provision: If parts catalog and maintenance repair comes in CD-ROM or Microfiche, bidder must supply to requesting agency. Bidder must still provide hard (book) copy to the requesting agency.

hard copy operators manual provided digital file of other manuals available for no charge at www.jlg.com

Applicable Federal Laws And Regulations: Buy American Act – 41 U.S.C § 8301-8305
 Build America Buy America Act Certificate must be provide by the manufacture.

country of origin is US certificate of origin is available upon request Build America Buy America Act Certificate not available

Training: Provide 2 sessions on pre inspection, post inspection and safe operational procedures for all operators, leaders, supervisors and dispatchers within Maintenance division.

not available

Warranty: Manufacturers Standard Warranty, 1 year limited warranty. Service of one (1) year/ 2,000 hours, all parts, labor and oil disposal shall be included at "No Cost to the Government".

Yes, offer as requested.

standard JLG commercial warranty applies - see attached warranty statement oil disposal not included

No, Offer the following:

The manufacturer Warranty and Boucher shall be specified on items covered and provided in the bid packet. (Bid submission received without written warranty and Boucher as specified will be rejected).

Yes, offer as requested.

warranty statment is attached - requirement for "Boucher" is unclear

No, Offer the following:

The successful bidder shall provide technical assistance and warranty administration without any cost to "The Port Authority of Guam"

[] Yes, offer as requested. _____

[X] No, Offer the following: Terms and conditions of JLG standard commercial warranty apply.

The successful bidder shall provide service, such as to determine deficiency, repair or adjustment of the equipment on government premises or transfer the equipment to the shop where the repair should be done, at anytime within the warranty period and at "No cost to the Government". When the equipment is down for warranty repair(s) and remain in shop for a certain period awaiting part(s) and or material(s), the total down-time period shall be extended to the service and warranty period.

[] Yes, offer as requested. _____

[X] No, Offer the following: Terms and conditions of JLG standard commercial warranty apply.

The manufacture shall have a local authorized dealer who can provide factory trained service technician(s). Bidder shall provide certification of factory trained technician(s) for the above equipments be purchased during commissioning. Failure to provided will result as "Unacceptable".

[] Yes, offer as requested. _____

[X] No, Offer the following: Technical phone support is available at no charge.

Provide Complete Familiarization Training to Port Representatives on maintenance of Mechanical, Electrical and Hydraulic systems on units by manufacturer. All costs Associated with training (airfare, lodging and transportation) are to be included At no cost to the Government of Guam.

[] Yes, offer as requested. _____

[X] No, Offer the following: Not available.

This project is funded under ther Fiscal Year 2022 America's Marine Highway (AMH) Program Grant No.: 693JF72340007

Certification requirements for procurement of steel, iron, construction materials, or manufactured products.
If steel, iron, construction materials, or manufactured products (as defined in § 70914(a) of the Build America, Buy America Act, Pub. L. No. 117-58, div. G, tit. IX, subtit. A, 135 Stat. 429, 1298 (2021) and Office of Management and Budget (OMB) Memorandum M-22-11, "Initial Implementation Guidance on Application of Buy America Preference in Federal Financial Assistance Programs for Infrastructure." as implemented by MARAD through Term B.5 of the exhibits to the agreement) are being procured, the same or equivalent certificate as set forth below shall be completed and submitted by each bidder or offeror in accordance with the requirement contained in section 2.1 of the agreement.

Certificate of Compliance with Buy America Requirements

The bidder or offeror hereby certifies that it will comply with the requirements of § 70914(a) of the Build America, Buy America Act, Pub. L. No. 117-58, div. G, tit. IX, subtit. A, 135 Stat. 429, 1298 (2021), as implemented by MARAD in Term B.5 of the exhibits to the grant agreement.

Date 05/07/2024

Signature _____

Company Federal Contracts Corp

Name Pete Pierson

Title Vice President

Certificate of Non-Compliance with Buy America Requirements

The bidder or offeror hereby certifies that it cannot comply with the requirements of § 70914(a) of the Build America, Buy America Act, Pub. L. No. 117-58, div. G, tit. IX, subtit. A, 135 Stat. 429, as implemented by MARAD in Term B.5 of the exhibits to the grant agreement, but it may qualify for an exception to the requirement pursuant to § 70914(b) of the Build America, Buy America Act and Term B.5.

Date 05/07/2024

Signature _____

Company Federal Contracts Corp

Name Pete Pierson

Title Vice President

Notes: Bidder shall identify on their bids, any deviations from the specifications or requirements in the remarks column and state the item being offered for evaluation processing. Failure to comply may result in the rejection of the bid.

A certificate of origin is required on the sale of equipment.

Equipment must be delivered to the Port Authority of Guam for inspection

Bidding on : Telescopic Boom Lift 180' reach, Full time 4WD

MANUFACTURER:	JLG industries, Inc.
MAKE:	JLG
MODEL:	1850SJ
YEAR:	2024
PLACE OF ORIGIN:	USA
DATE OF DELIVERY:	150 days after receipt of order

These specifications have been developed by Port Authority of Guam's, Raymond B. Santos- Transportation Superintendent, Joaquin P. Pangelinan- Equipment Service Support Manager, reviewed by Glenn B. Nelson- Operations Manager, Dominic G. Muna- DGMO, Pacifico Martir- DGMA, and approved by Rory J. Respicio- General Manager

DIMENSIONS

REACH DIAGRAM

All dimensions are approximate

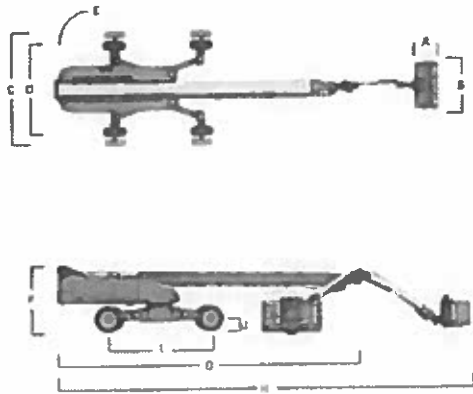

A. Platform Width	16-in / 413-mm
B. Platform Length	75-in / 1.91-m
C. Machine Width - Axes Extended	16-ft 6-in / 5.0-m
D. Machine Width - Axes Retracted	8-ft 7-in / 2.61-m
E. Tailswing	2-ft 4-in / 732-mm
F. Machine Height	10-ft / 3.05-m
G. Machine Length - Stowed	47-ft 9.5-in / 14.57-m
H. Machine Length - Overall	63-ft 10-in / 19.45-m
I. Wheelbase	17-ft 1.5-in / 5.22-m
J. Ground Clearance	135-in / 34.15-m - Axle 157-in / 40.00-m - Chassis

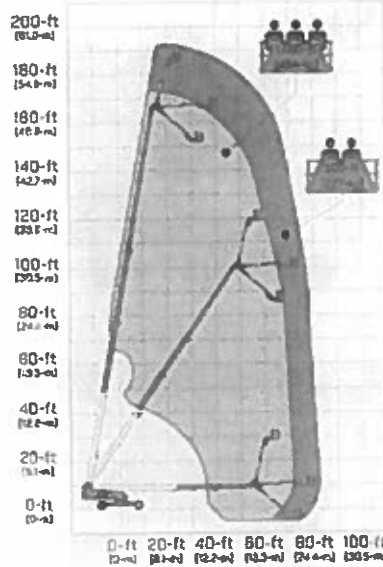

We provide coverage for one (1) full year and cover all warranted major structural components for five (5) years. Due to continuous product improvements, we reserve the right to make operational and/or equipment changes without prior notification. This machine meets or exceeds applicable ANSI and CSA requirements based on machine and jurisdiction as defined in the manufacturer's literature for intended applications. Please reference the serial number plate on the machine for additional information.

Part No. 301020 | 80271.00



JLG INDUSTRIES, INC.
Call Free US 1-877-JLG-4-171
jlg.com

An Oshkosh Corporation Company



12918 N. Nebraska Ave.
 Tampa, FL 33612
 UEI: TK67EL9NPMD9
 Cage Code: 3VCK4
 FEIT: 42-1613127
 DUNS: 094261935

POC: Mark A. Cabrera
 TO: Port Authority of Guam

Sales Quote IFB-PAG-013-24
 Date: 5/7/2024

GSA Contract No.
 GS-03F-113DA

Phone: 671-477-5931 ext. 252
 E-Mail macabrera@portofguam.com

Certs: SDVOSB, HUBZone SB

Qty.	Manufacturer	Item No.	Description	Unit Price	Total Price
1	JLG	1850SJ	Telescopic Boom Lift	\$458,543.67	\$458,543.67
1		FREIGHT	Freight- Sales	\$38,800.00	\$38,800.00
1		FCC03	Misc Charges - 4% Tax	\$19,861.74	\$19,861.74

FOB: Destination
 Delivery Time: 365 Days ARO

JLG 1850SJ, USA ANSI 92.20, USA SPEC, DEUTZ ENGINE
 T4F (STEEL HOODS), J BOOM, 4 WHEEL DRIVE,
 IN455/50D710 FF TIRES, 4 WHEEL STEER, PLATF 36X96 SE,
 SWING GATE,LSS, *1/2" AIRLINE, FIXED AXLE,
 *PLATFORM WORKLIGHTS, *HEAD,TAIL LIGHTS PACKAGE,
 ENGLISH DECALS, SKYLINE (STD), *HOSTILE PACKAGE,
 CREAM PAINT W/ORANGE TRIM, *FIRE EXTINGUISHER (20LB)

*FREIGHT TO GUAM INCLUDED

PLEASE NOTE:

- Customer is responsible for any taxes and duties to get the unit released at the port.
- JLG does not have an authorized service center on the island of Guam.
 Any fees required to ensure aftermarket support in this region are not included in this pricing.
- Machine complies to Buy American Build Act.
- The 7,500-watt SkyPower generator is commonly ordered on this model but was not listed as a requirement, so is not included in this pricing.
- Amber strobe is standard.
- Model is 1850SJ, Not 1850SJP

Subtotal: \$517,205.41
 Tax: \$0.00
Total: \$517,205.41

Pete Pierson, Vice President
 O. (813)631-0000
 F. (813)631-0008
 pete@federalcontractscorp.com



12918 N. Nebraska Ave.
Tampa, FL 33612
UEI: TK67EL9NPM9
Cage Code: 3VCK4
FEIT: 42-1613127
DUNS: 094261935

POC: Mark A. Cabrera
TO: Port Authority of Guam

Sales Quote IFB-PAG-013-24
Date: 5/7/2024

GSA Contract No.
GS-03F-113DA

Phone: 671-477-5931 ext. 252
E-Mail macabrera@portofguam.com

Certs: SDVOSB, HUBZone SB

Terms and Conditions:

- Quote valid for 30 days
- Terms: Net 30
- Unless otherwise specified, full dock or off-loading capabilities required to avoid additional charges.
- If using a purchase card, a credit card surcharge may apply.
- Certificate of Origin/MSO will not be released until payment in full has been received.

Pete Pierson, Vice President
O. (813)631-0000
F. (813)631-0008
pete@federalcontractscorp.com

1850SJ

TELESCOPIC ULTRA BOOM

BOOM LIFT

JLG



KEY SPECS

Platform Height

185-ft 7-in / 56.56-m

Drive Speed

2.8 mph / 4.5 km/h

Horizontal Outreach

80-ft / 24.38-m

Platform Capacity

1,000-lb / 454-kg - Restricted
500-lb / 227-kg - Unrestricted

KEY FEATURES

- Expansive work area of a maximum platform height of 185-ft and a telescoping jib that provides 2.9 million cubic feet of work area.
- Optimized maneuverability with full-time four-wheel drive to traverse over rough terrain.
- Enhanced Platform Controls - An LCD screen shows operators where they are in the work envelope, along with other useful information.
- Single sensor load sensing system features fewer parts and requires no weight to calibrate.

ACCESSORIES & OPTIONS

- Accessory Packages:
 - SkyWelder® Package
 - SkyPower® Package
 - SkyGlazier® Package
- Additional Platform Options
 - Fall Arrest, Rear Entry - 36 x 96-in
 - Drop Bar - 30 x 36-in, 36 x 96-in
 - Inward Self-Closing Swing Gate - 36 x 72-in, 36 x 96-in
 - Tri-Entry, Drop Bar - 36 x 72-in, 36 x 96-in
 - Tri-Entry, Swing Gate - 36 x 72-in, 36 x 96-in
 - Amber Beacon
 - Ambient White Noise Alarm
 - Bolt On Fall Arrest System
 - ClearSky™ Telematics
 - Cold Package Plus¹
 - Cold Weather Start Kit²
 - Hostile Environment Kit³
 - Light Package⁴
- Platform Mesh, Bolt On
 - Mesh to Top Rail, Plastic or Aluminum
 - Mesh to Mid Rail, Plastic or Aluminum
- SkySense® Enhanced Detection System
- Soft Touch System
- Special Hydraulic Oils
- Platform Storage Tray, Center or Corner

STANDARD SPECIFICATIONS

Performance

Platform Height	185-ft 7-in / 56.56-m
Horizontal Outreach	80-ft / 24.38-m
Swing	360 Degrees Continuous
Platform Capacity (Restricted)	1,000-lb / 454-kg
Platform Capacity (Unrestricted)	500-lb / 227-kg
Platform Rotator	173 Degrees Hydraulic
Jib Length (Retracted/Extended)	13-ft (3.96-m) / 20-ft (6.1-m)
Jib Range of Articulation	120 Degrees (+75, -45)
Weight*	59,900-lb / 27,170-kg
Max. Ground Bearing Pressure	119.6 psi / 8.41 kg/cm ²
Drive Speed	2.8 mph / 4.5 km/h
Gradeability	40%
Tilt Cut Out	5 Degrees
Turning Radius (Inside):	
Axles Retracted/Extended	23-ft 4-in (7.12-m) / 7-ft 7-in (2.3-m)
Turning Radius (Outside):	
Axles Retracted/Extended	31-ft 3-in (9.52-m) / 21-ft 8-in (6.6-m)

*Certain options or country standards increase weight

Engine

Diesel Engine - Deutz TCD 3.6L Tier IV F	99.8 hp / 74.4 kW
Fuel Tank Capacity	45 gal / 170 L

Tires

Standard	445/50D710 Foam-filled
----------	------------------------

Hydraulic System

Capacity	75.1 gal / 284.2 L
----------	--------------------

STANDARD FEATURES

- 12V-DC Auxiliary Power
- 173 Degrees Hydraulic Platform Rotator
- 3 Selectable Steering Modes
- AC Receptacle in Platform
- All Motion Alarm
- Control ADE® System
- Drive-Out Extendable Axles
- Engine Distress Warning/Shutdown—Selectable via JLG Analyzer
- Full-Time 4WD
- Glow Plugs
- Gull-Wing Steel Hoods
- Hourmeter
- Lifting/Tie Down Lugs
- Load Sensing System
- LCD Panel at Operator's Platform Control Console
- Platform 36 x 96-in (91 x 2.44-m) Side Entry
- Proportional Controls
- Platform Console Machine Status Light Panel*
- Selectable Capacity Envelope
- Swing-Out Engine Tray
- SkyGuard SkyLine™
- Tilt Light and Alarm

1. Includes extreme cold engine oil, fuel conditioner, engine block heater, battery blanket, glow plugs, hydraulic tank heater, and oversized footswitch.

2. Includes battery heater and oil tank heater.

3. Includes console cover, boom wipers and cylinder bellows.

4. Includes platform work lights, head and tail lights, amber beacon.

* Provides indicator lights at platform control console for system distress, fuel level, low fuel, 5 degree tilt light and foot switch status.

Additional accessories and options available via JLG Aftermarket

Shown with Optional Mesh to Top Rail

1850SJ

ULTRA BOOM

BOOM LIFT



DIMENSIONS

REACH DIAGRAM

All dimensions are approximate

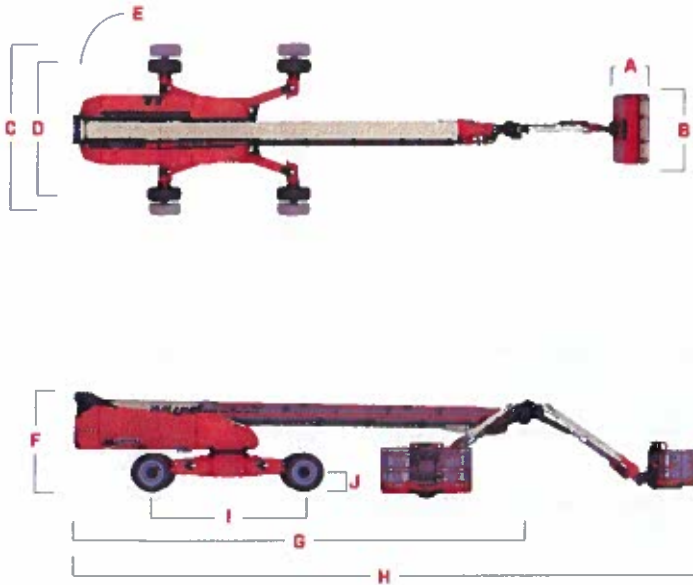

A. Platform Width	36-in / 91-cm
B. Platform Length	96-in / 2.44-m
C. Machine Width - Axles Extended	16-ft 6-in / 5-m
D. Machine Width - Axles Retracted	8-ft 2-in / 2.49-m
E. Tailswing	7-ft 7-in / 2.32-m
F. Machine Height	10-ft / 3.05-m
G. Machine Length - Stowed	47-ft 9.5-in / 14.57-m
H. Machine Length - Overall	63-ft 10-in / 19.45-m
I. Wheelbase	17-ft 1.5-in / 5.22-m
J. Ground Clearance	13.5-in / 34-cm - Axle 16.25-in / 41-cm - Chassis

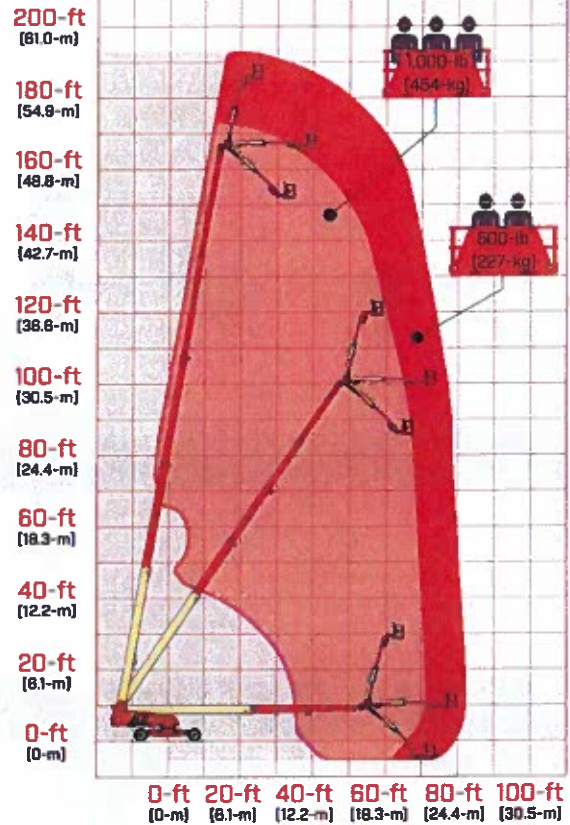

We provide coverage for one (1) full year, and cover all specified major structural components for five (5) years. Due to continuous product improvements, we reserve the right to make specification and/or equipment changes without prior notification. This machine meets or exceeds applicable ANSI and CSA requirements based on machine configuration as originally manufactured for intended applications. Please reference the serial number plate on the machine for additional information.



JLG INDUSTRIES, INC.
Toll-free US 877-JLG-LIFT
JLG.com

An Oshkosh Corporation Company

JLG NEW PRODUCT WARRANTY AMERICAS

JLG Industries, Inc. ("JLG") warrants its new products made by it to be free from defects in material or workmanship for twelve (12) months from the warranty start date.

In addition, JLG further warrants the structural elements of each new Boom Lift, Scissor Lift, Vertical Mast, Telehandler, Power Tower, Trailer, and Trailer Boom (JLG LiftPod product excluded) made by it, as defined in its then current warranty policies and procedures, to be free from defects in material or workmanship for five (5) years from the warranty start date.

JLG further warrants the powertrain of each of the new telescopic handlers made by it, as defined in its then current warranty policies and procedures, to be free from defects in material and workmanship for twenty-four (24) months or 2,000 hours, whichever occurs first.

JLG agrees only to repair or replaced at its own expense, F.O.B. (E.X.W.), the place or places of manufacture, any part or parts of the product found to be defective in material or workmanship, provided JLG is notified of such defect or defects within the applicable warranty period and given a reasonable time to correct the defect. In no case shall any warranty extend to defects in materials, components, or services furnished by third parties. Defects caused by chemical action or the presence of abrasive materials and defects arising following the operation beyond rated capacity or the improper use or application of any products shall not be considered defects within the scope of this warranty. If any repairs or alterations are made or any parts are replaced during the applicable warranty periods by anyone other than JLG or an entity authorized by JLG in accordance with authorized JLG service manuals or with parts, accessories, or attachments other than authorized by JLG for use in its products, customer shall pay for such repairs or parts without recourse against JLG, and JLG shall be relieved of responsibility for fulfillment of this warranty with respect to such repairs, alterations, or replacements so made. JLG's obligations under this warranty shall at all times be subject to its then current warranty policies and procedures. The above-mentioned warranty shall not apply to replacement or service parts made and sold to a customer by JLG. Routine maintenance, routine maintenance items (including paint and decals), and minor adjustments are excluded from this warranty. Certain components, including, but not limited to, engines, tires, and batteries, which may be a part of the product are not manufactured or warranted by JLG. Any applicable warranty for such components is provided through the original manufacturer of the component or its distributor organization.

JLG further warrants that each unit is designed, built, and equipped to meet United States Environmental Protection Agency ("EPA") and, where applicable, California Air Resources Board ("CARB") emissions requirements in effect on the date of manufacture. JLG further warrants that the unit is free from defects in material and workmanship that might prevent the unit from meeting applicable EPA and CARB requirements. Policy holders may obtain such emissions warranty service at no cost, including parts, labor, and diagnostic services, for their equipment from an authorized JLG Servicer or any authorized servicer of the Engine OEM. Please also note that this Emissions Control System Warranty is required by EPA, and in certain equipment applications, by CARB, and is a distinct and additional warranty from the general commercial warranty described herein that JLG and its engine suppliers provide to customers who purchase JLG equipment and associated engines. Please refer to the "JLG Emissions Warranty Guidelines," available for download at www.JLG.com, for additional details specific to your machine. End users may also perform their own repairs of emissions-related components, although the cost of labor and diagnostic services provided by other than an authorized JLG servicer or OEM are outside the scope of this warranty and will not be paid for by JLG free of charge. The proper performance of routine maintenance by the customer or a third-party service shall not invalidate this emissions warranty.

JLG NEW PRODUCT WARRANTY NORTH AMERICA

JLG Warranty Policy covers Parts, Labor, and Travel costs as outlined in JLG's then current warranty policies and procedures. JLG LiftPod Product is excluded from Travel coverage.

JLG Warranty Policy does not cover any duties, taxes, environmental fees, including without limitation, disposal or handling of tires, batteries, and petrochemical items.

Under no circumstances shall JLG be liable for any consequential or special damages which any person or entity may incur or claim to incur as a result of any defect in the product or in any correction or alteration thereof made or furnished by JLG or others. "Consequential" or "special damage" includes, but is not limited to costs of transportation, lost sales, lost orders, lost profits, lost income, increased overhead, labor and material costs, and cost of manufacturing variances and operational inefficiencies. JLG's maximum liability under this warranty shall be the purchase price paid to JLG with respect to the product to which such warranty is claimed. The limitation of liability provisions herein shall apply to any and all claims or suits brought against JLG, including any claim based upon negligence, breach of contract, breach of warranty, strict liability or any other theories upon which liability may be asserted against JLG.

This warranty constitutes JLG's entire and exclusive warranty as to the product and is the sole and exclusive remedy for product defects in material and workmanship. JLG does not assume (and has not authorized any other person to assume on its behalf) any other warranty or liability in connection with any product covered by this warranty. **JLG EXPRESSLY DISCLAIMS ANY AND ALL OTHER WARRANTIES OF ANY KIND WHATSOEVER AS TO THE PRODUCT FURNISHED HEREUNDER, INCLUDING BUT NOT LIMITED TO ANY EXPRESS WARRANTIES, EXCEPT FOR THE EXCLUSIVE WARRANTY PROVIDED HEREIN, OR IMPLIED WARRANTIES AS TO MERCHANTABILITY, OR FITNESS FOR ANY PARTICULAR PURPOSE.**

This warranty shall be void, if, upon the occurrence of any incident involving any product made by JLG and resulting in any personal injury or property damage, customer shall fail to notify JLG within 48 hours of such occurrence or permit JLG and its representatives to have immediate access to such product and all records of or within the control of customer relating to the product and occurrence.

The first part of the document discusses the importance of maintaining accurate records of all transactions. It emphasizes that every entry, no matter how small, should be recorded to ensure the integrity of the financial statements. This includes not only sales and purchases but also expenses and income.

The second part of the document provides a detailed breakdown of the accounting cycle. It outlines the ten steps involved in the process, from identifying the accounting entity to preparing financial statements. Each step is explained in detail, with examples provided to illustrate the concepts.

The third part of the document discusses the various types of accounts used in accounting. It categorizes accounts into assets, liabilities, equity, revenue, and expense accounts. It also explains the normal balances for each type of account and how they are used to calculate the net income or loss for a period.

The fourth part of the document discusses the importance of adjusting entries. It explains how these entries are used to ensure that the financial statements reflect the true financial position of the company at the end of the period. Examples of adjusting entries are provided to illustrate the process.

The fifth part of the document discusses the preparation of financial statements. It outlines the steps involved in preparing the balance sheet, income statement, and statement of owner's equity. It also discusses the importance of comparing the financial statements to the previous period to identify trends and changes.

The sixth part of the document discusses the importance of internal controls. It explains how these controls are used to prevent and detect errors and fraud. Examples of internal controls are provided to illustrate the concepts.

The seventh part of the document discusses the importance of ethics in accounting. It explains how accountants should maintain objectivity and integrity in their work. It also discusses the consequences of unethical behavior and the importance of following the code of ethics.

The eighth part of the document discusses the importance of communication in accounting. It explains how accountants should communicate effectively with their clients and colleagues. It also discusses the importance of providing clear and concise financial information.

The ninth part of the document discusses the importance of technology in accounting. It explains how accounting software can be used to streamline the accounting process and reduce the risk of errors. It also discusses the importance of staying up-to-date on the latest technology.

The tenth part of the document discusses the importance of continuing education in accounting. It explains how accountants should stay up-to-date on the latest accounting standards and regulations. It also discusses the importance of obtaining professional certifications.

6d

FCDN-2-2-166 (APPROVED 10/66) INDICATE METHOD BY NUMBER 03 OTHER CONTRACTUAL SERVICES 04 SUPPLIES & MATERIALS 05 EQUIPMENT XX MISCELLANEOUS	PURCHASE ORDER  PORT AUTHORITY OF GUAM 1026 CABRAS HIGHWAY SUITE 201 PITI, GUAM 96925	PURCHASE ORDER NO: 199010S This number must appear on all packages and papers pertaining to this order. Date: 2024-06-05
ID #98-0020236		

REQUISITION NUMBER: 00021658 ON	ALLOTMENT: C23F003.1782.1
--	----------------------------------

TO:	Federal Contracts Corp. 12918 N. Nebraska Ave. Tampa FL 33612	S H I P T O	Consignee, Destination and Marking PORT AUTHORITY OF GUAM 1026 CABRAS HIGHWAY SUITE 201 PITI, GUAM 96925
------------	--	--	---

Invitation No.	Contract No.	Time for Delivery	Expiring	Discount Terms
----------------	--------------	-------------------	----------	----------------

Delivery F.O.B.	Shipping Point	Ship Via	B.L. NO.
-----------------	----------------	----------	----------

Line	ARTICLES OR SERVICES	Qty	Unit	Unit Price	Amount
1.000	TELESCOPIC BOOM LIFT - Award of IFB-PAG-013-24 180 Telescopic Boom Lift Government of Guam Withholding Assessment Fee 4%: \$20,688.22 Point of Contact: JACQUE CRUZ, RAYMOND SANTOS (671)477-5931/5 EXTENSIONS 295 OR 294. Authority Code: 3109 Delivery: 180 days ARO Must comply to all Bid Specification, Requirements, and PAG Federal Contracts Supplement as attached. *****NOTHING FOLLOWS*****	1	EA	517205.4100	517205.41

1. THE GOVERNMENT OF GUAM WILL NOT BE RESPONSIBLE FOR ANY UNAUTHORIZED PURCHASES OR SERVICES.

2. DELIVER ALL MATERIALS TO PORT AUTHORITY OF GUAM SUPPLY WAREHOUSE 477-5931 X209/210.

3. TO BE COORDINATED WITH AGENCY AND VENDOR.

4. ALL LATE DELIVERIES AND ACCEPTANCES ARE SUBJECT TO THE LIQUIDATED DAMAGES CLAUSE IN SECTION 6101 (9)(a) OF THE GAR.

5. SUBJECT TO ALL REQUIRED TERMS AND CONDITIONS OF THE PAG FEDERAL CONTRACT SUPPLEMENT ATTACHED HERETO.

6. SUBJECT TO ALL REQUIRED TERMS AND CONDITIONS OF THE GUAM CONTRACT SUPPLEMENT ATTACHED HERETO.

NOTE: AMOUNTS DUE THIS PURCHASE ORDER MAY BE OFF SET FOR MONIES DUE THE GOVERNMENT OF GUAM INCLUSIVE OF BUT NOT LIMITED TO TAXES, FEES, AND RETURNED CHECKS PLUS FEES, INTERESTS OR OTHER DAMAGES, PENALTIES, AND ATTORNEY'S FEES AFTER FAILURE TO PAY ACCORDING TO LAW.

Certified Funds Available  Authorized Certifying Officer Jose B. Guevara III, Chief Financial Officer			TOTAL	517205.41
---	--	--	--------------	-----------

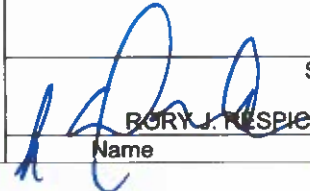
ORIGINAL Contractor please supply promptly the above article or services. All correspondence pertaining to this order including invoices, shipping documents and packages must bear the Purchase Order number shown above. See reverse side for billing and shipping instructions.	 Signature RORY J. RESPICIO, GENERAL MANAGER Name Title
--	---

FCDN-2-2-166 (APPROVED 10/66) INDICATE METHOD BY NUMBER 03 OTHER CONTRACTUAL SERVICES 04 SUPPLIES & MATERIALS 05 EQUIPMENT XX MISCELLANEOUS	PURCHASE ORDER  PORT AUTHORITY OF GUAM 1026 CABRAS HIGHWAY SUITE 201 PITI, GUAM 96925	PURCHASE ORDER NO: 199010S This number must appear on all packages and papers pertaining to this order. Date: 2024-06-05
ID #98-0020236		

REQUISITION NUMBER: 00021658 ON	ALLOTMENT: C23F003.1782.1
TO: Federal Contracts Corp. 12918 N. Nebraska Ave. Tampa FL 33612	S H I P T O Consignee, Destination and Marking PORT AUTHORITY OF GUAM 1026 CABRAS HIGHWAY SUITE 201 PITI, GUAM 96925

Invitation No.	Contract No.	Time for Delivery	Expiring	Discount Terms
Delivery F.O.B.	Shipping Point	Ship Via		B.L. NO.

Line	ARTICLES OR SERVICES	Qty	Unit	Unit Price	Amount
1.000	TELSCOPIC BOOM LIFT - Award of IFB-PAG-013-24 180 Telescopic Boom Lift Government of Guam Withholding Assessment Fee 4%: \$20,688.22 Point of Contact: JACQUE CRUZ, RAYMOND SANTOS (671)477-5931/5 EXTENSIONS 295 OR 294. Authority Code: 3109 Delivery: 180 days ARO Must comply to all Bid Specification, Requirements, and PAG Federal Contracts Supplement as attached. *****NOTHING FOLLOWS*****	1	EA	517205.4100	517205.41

1. THE GOVERNMENT OF GUAM WILL NOT BE RESPONSIBLE FOR ANY UNAUTHORIZED PURCHASES OR SERVICES.
 2. DELIVER ALL MATERIALS TO PORT AUTHORITY OF GUAM SUPPLY WAREHOUSE 477-5931 X209/210.
 3. TO BE COORDINATED WITH AGENCY AND VENDOR.
 4. ALL LATE DELIVERIES AND ACCEPTANCES ARE SUBJECT TO THE LIQUIDATED DAMAGES CLAUSE IN SECTION 6101 (9)(a) OF THE GAR.
 5. SUBJECT TO ALL REQUIRED TERMS AND CONDITIONS OF THE PAG FEDERAL CONTRACT SUPPLEMENT ATTACHED HERETO.
 6. SUBJECT TO ALL REQUIRED TERMS AND CONDITIONS OF THE GUAM CONTRACT SUPPLEMENT ATTACHED HERETO.

NOTE: AMOUNTS DUE THIS PURCHASE ORDER MAY BE OFF SET FOR MONIES DUE THE GOVERNMENT OF GUAM INCLUSIVE OF BUT NOT LIMITED TO TAXES, FEES, AND RETURNED CHECKS PLUS FEES, INTERESTS OR OTHER DAMAGES, PENALTIES, AND ATTORNEY'S FEES AFTER FAILURE TO PAY ACCORDING TO LAW.

Certified Funds Available  Authorized Certifying Officer Jose B. Guevara III, Chief Financial Officer				TOTAL	517205.41
---	--	--	--	--------------	-----------

ACKNOWLEDGEMENT COPY To: PAG MANAGEMENT DIVISION DATE OF RECEIPT OF ORDER: _____ VENDOR SIGNATURE _____	 Signature RORY JURISPICIO, GENERAL MANAGER Name Title
---	---

PORT AUTHORITY OF GUAM FEDERAL CONTRACT SUPPLEMENT

All boxes marked below are terms and conditions applicable to the Agreement entered by the Port Authority of Guam ("PAG") and Contractor, which is funded in whole or in part by federal award funds, as supplemented with these federally required terms. To the extent that any of the contractual terms, provisions, or conditions of the Agreement are inconsistent with the applicable terms, provisions, or conditions of this Federal Contract Supplement, the applicable terms of this Federal Contract Supplement shall govern.

DOMESTIC PRODUCTS PREFERENCE

As appropriate and to the extent consistent with law, there is a preference for the purchase, acquisition, or use of goods, products, or materials produced in the United States (including but not limited to iron, aluminum, steel, cement, and other manufactured products). The requirements of this section must be included in all subcontracts, including all purchase orders for work or products under this subaward. For purposes of this section: "Produced in the United States" means, for iron and steel products, that all manufacturing processes, from the initial melting stage through the application of coatings, occurred in the United States.

PROHIBITION ON CERTAIN TELECOMMUNICATIONS AND VIDEO SURVEILLANCE SERVICES AND EQUIPMENT

For the purpose of public safety, security of government facilities, physical security surveillance of critical infrastructure, and other national security purposes, Contractor and all subcontractors are prohibited from procuring, obtaining, or purchasing: 1) equipment, services, or systems that uses covered telecommunications equipment or services as a substantial or essential component of any system, or as critical technology as part of any system. As described in Public Law 115-232, section 889, covered telecommunications equipment is telecommunications equipment produced by Huawei Technologies Company or ZTE Corporation (or any subsidiary or affiliate of such entities); 2) video surveillance and telecommunications equipment produced by Hytera Communications Corporation, Hangzhou Hikvision Digital Technology Company, or Dahua Technology Company (or any subsidiary or affiliate of such entities); 3) telecommunications or video surveillance services provided by such entities or using such equipment; and 4) telecommunications or video surveillance equipment or services produced or provided by an entity that the Secretary of Defense, in consultation with the Director of the National Intelligence or the Director of the Federal Bureau of Investigation, reasonably believes to be an entity owned or controlled by, or otherwise connected to, the government of a covered foreign country.

PROCUREMENT OF RECOVERED MATERIALS

Contractor and all subcontractors must comply with section 6002 of the Solid Waste Disposal Act, as amended by the Resource Conservation and Recovery Act. The requirements of Section 6002 include procuring only items designated in guidelines of the Environmental Protection Agency (EPA) at 40 CFR part 247 that contain the highest percentage of recovered materials practicable,

consistent with maintaining a satisfactory level of competition, where the purchase price of the item exceeds \$10,000 or the value of the quantity acquired during the preceding fiscal year exceeded \$10,000; procuring solid waste management services in a manner that maximizes energy and resource recovery; and establishing an affirmative procurement program for procurement of recovered materials identified in the EPA guidelines.

UNALLOWABLE COSTS

Contractor agrees to comply with all applicable laws, regulations, policies, and guidance (including specific cost limits, prior approval and reporting requirements, where applicable) governing the use of federal funds. Costs that are expressly unallowable under federal funding laws, or costs which specifically become designated as unallowable as a result of a written decision furnished by a contracting officer pursuant to contract dispute procedures, or costs which are mutually agreed to be unallowable, including mutually agreed to be unallowable directly associated costs, shall be identified and excluded from any invoice, billing, claim, or proposal applicable to a federally funded contract. A directly associated cost is any cost which is generated solely as a result of incurring another cost, and which would not have been incurred had the other cost not been incurred. When an unallowable cost is incurred, its directly associated costs are also unallowable. Contractor agrees to pay any penalties associated with any unallowable costs.

NO OBLIGATION BY THE FEDERAL GOVERNMENT

PAG and Contractor acknowledge and agree that, notwithstanding any concurrence by the Federal Government in or approval of the solicitation or award of the underlying Agreement, absent the express written consent by the Federal Government, the Federal Government is not a party to this contract and shall not be subject to any obligations or liabilities to PAG. Contractor, or any other party (whether or not a party to the contract) pertaining to any matter resulting from the underlying contract. Contractor agrees to include the above clause in each subcontract financed in whole or in part with Federal funds under this Agreement. It is further agreed that the clause shall not be modified, except to identify the subcontractor who will be subject to its provisions.

FEDERAL LOBBYING

The Contractor certifies, to the best of his or her knowledge and belief, that:

A. No Federal appropriated funds have been paid or will be paid, by or on behalf of the undersigned, to any person for influencing or attempting to influence an officer or employee of an agency, a Member of Congress, an officer or employee of Congress, or an employee of a Member of Congress in connection with the awarding of this Agreement, the making of any Federal grant, the making of any Federal loan, the entering into of any cooperative agreement, and the extension, continuation, renewal, amendment, or modification of this Agreement or any Federal grant, loan, or cooperative agreement.

B. If any funds other than Federal appropriated funds have been paid or will be paid to any person for making lobbying contacts to an officer or employee of any agency, a Member of Congress, an officer or employee of Congress, or an employee of a Member of Congress in connection with this Agreement, or any Federal grant, loan, or cooperative agreement, the undersigned shall complete and submit Standard Form--LLL, "Disclosure Form to Report Lobbying," in accordance with its instructions [as amended by "Government wide Guidance for New Restrictions on Lobbying," 61 Fed. Reg. 1413 (1/19/96). Note: Language in paragraph (2) herein has been modified in accordance with Section 10 of the Lobbying Disclosure Act of 1995 (P.L. 104-65, to be codified at 2 U.S.C. 1601, et seq.)]

C. The Contractor shall require that the language of this certification be included in the award documents for all subawards at all tiers (including subcontracts, subgrants, and contracts under grants, loans, and cooperative agreements) and that all subcontractors shall certify and disclose accordingly.

D. This certification is a material representation of fact upon which reliance was placed when this transaction was made or entered into. Submission of this certification is a prerequisite for making or entering into this Agreement. The Contractor certifies or affirms the truthfulness and accuracy of each statement of this certification and disclosure. In addition, the Contractor understands and agrees that the provisions of 31 U.S.C. A 3801, et seq., apply to this certification and disclosure.

ALL PUBLISHED ITEMS AND DELIVERABLES MUST INCLUDE NAME OF FEDERAL AWARDING AGENCY AND AWARD NUMBER

Contractor agrees to include the Program logo and the logos of the Federal Awarding Agency, the PAG, and the government of Guam on any materials developed for publication. Contractor further agrees to ensure statements, press releases, public service announcements, media interviews, requests for proposals, bid solicitations, and other documents or activities carried out in whole or part with program funds shall clearly state: (1) the dollar amount of federal funds for the project; (2) the Federal Award Number; and (3) the involvement of the Federal Awarding Agency, the PAG, and the government of Guam.

DEBARMENT (GUAM AND FEDERAL)

A. Guam Debarment and Suspension. Contractor warrants that it will comply with the provisions of 5 GCA Chapter 5 Articles 9 and 11, subject to debarment or suspension, and that it will not employ any subcontractors who have been federally debarred or debarred by the Government of Guam.

B. Federal Debarment and Suspension (Executive Orders 12549 and 12689). A contract award (see 2 CFR 180.220) must not be made to parties listed on the government-wide exclusions in the System for Award Management (SAM), in accordance with the OMB guidelines at 2 CFR 180 that implement Executive Orders 12549 (3 CFR part 1986 Comp., p. 189) and 12689 (3 CFR

part 1989 Comp., p. 235), "Debarment and Suspension." SAM Exclusions contains the names of parties debarred, suspended, or otherwise excluded by agencies, as well as parties declared ineligible under statutory or regulatory authority other than Executive Order 12549. As required by Executive Order 12549, Debarment and Suspension, and implemented at 34 CFR Part 85, for prospective participants in primary covered transactions, as defined at 34 CFR Part 85, Sections 85.105 and 85.110. The Contractor certifies that it and its principals: 1) Are not presently debarred, suspended, proposed for debarment, declared ineligible, or voluntarily excluded from covered transactions by any federal department or agency; 2) Have not within a three-year period preceding this application been convicted of or had a civil judgment rendered against them for commission of fraud or a criminal offense in connection with obtaining, attempting to obtain, or performing a public (federal, state, or local) transaction or contract under a public transaction; violation of federal or state antitrust statutes or commission of embezzlement, theft, forgery, bribery, falsification or destruction of records, making false statements, or receiving stolen property; 3) Are not presently indicted for or otherwise criminally or civilly charged by a governmental entity (federal, state, or local) with commission of any of the offenses enumerated above; and 4) Have not within a three-year period preceding this application had one or more public transactions (federal, state, or local) terminated for cause or default. Contractor further warrants that it is not a party listed on the government wide exclusions in the System for Award Management (SAM), and will comply with the provisions of Subpart C of 2 CFR Part 1326, "Nonprocurement Debarment and Suspension," (published in the Federal Register on December 21, 2006, 71 FR 76573) which generally prohibits entities that have been debarred, suspended, or voluntarily excluded from participating in nonprocurement transactions either through primary or lower tier covered transactions, and which sets forth the responsibilities of recipients of federal financial assistance regarding transactions with other persons, including subrecipients and contractors. Contractor will provide a Certification Regarding Debarment, Suspension, Ineligibility, and Voluntary Exclusion, Lower Tier Covered Transaction (Sub-Recipient), which is a material representation of fact. Submission of this certification is a pre-requisite for entering into this Agreement, imposed by Executive Order 12549, 28 CFR Part 67, Section 67.510.

ACCESS TO RECORDS, INSPECTION, AND AUDIT REVIEW

A. **Access to Records.** The Contractor, including its subcontractors, if any, shall maintain all books, documents, papers, accounting records and other evidence pertaining to costs incurred and to make such materials available at their respective office at all reasonable times during the contract period and for three (3) years from the date of final payment under this Formal Agreement, for inspection by the PAG. Each subcontract by the Contractor pursuant to this Agreement shall include a provision containing the conditions of this Section.

B. **Right to Audit.** Contractor shall establish and maintain a reasonable accounting system that enables the PAG to readily identify Contractor's assets, expenses, costs of goods, and use of funds. the PAG and its authorized representatives shall have the right to audit, to examine, and to make copies of or extracts from all financial and related records (in whatever form they may be kept, whether written, electronic, or other) relating to or pertaining to this Agreement kept by or under the control of the Contractor, including, but not limited to those kept by the Contractor, its employees, agents, assigns, successors, and subcontractors. Such records shall include, but not be

limited to, accounting records, written policies and procedures; subcontract files (including proposals of successful and unsuccessful bidders, bid recaps, etc.); all paid vouchers including those for out-of-pocket expenses; other reimbursement supported by invoices; ledgers; cancelled checks; deposit slips; bank statements; journals; original estimates; estimating work sheets; contract amendments and change order files; backcharge logs and supporting documentation; insurance documents; payroll documents; timesheets; memoranda; and correspondence. Contractor shall, at all times during the term of this Agreement and for a period of ten years after the completion of this Agreement, maintain such records, together with such supporting or underlying documents and materials. The Contractor shall at any time requested by the PAG, whether during or after completion of this Agreement, and at Contractor's own expense make such records available for inspection and audit (including copies and extracts of records as required) by the PAG. Such records shall be made available to the PAG during normal business hours at the Contractor's office or place of business and [subject to a three-day written notice/without prior notice]. In the event that no such location is available, then the financial records, together with the supporting or underlying documents and records, shall be made available for audit at a time and location that is convenient for the PAG. Contractor shall ensure the PAG has these rights with Contractor's employees, agents, assigns, successors, and subcontractors, and the obligations of these rights shall be explicitly included in any subcontracts or agreements formed between the Contractor and any subcontractors to the extent that those subcontracts or agreements relate to fulfillment of the Contractor's obligations to the PAG. Costs of any audits conducted under the authority of this right to audit and not addressed elsewhere will be borne by the PAG unless certain exemption criteria are met. If the audit identifies overpricing or overcharges (of any nature) by the Contractor to the PAG in excess of one-half of one percent (.5%) of the total contract billings, the Contractor shall reimburse the PAG for the total costs of the audit. If the audit discovers substantive findings related to fraud, misrepresentation, or non-performance, the PAG may recoup the costs of the audit work from the Contractor. Any adjustments and/or payments that must be made as a result of any such audit or inspection of the Contractor's invoices and/or records shall be made within a reasonable amount of time (not to exceed 90 days) from presentation of the PAG's findings to Contractor.

C. **Right to Enter and Inspect.** the PAG may, at any time, without notice, enter and inspect a Contractor's or subcontractor's facilities, place(s) of business, or any place(s) of performance of this Agreement. the PAG may enter and inspect any plans, supplies, services, equipment, work and records at these locations which are related to the performance of this Agreement, and may conduct any testing deemed necessary to determine whether the Contractor's or subcontractor's compliance or conformity to the solicitation or contract requirements. Guam may enter and audit the cost or pricing data, books, and records of the Contractor or any subcontractor, and/or investigate in connection with an action to debar or suspend a person from consideration for award of contracts pursuant to §9102 (Authority to Debar or Suspend) of the Guam Procurement Rules and Regulations.

FEDERAL REQUIREMENTS

Contractor agrees to comply with all applicable federal law, regulations, and executive orders, all standards, orders, requirements set forth under the federal award that is funding this Agreement, and all policies, procedures, and directives issued by the Federal Awarding Agency.

MODIFICATION

This Agreement may only be amended, modified, or extended in accordance with the applicable federal law, the terms and conditions of the federal award that is funding this Agreement, and the policies and procedures of the Federal Awarding Agency. Deviations from budget, project scope, objective, and/or time of performance require notification to the Federal Awarding Agency, and may require prior approval of the Federal Awarding Agency.

FALSE CLAIMS AND WHISTLEBLOWERS

Contractor acknowledges that 31 U.S.C. Chap. 38 (Administrative Remedies for False Claims and Statements) and Title 5 GCA Chapter 37, the False Claims and Whistleblower Act applies to this Agreement and to all Contractor's actions pertaining to this Agreement. The False Claims and Whistleblower Act was passed as Public Law 34-116, Chapter III, Section 20 (lapsed into law August 24, 2018) and codified at Title 5 GCA Chapter 37.

IMPLEMENTATION OF CLEAN AIR ACT AND FEDERAL WATER POLLUTION CONTROL ACT

(APPLICABLE TO ALL CONTRACTS AND SUBCONTRACTS EXCEEDING \$150,000)

Contractor agrees to comply with all applicable standards, orders, or requirements issued under Section 306 of the Clean Air Act (42 USC, 1857H), Section 508 of the Clean Water Act (33 USC, 1368), Executive Order 11378, and Environmental Protection Agency regulations (40 C.F.R., Part 15), which prohibit the use under nonexempt federal contracts, grants, or loans of facilities included on the EPA list of Violating Facilities. Contractor shall report violations to the PAG and to the USEPA Assistant Administrator for Enforcement (ENO329).

By executing this contract, and any subcontracts, as appropriate, the Contractor and any subcontractors will be deemed to have stipulated as follows:

A. That any person who is or will be utilized in the performance of this contract is not prohibited from receiving an award due to a violation of Section 508 of the Clean Water Act or Section 306 of the Clean Air Act.

B. That the Contractor agrees to include or cause to be included the requirements of paragraph (A) of this Section in every subcontract, and further agrees to take such action as the contracting agency may direct as a means of enforcing such requirements.

□ EQUAL EMPLOYMENT OPPORTUNITY COMPLIANCE
(APPLICABLE TO ALL CONSTRUCTION CONTRACTS AND SUBCONTRACTS)

The Contractor and all subcontractors must comply with the following policies: Executive Order 11246, 41 CFR 60, 29 CFR 1625-1627, Title 23 USC Section 140, the Rehabilitation Act of 1973, as amended (29 USC 794), Title VI of the Civil Rights Act of 1964, as amended, and related regulations including 49 CFR Parts 21, 26 and 27; and 23 CFR Parts 200, 230, and 633.

The Contractor and all subcontractors must also comply with: the requirements of the Equal Opportunity Clause in 41 CFR 60-1.4(b) and, for all construction contracts exceeding \$10,000, the Standard Federal Equal Employment Opportunity Construction Contract Specifications in 41 CFR 60-4.3.

A. Equal Employment Opportunity: Equal employment opportunity (EEO) requirements not to discriminate and to take affirmative action to assure equal opportunity as set forth under laws, executive orders, rules, regulations (28 CFR 35, 29 CFR 1630, 29 CFR 1625-1627, 41 CFR 60 and 49 CFR 27) and orders of the Secretary of Labor as modified by the provisions prescribed herein, and imposed pursuant to 23 U.S.C. 140 shall constitute the EEO and specific affirmative action standards for the Contractor's project activities under this contract. The provisions of the Americans with Disabilities Act of 1990 (42 U.S.C. 12101 et seq.) set forth under 28 CFR 35 and 29 CFR 1630 are incorporated by reference in this contract. In the execution of this contract, the Contractor agrees to comply with the following minimum specific requirement activities of EEO:

1) The Contractor will work with the PAG and the Federal Government to ensure that it has made every good faith effort to provide equal opportunity with respect to all of its terms and conditions of employment and in their review of activities under the contract.

2) The Contractor will accept as its operating policy the following statement:

"It is the policy of this Company to assure that applicants are employed, and that employees are treated during employment, without regard to their race, religion, sex, color, national origin, age or disability. Such action shall include: employment, upgrading, demotion, or transfer; recruitment or recruitment advertising; layoff or termination; rates of pay or other forms of compensation; and selection for training, including apprenticeship, pre-apprenticeship, and/or on-the-job training."

B. EEO Officer: The Contractor will designate and make known to the contracting officers an EEO Officer who will have the responsibility for and must be capable of effectively administering and promoting an active EEO program and who must be assigned adequate authority and responsibility to do so.

C. Dissemination of Policy: All members of the Contractor's staff who are authorized to hire, supervise, promote, and discharge employees, or who recommend such action, or who are substantially involved in such action, will be made fully cognizant of, and will implement, the Contractor's EEO policy and contractual responsibilities to provide EEO in each grade and classification of employment. To ensure that the above agreement will be met, the following actions will be taken as a minimum:

1) Periodic meetings of supervisory and personnel office employees will be conducted before the start of work and then not less often than once every six months, at which time the Contractor's EEO policy and its implementation will be reviewed and explained. The meetings will be conducted by the EEO Officer.

2) All new supervisory or personnel office employees will be given a thorough indoctrination by the EEO Officer, covering all major aspects of the Contractor's EEO obligations within thirty days following their reporting for duty with the Contractor.

3) All personnel who are engaged in direct recruitment for the project will be instructed by the EEO Officer in the Contractor's procedures for locating and hiring minorities and women.

4) Notices and posters setting forth the Contractor's EEO policy will be placed in areas readily accessible to employees, applicants for employment and potential employees.

5) The Contractor's EEO policy and the procedures to implement such policy will be brought to the attention of employees by means of meetings, employee handbooks, or other appropriate means.

D. Recruitment: When advertising for employees, the Contractor will include in all advertisements for employees the notation: "An Equal Opportunity Employer." All such advertisements will be placed in publications having a large circulation among minorities and women in the area from which the project work force would normally be derived.

1) The Contractor will, unless precluded by a valid bargaining agreement, conduct systematic and direct recruitment through public and private employee referral sources likely to yield qualified minorities and women. To meet this requirement, the Contractor will identify sources of potential minority group employees, and establish with such identified sources procedures whereby minority and women applicants may be referred to the Contractor for employment consideration.

2) In the event the Contractor has a valid bargaining agreement providing for exclusive hiring hall referrals, the Contractor is expected to observe the provisions of that agreement to the extent that the system meets the Contractor's compliance with EEO contract provisions. Where implementation of such an agreement has the effect of discriminating against minorities or women, or obligates the Contractor to do the same, such implementation violates Federal nondiscrimination provisions.

3) The Contractor will encourage its present employees to refer minorities and women as applicants for employment. Information and procedures with regard to referring such applicants will be discussed with employees.

E. Personnel Actions: Wages, working conditions, and employee benefits shall be established and administered, and personnel actions of every type, including hiring, upgrading, promotion, transfer, demotion, layoff, and termination, shall be taken without regard to race, color, religion, sex, national origin, age or disability. The following procedures shall be followed:

1) The Contractor will conduct periodic inspections of project sites to insure that working conditions and employee facilities do not indicate discriminatory treatment of project site personnel.

2) The Contractor will periodically evaluate the spread of wages paid within each classification to determine any evidence of discriminatory wage practices.

3) The Contractor will periodically review selected personnel actions in depth to determine whether there is evidence of discrimination. Where evidence is found, the Contractor will promptly take corrective action. If the review indicates that the discrimination may extend beyond the actions reviewed, such corrective action shall include all affected persons.

4) The Contractor will promptly investigate all complaints of alleged discrimination made to the Contractor in connection with its obligations under this Agreement, will attempt to resolve such complaints, and will take appropriate corrective action within a reasonable time. If the investigation indicates that the discrimination may affect persons other than the complainant, such corrective action shall include such other persons. Upon completion of each investigation, the Contractor will inform every complainant of all of their avenues of appeal.

F. Training and Promotion:

1) The Contractor will assist in locating, qualifying, and increasing the skills of minorities and women who are applicants for employment or current employees. Such efforts should be aimed at developing full journey level status employees in the type of trade or job classification involved.

2) Consistent with the Contractor's work force requirements and as permissible under Federal and State regulations, the Contractor shall make full use of training programs, i.e., apprenticeship, and on-the-job training programs for the geographical area of contract performance. In the event a special provision for training is provided under this Agreement, this subparagraph will be superseded as indicated in the special provision. the PAG may reserve training positions for persons who receive welfare assistance in accordance with 23 U.S.C. 140(a).

3) The Contractor will advise employees and applicants for employment of available training programs and entrance requirements for each.

4) The Contractor will periodically review the training and promotion potential of employees who are minorities and women and will encourage eligible employees to apply for such training and promotion.

G. Unions: If the Contractor relies in whole or in part upon unions as a source of employees, the Contractor will use good faith efforts to obtain the cooperation of such unions to increase opportunities for minorities and women. Actions by the Contractor, either directly or through a contractor's association acting as agent, will include the procedures set forth below:

1) The Contractor will use good faith efforts to develop, in cooperation with the unions, joint training programs aimed toward qualifying more minorities and women for membership in the unions and increasing the skills of minorities and women so that they may qualify for higher paying employment.

2) The Contractor will use good faith efforts to incorporate an EEO clause into each union agreement to the end that such union will be contractually bound to refer applicants without regard to their race, color, religion, sex, national origin, age or disability.

3) The Contractor is to obtain information as to the referral practices and policies of the labor union except that to the extent such information is within the exclusive possession of the labor union and such labor union refuses to furnish such information to the Contractor, the

Contractor shall so certify to the PAG and shall set forth what efforts have been made to obtain such information.

4) In the event the union is unable to provide the Contractor with a reasonable flow of referrals within the time limit set forth in the collective bargaining agreement, the Contractor will, through independent recruitment efforts, fill the employment vacancies without regard to race, color, religion, sex, national origin, age or disability; making full efforts to obtain qualified and/or qualifiable minorities and women. The failure of a union to provide sufficient referrals (even though it is obligated to provide exclusive referrals under the terms of a collective bargaining agreement) does not relieve the Contractor from the requirements of this paragraph. In the event the union referral practice prevents the Contractor from meeting the obligations pursuant to Executive Order 11246, as amended, and these special provisions, the Contractor shall immediately notify the PAG.

H. Reasonable Accommodation for Applicants/Employees with Disabilities: The Contractor must be familiar with the requirements for and comply with the Americans with Disabilities Act and all rules and regulations established thereunder. Employers must provide reasonable accommodation in all employment activities unless to do so would cause an undue hardship.

I. Selection of Subcontractors, Procurement of Materials and Leasing of Equipment: The Contractor shall not discriminate on the grounds of race, color, religion, sex, national origin, age or disability in the selection and retention of subcontractors, including procurement of materials and leases of equipment. The Contractor shall take all necessary and reasonable steps to ensure nondiscrimination in the administration of this Agreement.

1) The Contractor shall notify all potential subcontractors and suppliers and lessors of their EEO obligations under this Agreement.

2) The Contractor will use good faith efforts to ensure subcontractor compliance with their EEO obligations.

J. Records and Reports: The Contractor shall keep such records as necessary to document compliance with the EEO requirements. Such records shall be retained for a period of three years following the date of the final payment to the Contractor for all the Work under this Agreement and shall be available at reasonable times and places for inspection by authorized representatives of the PAG.

1) The records kept by the Contractor shall document the following:

(a) The number and work hours of minority and non-minority group members and women employed in each work classification on the project;

(b) The progress and efforts being made in cooperation with unions, when applicable, to increase employment opportunities for minorities and women; and

(c) The progress and efforts being made in locating, hiring, training, qualifying, and upgrading minorities and women;

2) The Contractor and any subcontractors will submit an annual report to the PAG each July for the duration of the Project, indicating the number of minority, women, and non-minority

group employees currently engaged in each work classification required by the Work under this Agreement. The staffing data should represent the project work force on board in all or any part of the last payroll period preceding the end of July. If on-the-job training is being required by special provision, the Contractor will be required to collect and report training data. The employment data should reflect the work force on board during all or any part of the last payroll period preceding the end of July.

NONSEGREGATED FACILITIES

(APPLICABLE TO ALL CONSTRUCTION CONTRACTS AND SUBCONTRACTS)

The Contractor must ensure that facilities provided for employees are provided in such a manner that segregation on the basis of race, color, religion, sex, or national origin cannot result. The Contractor may neither require such segregated use by written or oral policies nor tolerate such use by employee custom. The Contractor's obligation extends further to ensure that its employees are not assigned to perform their services at any location, under the Contractor's control, where the facilities are segregated. The term "facilities" includes waiting rooms, work areas, restaurants and other eating areas, time clocks, restrooms, washrooms, locker rooms, and other storage or dressing areas, parking lots, drinking fountains, recreation or entertainment areas, transportation, and housing provided for employees. The Contractor shall provide separate or single-user restrooms and necessary dressing or sleeping areas to assure privacy between sexes.

DAVIS-BACON ACT COMPLIANCE

(APPLICABLE TO ALL CONSTRUCTION CONTRACTS AND SUBCONTRACTS
EXCEEDING \$2,000)

A. Minimum wages

1) All laborers and mechanics employed or working upon the site of the work, will be paid unconditionally and not less often than once a week, and without subsequent deduction or rebate on any account (except such payroll deductions as are permitted by regulations issued by the Secretary of Labor under the Copeland Act (29 CFR part 3)), the full amount of wages and bona fide fringe benefits (or cash equivalents thereof) due at time of payment computed at rates not less than those contained in the wage determination of the Secretary of Labor which is attached hereto and made a part hereof, regardless of any contractual relationship which may be alleged to exist between the Contractor and such laborers and mechanics.

Contributions made or costs reasonably anticipated for bona fide fringe benefits under section 1(b)(2) of the Davis-Bacon Act on behalf of laborers or mechanics are considered wages paid to such laborers or mechanics, subject to the provisions of paragraph 1.d. of this section; also, regular contributions made or costs incurred for more than a weekly period (but not less often than quarterly) under plans, funds, or programs which cover the particular weekly period, are deemed to be constructively made or incurred during such weekly period. Such laborers and mechanics shall be paid the appropriate wage rate and fringe benefits on the wage determination for the classification of work actually performed, without regard to skill, except as provided in

29 CFR 5.5(a)(4). Laborers or mechanics performing work in more than one classification may be compensated at the rate specified for each classification for the time actually worked therein: Provided, That the employer's payroll records accurately set forth the time spent in each classification in which work is performed. The wage determination (including any additional classification and wage rates conformed under paragraph 1.b. of this section) and the Davis-Bacon poster (WH-1321) shall be posted at all times by the Contractor and its subcontractors at the site of the work in a prominent and accessible place where it can be easily seen by the workers.

2) The contracting officer shall require that any class of laborers or mechanics, including helpers, which is not listed in the wage determination and which is to be employed under the contract shall be classified in conformance with the wage determination. The contracting officer shall approve an additional classification and wage rate and fringe benefits therefore only when the following criteria have been met:

- (i) The work to be performed by the classification requested is not performed by a classification in the wage determination; and
- (ii) The classification is utilized in the area by the construction industry; and
- (iii) The proposed wage rate, including any bona fide fringe benefits, bears a reasonable relationship to the wage rates contained in the wage determination.

3) If the Contractor and the laborers and mechanics to be employed in the classification (if known), or their representatives, and the contracting officer agree on the classification and wage rate (including the amount designated for fringe benefits where appropriate), a report of the action taken shall be sent by the contracting officer to the Administrator of the Wage and Hour Division, Employment Standards Administration, U.S. Department of Labor, Washington, DC 20210. The Administrator, or an authorized representative, will approve, modify, or disapprove every additional classification action within 30 days of receipt and so advise the contracting officer or will notify the contracting officer within the 30-day period that additional time is necessary.

4) In the event the Contractor, the laborers or mechanics to be employed in the classification or their representatives, and the contracting officer do not agree on the proposed classification and wage rate (including the amount designated for fringe benefits, where appropriate), the contracting officer shall refer the questions, including the views of all interested parties and the recommendation of the contracting officer, to the Wage and Hour Administrator for determination. The Wage and Hour Administrator, or an authorized representative, will issue a determination within 30 days of receipt and so advise the contracting officer or will notify the contracting officer within the 30-day period that additional time is necessary.

5) The wage rate (including fringe benefits where appropriate) determined pursuant to paragraphs 1.b.(2) or 1.b.(3) of this section, shall be paid to all workers performing work in the classification under this contract from the first day on which work is performed in the classification.

6) Whenever the minimum wage rate prescribed in the contract for a class of laborers or mechanics includes a fringe benefit which is not expressed as an hourly rate, the Contractor shall either pay the benefit as stated in the wage determination or shall pay another bona fide fringe benefit or an hourly cash equivalent thereof.

7) If the Contractor does not make payments to a trustee or other third person, the Contractor may consider as part of the wages of any laborer or mechanic the amount of any costs reasonably anticipated in providing bona fide fringe benefits under a plan or program, Provided, That the Secretary of Labor has found, upon the written request of the Contractor, that the applicable standards of the Davis-Bacon Act have been met. The Secretary of Labor may require the Contractor to set aside, in a separate account, assets for the meeting of obligations under the plan or program.

B. Withholding

The contracting agency shall upon its own action or upon written request of an authorized representative of the Department of Labor, withhold or cause to be withheld from the Contractor under this contract, or any other Federal contract with the same prime Contractor, or any other federally-assisted contract subject to Davis-Bacon prevailing wage requirements, which is held by the same prime Contractor, so much of the accrued payments or advances as may be considered necessary to pay laborers and mechanics, including apprentices, trainees, and helpers, employed by the Contractor or any subcontractor the full amount of wages required by the contract. In the event of failure to pay any laborer or mechanic, including any apprentice, trainee, or helper, employed or working on the site of the work, all or part of the wages required by the contract, the PAG may, after written notice to the Contractor, take such action as may be necessary to cause the suspension of any further payment, advance, or guarantee of funds until such violations have ceased.

C. Payrolls and Basic Records

1) Payrolls and basic records relating thereto shall be maintained by the Contractor during the course of the work and preserved for a period of three years thereafter for all laborers and mechanics working at the site of the work. Such records shall contain the name, address, and social security number of each such worker, his or her correct classification, hourly rates of wages paid (including rates of contributions or costs anticipated for bona fide fringe benefits or cash equivalents thereof of the types described in section 1(b)(2)(B) of the Davis-Bacon Act), daily and weekly number of hours worked, deductions made and actual wages paid. Whenever the Secretary of Labor has found under 29 CFR 5.5(a)(1)(iv) that the wages of any laborer or mechanic include the amount of any costs reasonably anticipated in providing benefits under a plan or program described in section 1(b)(2)(B) of the Davis-Bacon Act, the Contractor shall maintain records which show that the commitment to provide such benefits is enforceable, that the plan or program is financially responsible, and that the plan or program has been communicated in writing to the laborers or mechanics affected, and records which show the costs anticipated or the actual cost incurred in providing such benefits. Contractors employing apprentices or trainees under approved programs shall maintain written evidence of the

registration of apprenticeship programs and certification of trainee programs, the registration of the apprentices and trainees, and the ratios and wage rates prescribed in the applicable programs.

2) The Contractor shall submit weekly for each week in which any contract work is performed a copy of all payrolls to the PAG. The payrolls submitted shall set out accurately and completely all of the information required to be maintained under 29 CFR 5.5(a)(3)(i), except that full social security numbers and home addresses shall not be included on weekly transmittals. Instead the payrolls shall only need to include an individually identifying number for each employee (e.g., the last four digits of the employee's social security number). The required weekly payroll information may be submitted in any form desired. Optional Form WH-347 is available for this purpose from the Wage and Hour Division Web site at <http://www.dol.gov/esa/whd/forms/wh347instr.htm> or its successor site. The prime Contractor is responsible for the submission of copies of payrolls by all subcontractors. Contractors and subcontractors shall maintain the full social security number and current address of each covered worker, and shall provide them upon request to the PAG for transmission to the Wage and Hour Division of the Department of Labor for purposes of an investigation or audit of compliance with prevailing wage requirements. It is not a violation of this section for a prime contractor to require a subcontractor to provide addresses and social security numbers to the prime contractor for its own records, without weekly submission to the PAG.

3) Each payroll submitted shall be accompanied by a "Statement of Compliance," signed by the Contractor or subcontractor or his or her agent who pays or supervises the payment of the persons employed under the contract and shall certify the following:

(i) That the payroll for the payroll period contains the information required to be provided under §5.5 (a)(3)(ii) of Regulations, 29 CFR part 5, the appropriate information is being maintained under §5.5 (a)(3)(i) of Regulations, 29 CFR part 5, and that such information is correct and complete;

(ii) That each laborer or mechanic (including each helper, apprentice, and trainee) employed on the contract during the payroll period has been paid the full weekly wages earned, without rebate, either directly or indirectly, and that no deductions have been made either directly or indirectly from the full wages earned, other than permissible deductions as set forth in Regulations, 29 CFR part 3;

(iii) That each laborer or mechanic has been paid not less than the applicable wage rates and fringe benefits or cash equivalents for the classification of work performed, as specified in the applicable wage determination incorporated into the contract.

4) The weekly submission of a properly executed certification set forth on the reverse side of Optional Form WH-347 shall satisfy the requirement for submission of the "Statement of Compliance" required by paragraph 3.b.(2) of this section.

5) The falsification of any of the above certifications may subject the Contractor or subcontractor to civil or criminal prosecution under section 1001 of title 18 and section 231 of title 31 of the United States Code.

6) The Contractor or subcontractor shall make the records required under this section available for inspection, copying, or transcription by authorized representatives of the contracting agency or the Department of Labor, and shall permit such representatives to interview employees during working hours on the job. If the Contractor or subcontractor fails to submit the required records or to make them available, the Federal granting agency may, after written notice to the Contractor, or the contracting agency, take such action as may be necessary to cause the suspension of any further payment, advance, or guarantee of funds. Furthermore, failure to submit the required records upon request or to make such records available may be grounds for debarment action pursuant to 29 CFR 5.12.

D. Apprentices and trainees

1) Apprentices (programs of the USDOL).

Apprentices will be permitted to work at less than the predetermined rate for the work they performed when they are employed pursuant to and individually registered in a bona fide apprenticeship program registered with the U.S. Department of Labor, Employment and Training Administration, Office of Apprenticeship Training, Employer and Labor Services, or with a State Apprenticeship Agency recognized by the Office, or if a person is employed in his or her first 90 days of probationary employment as an apprentice in such an apprenticeship program, who is not individually registered in the program, but who has been certified by the Office of Apprenticeship Training, Employer and Labor Services or a State Apprenticeship Agency (where appropriate) to be eligible for probationary employment as an apprentice.

The allowable ratio of apprentices to journeymen on the job site in any craft classification shall not be greater than the ratio permitted to the Contractor as to the entire work force under the registered program. Any worker listed on a payroll at an apprentice wage rate, who is not registered or otherwise employed as stated above, shall be paid not less than the applicable wage rate on the wage determination for the classification of work actually performed. In addition, any apprentice performing work on the job site in excess of the ratio permitted under the registered program shall be paid not less than the applicable wage rate on the wage determination for the work actually performed. Where a contractor is performing construction on a project in a locality other than that in which its program is registered, the ratios and wage rates (expressed in percentages of the journeyman's hourly rate) specified in the Contractor's or subcontractor's registered program shall be observed.

Every apprentice must be paid at not less than the rate specified in the registered program for the apprentice's level of progress, expressed as a percentage of the journeymen hourly rate specified in the applicable wage determination. Apprentices shall be paid fringe benefits in accordance with the provisions of the apprenticeship program. If the apprenticeship program does not specify fringe benefits, apprentices must be paid the full amount of fringe benefits listed on the wage determination for the applicable classification. If the Administrator determines that a different practice prevails for the applicable apprentice classification, fringes shall be paid in accordance with that determination.

In the event the Office of Apprenticeship Training, Employer and Labor Services, or a State Apprenticeship Agency recognized by the Office, withdraws approval of an apprenticeship program, the Contractor will no longer be permitted to utilize apprentices at less than the applicable predetermined rate for the work performed until an acceptable program is approved.

2) Trainees (programs of the USDOL).

Except as provided in 29 CFR 5.16, trainees will not be permitted to work at less than the predetermined rate for the work performed unless they are employed pursuant to and individually registered in a program which has received prior approval, evidenced by formal certification by the U.S. Department of Labor, Employment and Training Administration.

The ratio of trainees to journeymen on the job site shall not be greater than permitted under the plan approved by the Employment and Training Administration.

Every trainee must be paid at not less than the rate specified in the approved program for the trainee's level of progress, expressed as a percentage of the journeyman hourly rate specified in the applicable wage determination. Trainees shall be paid fringe benefits in accordance with the provisions of the trainee program. If the trainee program does not mention fringe benefits, trainees shall be paid the full amount of fringe benefits listed on the wage determination unless the Administrator of the Wage and Hour Division determines that there is an apprenticeship program associated with the corresponding journeyman wage rate on the wage determination which provides for less than full fringe benefits for apprentices. Any employee listed on the payroll at a trainee rate who is not registered and participating in a training plan approved by the Employment and Training Administration shall be paid not less than the applicable wage rate on the wage determination for the classification of work actually performed. In addition, any trainee performing work on the job site in excess of the ratio permitted under the registered program shall be paid not less than the applicable wage rate on the wage determination for the work actually performed.

In the event the Employment and Training Administration withdraws approval of a training program, the Contractor will no longer be permitted to utilize trainees at less than the applicable predetermined rate for the work performed until an acceptable program is approved.

3) Equal employment opportunity. The utilization of apprentices, trainees and journeymen under this part shall be in conformity with the equal employment opportunity requirements of Executive Order 11246, as amended, and 29 CFR part 30.

E. Compliance with Copeland Act requirements. The Contractor shall comply with the requirements of 29 CFR part 3, which are incorporated by reference in this contract.

F. Subcontracts. The Contractor or subcontractor shall insert in any subcontracts the clauses contained in 29 CFR 5.5(a)(1) through (10) and such other clauses as the (write in the name of the Federal agency) may by appropriate instructions require, and also a clause requiring the subcontractors to include these clauses in any lower tier subcontracts. The prime Contractor shall

be responsible for the compliance by any subcontractor or lower tier subcontractor with all the contract clauses in 29 CFR 5.5.

G. Contract termination: debarment. A breach of the contract clauses in 29 CFR 5.5 may be grounds for termination of the contract, and for debarment as a contractor and a subcontractor as provided in 29 CFR 5.12.

H. Compliance with Davis-Bacon and Related Act requirements. All rulings and interpretations of the Davis-Bacon and Related Acts contained in 29 CFR parts 1, 3, and 5 are herein incorporated by reference in this contract.

I. Disputes concerning labor standards. Disputes arising out of the labor standards provisions of this contract shall not be subject to the general disputes clause of this contract. Such disputes shall be resolved in accordance with the procedures of the Department of Labor set forth in 29 CFR parts 5, 6, and 7. Disputes within the meaning of this clause include disputes between the Contractor (or any of its subcontractors) and the PAG, the U.S. Department of Labor, or the employees or their representatives.

J. Certification of eligibility.

1) By entering into this contract, the Contractor certifies that neither it (nor he or she) nor any person or firm who has an interest in the Contractor's firm is a person or firm ineligible to be awarded Government contracts by virtue of section 3(a) of the Davis-Bacon Act or 29 CFR 5.12(a)(1).

2) No part of this contract shall be subcontracted to any person or firm ineligible for award of a Government contract by virtue of section 3(a) of the Davis-Bacon Act or 29 CFR 5.12(a)(1).

3) The penalty for making false statements is prescribed in the U.S. Criminal Code, 18 U.S.C. 1001.

CONTRACT WORK HOURS AND SAFETY STANDARDS ACT
(APPLICABLE TO ALL CONTRACTS AND SUBCONTRACTS EXCEEDING \$100,000
AND INVOLVING EMPLOYMENT OF MECHANICS AND LABORERS)

As used in these paragraphs, the terms laborers and mechanics include watchmen and guards.

A. Overtime requirements. No contractor or subcontractor contracting for any part of the contract Work which may require or involve the employment of laborers or mechanics shall require or permit any such laborer or mechanic in any workweek in which he or she is employed on such work to work in excess of forty hours in such workweek unless such laborer or mechanic receives compensation at a rate not less than one and one-half times the basic rate of pay for all hours worked in excess of forty hours in such workweek.

B. Violation; liability for unpaid wages; liquidated damages. In the event of any violation of this section, the Contractor and any subcontractor responsible therefore shall be liable for the unpaid wages. In addition, such Contractor and subcontractor shall be liable to the United States (in the case of work done under contract for the District of Columbia or a territory, to such District or to such territory), for liquidated damages. Such liquidated damages shall be computed with respect to each individual laborer or mechanic, including watchmen and guards, employed in violation of the clause set forth in this section, in the sum of \$10 for each calendar day on which such individual was required or permitted to work in excess of the standard workweek of forty hours without payment of the overtime wages required by this section.

C. Withholding for unpaid wages and liquidated damages. the PAG shall upon its own action or upon written request of an authorized representative of the Department of Labor withhold or cause to be withheld, from any moneys payable on account of work performed by the Contractor or subcontractor under any such contract or any other Federal contract with the same prime Contractor, or any other federally-assisted contract subject to the Contract Work Hours and Safety Standards Act, which is held by the same prime Contractor, such sums as may be determined to be necessary to satisfy any liabilities of such Contractor or subcontractor for unpaid wages and liquidated damages as provided in the clause set forth in this section.

D. Subcontracts. The Contractor or subcontractor shall insert in any subcontracts the clauses set forth in this section and also a clause requiring the subcontractors to include these clauses in any lower tier subcontracts. The prime Contractor shall be responsible for compliance by any subcontractor or lower tier subcontractor with the clauses set forth in this section.

SAFETY: ACCIDENT PREVENTION
(APPLICABLE TO ALL CONSTRUCTION CONTRACTS AND SUBCONTRACTS
EXCEEDING \$100,000)

A. In the performance of this contract the Contractor shall comply with all applicable Federal, State, and local laws governing safety, health, and sanitation. The Contractor shall provide all safeguards, safety devices and protective equipment and take any other needed actions as it determines, or as the contracting officer may determine, to be reasonably necessary to protect the life and health of employees on the job and the safety of the public and to protect property in connection with the performance of the work covered by the contract.

B. It is a condition of this contract, and shall be made a condition of each subcontract, which the Contractor enters into pursuant to this contract, that the Contractor and any subcontractor shall not permit any employee, in performance of the contract, to work in surroundings or under conditions which are unsanitary, hazardous or dangerous to his/her health or safety, as determined under construction safety and health standards (29 CFR 1926) promulgated by the Secretary of Labor, in accordance with Section 107 of the Contract Work Hours and Safety Standards Act (40 U.S.C. 3704).

C. Pursuant to 29 CFR 1926.3, it is a condition of this contract that the Secretary of Labor or authorized representative thereof, shall have right of entry to any site of contract performance to

inspect or investigate the matter of compliance with the construction safety and health standards and to carry out the duties of the Secretary under Section 107 of the Contract Work Hours and Safety Standards Act (40 U.S.C.3704).

D. Hazardous Materials.

(1) The Contractor is responsible for compliance with any applicable Federal, State, and local laws or requirements regarding hazardous materials. If the Contractor encounters a hazardous material or substance not addressed in this Agreement and if reasonable precautions will be inadequate to prevent foreseeable bodily injury or death to persons resulting from a material or substance, including but not limited to asbestos or polychlorinated biphenyl (PCB), encountered on the site by the Contractor, the Contractor shall, upon recognizing the condition, immediately stop Work in the affected area and report the condition to the PAG and the Project Manager in writing.

(2) The Contractor shall indemnify the PAG for the cost and expense incurred: (1) for remediation of a material or substance the Contractor brings to the site and negligently handles; or (2) where the Contractor fails to perform its obligations, except to the extent that the cost and expense are due to the PAG's fault or negligence.

E. Emergencies. In an emergency affecting safety of persons or property, the Contractor shall act, at the Contractor's discretion, to prevent threatened damage, injury or loss.

DRUG FREE WORKPLACE

A. The Contractor shall, within 30 days after award:

(1) Publish a statement notifying its employees that the unlawful manufacture, distribution, dispensing, possession, or use of a controlled substance is prohibited in the Contractor's workplace and specifying the actions that will be taken against employees for violations of such prohibition;

(2) Establish an ongoing drug-free awareness program to inform such employees about -

- (i) The dangers of drug abuse in the workplace;
- (ii) The Contractor's policy of maintaining a drug-free workplace;
- (iii) Any available drug counseling, rehabilitation, and employee assistance programs; and
- (iv) The penalties that may be imposed upon employees for drug abuse violations occurring in the workplace.

(3) Provide all employees engaged in performance of the contract with a copy of the statement required by paragraph (1) of this clause;

(4) Notify such employees in writing in the statement required by subparagraph (b)(1) of this clause that, as a condition of continued employment on this contract, the employee will -

- (i) Abide by the terms of the statement; and
- (ii) Notify the employer in writing of the employee's conviction under a criminal drug statute for a violation occurring in the workplace no later than 5 days after such conviction.

(5) Notify the Procurement Officer in writing within 10 days after receiving notice under subdivision (4)(ii) of this clause, from an employee or otherwise receiving actual notice of such conviction. The notice shall include the position title of the employee;

(6) Within 30 days after receiving notice under subdivision (4)(ii) of this clause of a conviction, take one of the following actions with respect to any employee who is convicted of a drug abuse violation occurring in the workplace:

(i) Taking appropriate personnel action against such employee, up to and including termination; or

(ii) Require such employee to satisfactorily participate in a drug abuse assistance or rehabilitation program approved for such purposes by a Federal, State, or local health, law enforcement, or other appropriate agency; and

(7) Make a good faith effort to maintain a drug-free workplace through implementation of paragraphs (1) through (6) of this clause.

B. The Contractor, if an individual, agrees by award of the contract or acceptance of a purchase order, not to engage in the unlawful manufacture, distribution, dispensing, possession, or use of a controlled substance while performing this contract.

C. In addition to other remedies available to the PAG, the Contractor's failure to comply with the requirements of paragraph (B) or (C) of this clause may render the Contractor subject to suspension of contract payments, termination of the contract for default, and suspension or debarment.

RIGHTS TO INVENTIONS MADE UNDER A CONTRACT OR AGREEMENT
(APPLICABLE TO ALL CONTRACTS INVOLVING EXPERIMENTAL,
DEVELOPMENTAL, OR RESEARCH WORK BY A SMALL BUSINESS ENTITY OR NON-
PROFIT ENTITY)

A. The Contractor must comply with all applicable requirements of 37 CFR Part 401, "Rights to Inventions Made by Nonprofit Organizations and Small Business Firms Under Government Grants, Contracts and Cooperative Agreements," and any implementing regulations issued by the OEA. The interpretation of this clause and this Agreement is subject to the definitions located at 37 CFR § 401.14.

B. The Contractor may retain the entire right, title, and interest throughout the world to each subject invention subject to the provisions of this clause and 35 U.S.C. 203. With respect to any subject invention in which the Contractor retains title, the Federal government shall have a nonexclusive, nontransferable, irrevocable, paid-up license to practice or have practiced for or on behalf of the United States the subject invention throughout the world.

C. **Invention Disclosure, Election of Title and Filing of Patent Application by Contractor**

1. The Contractor will disclose each subject invention to the OEA ("Federal Agency") within two months after the inventor discloses it in writing to Contractor personnel responsible for patent matters. The disclosure to the agency shall be in the form of a written report and shall identify the contract under which the invention was made and the inventor(s). It shall be sufficiently complete in technical detail to convey a clear understanding to the extent known at the time of the disclosure, of the nature, purpose, operation, and the physical, chemical, biological or electrical characteristics of the invention. The disclosure shall also identify any publication, on sale or public use of the invention and whether a manuscript describing the invention has been

submitted for publication and, if so, whether it has been accepted for publication at the time of disclosure. In addition, after disclosure to the agency, the Contractor will promptly notify the agency of the acceptance of any manuscript describing the invention for publication or of any on sale or public use planned by the Contractor.

2. The Contractor will elect in writing whether or not to retain title to any such invention by notifying the Federal agency within two years of disclosure to the Federal agency. However, in any case where a patent, a printed publication, public use, sale, or other availability to the public has initiated the one year statutory period wherein valid patent protection can still be obtained in the United States, the period for election of title may be shortened by the agency to a date that is no more than 60 days prior to the end of the statutory period.

3. The Contractor will file its initial patent application on a subject invention to which it elects to retain title within one year after election of title or, if earlier, prior to the end of any statutory period wherein valid patent protection can be obtained in the United States after a publication, on sale, or public use. If the Contractor files a provisional application as its initial patent application, it shall file a non-provisional application within 10 months of the filing of the provisional application. The Contractor will file patent applications in additional countries or international patent offices within either ten months of the first filed patent application or six months from the date permission is granted by the Commissioner of Patents to file foreign patent applications where such filing has been prohibited by a Secrecy Order.

4. For any subject invention with Federal agency and Contractor co-inventors, where the Federal agency employing such co-inventor determines that it would be in the interest of the government, pursuant to 35 U.S.C. 207(a)(3), to file an initial patent application on the subject invention, the Federal agency employing such co-inventor, at its discretion and in consultation with the Contractor, may file such application at its own expense, provided that the Contractor retains the ability to elect title pursuant to 35 U.S.C. 202(a).

5. Requests for extension of the time for disclosure, election, and filing under paragraphs (1), (2), and (3) of this clause may, at the discretion of the Federal agency, be granted. When a Contractor has requested an extension for filing a non-provisional application after filing a provisional application, a one-year extension will be granted unless the Federal agency notifies the Contractor within 60 days of receiving the request.

D. Conditions When the Government May Obtain Title

The Contractor will convey to the Federal agency, upon written request, title to any subject invention:

1. If the Contractor fails to disclose or elect title to the subject invention within the times specified in paragraph (C) of this clause, or elects not to retain title.

2. In those countries in which the Contractor fails to file patent applications within the times specified in paragraph (C) of this clause; provided, however, that if the Contractor has filed a patent application in a country after the times specified in paragraph (C) of this clause, but prior to its receipt of the written request of the Federal agency, the Contractor shall continue to retain title in that country.

3. In any country in which the Contractor decides not to continue the prosecution of any non-provisional patent application for, to pay a maintenance, annuity or renewal fee on, or to defend in a reexamination or opposition proceeding on, a patent on a subject invention.

E. Minimum Rights to Contractor and Protection of the Contractor Right to File

1. The Contractor will retain a nonexclusive royalty-free license throughout the world in each subject invention to which the Government obtains title, except if the Contractor fails to disclose the invention within the times specified in (C), above. The Contractor's license extends to its domestic subsidiary and affiliates, if any, within the corporate structure of which the Contractor is a party and includes the right to grant sublicenses of the same scope to the extent the Contractor was legally obligated to do so at the time the contract was awarded. The license is transferable only with the approval of the Federal agency except when transferred to the successor of that party of the Contractor's business to which the invention pertains.

2. The Contractor's domestic license may be revoked or modified by the funding Federal agency to the extent necessary to achieve expeditious practical application of the subject invention pursuant to an application for an exclusive license submitted in accordance with applicable provisions at 37 CFR part 404 and agency licensing regulations (if any). This license will not be revoked in that field of use or the geographical areas in which the Contractor has achieved practical application and continues to make the benefits of the invention reasonably accessible to the public. The license in any foreign country may be revoked or modified at the discretion of the funding Federal agency to the extent the Contractor, its licensees, or the domestic subsidiaries or affiliates have failed to achieve practical application in that foreign country.

3. Before revocation or modification of the license, the funding Federal agency will furnish the Contractor a written notice of its intention to revoke or modify the license, and the Contractor will be allowed thirty days (or such other time as may be authorized by the funding Federal agency for good cause shown by the Contractor) after the notice to show cause why the license should not be revoked or modified. The Contractor has the right to appeal, in accordance with applicable regulations in 37 CFR part 404 and agency regulations (if any) concerning the licensing of Government-owned inventions, any decision concerning the revocation or modification of the license.

F. Contractor Action to Protect the Government's Interest

1. The Contractor agrees to execute or to have executed and promptly deliver to the Federal agency all instruments necessary to: (i) establish or confirm the rights the Government has throughout the world in those subject inventions to which the Contractor elects to retain title; and (ii) convey title to the Federal agency when requested under paragraph (D) above and to enable the government to obtain patent protection throughout the world in that subject invention.

2. The Contractor agrees to require, by written agreement, its employees, other than clerical and nontechnical employees, to disclose promptly in writing to personnel identified as responsible for the administration of patent matters and in a format suggested by the Contractor each subject invention made under contract in order that the Contractor can comply with the disclosure provisions of paragraph (C) of this clause, to assign to the Contractor the entire right, title and interest in and to each subject invention made under contract, and to execute all papers necessary to file patent applications on subject inventions and to establish the government's rights in the subject inventions. This disclosure format should require, as a minimum, the information required by paragraph (C)(1) of this clause. The Contractor shall instruct such employees through employee agreements or other suitable educational programs on the importance of reporting inventions in sufficient time to permit the filing of patent applications prior to U.S. or foreign statutory bars.

3. For each subject invention, the Contractor will, no less than 60 days prior to the expiration of the statutory deadline, notify the Federal agency of any decision: Not to continue the

prosecution of a non-provisional patent application; not to pay a maintenance, annuity or renewal fee; not to defend in a reexamination or opposition proceeding on a patent, in any country; to request, be a party to, or take action in a trial proceeding before the Patent Trial and Appeals Board of the U.S. Patent and Trademark Office, including but not limited to post-grant review, review of a business method patent, *inter partes* review, and derivation proceeding; or to request, be a party to, or take action in a non-trial submission of art or information at the U.S. Patent and Trademark Office, including but not limited to a pre-issuance submission, a post-issuance submission, and supplemental examination.

4. The Contractor agrees to include, within the specification of any United States patent applications and any patent issuing thereon covering a subject invention, the following statement, "This invention was made with government support under the Agreement for Professional Technical Advisory Services between Contractor and OOG, awarded by the OOG under Federal Award Number HQ0005171035. The government has certain rights in the invention."

G. Subcontracts

1. The Contractor will include this clause, suitably modified to identify the parties, in all subcontracts, regardless of tier, for experimental, developmental or research work to be performed by a subcontractor. The subcontractor will retain all rights provided for the Contractor in this clause, and the Contractor will not, as part of the consideration for awarding the subcontract, obtain rights in the subcontractor's subject inventions.

2. The Contractor will include in all other subcontracts, regardless of tier, for experimental developmental or research work the patent rights clause required by the FAR or the Terms and Conditions of Federal Award Number HQ0005171035.

3. In the case of subcontracts, at any tier, when the prime award with the Federal agency was a contract (but not a grant or cooperative agreement), the OEA, subcontractor, and the Contractor agree that the mutual obligations of the parties created by this clause constitute a contract between the subcontractor and the Federal agency with respect to the matters covered by the clause; provided, however, that nothing in this paragraph is intended to confer any jurisdiction under the Contract Disputes Act in connection with proceedings under paragraph (J) of this clause.

H. Reporting on Utilization of Subject Inventions

The Contractor agrees to submit on request periodic reports no more frequently than annually on the utilization of a subject invention or on efforts at obtaining such utilization that are being made by the Contractor or its licensees or assignees. Such reports shall include information regarding the status of development, date of first commercial sale or use, gross royalties received by the Contractor, and such other data and information as the agency may reasonably specify. The Contractor also agrees to provide additional reports as may be requested by the agency in connection with any march-in proceeding undertaken by the agency in accordance with paragraph (J) of this clause. As required by 35 U.S.C. 202(c)(5), the agency agrees it will not disclose such information to persons outside the government without permission of the Contractor.

I. Preference for United States Industry

Notwithstanding any other provision of this clause, the Contractor agrees that neither it nor any assignee will grant to any person the exclusive right to use or sell any subject inventions in the United States unless such person agrees that any products embodying the subject invention or produced through the use of the subject invention will be manufactured substantially in the United

States. However, in individual cases, the requirement for such an agreement may be waived by the Federal agency upon a showing by the Contractor or its assignee that reasonable but unsuccessful efforts have been made to grant licenses on similar terms to potential licensees that would be likely to manufacture substantially in the United States or that under the circumstances domestic manufacture is not commercially feasible.

J. March-in Rights

The Contractor agrees that with respect to any subject invention in which it has acquired title, the Federal agency has the right in accordance with the procedures in 37 CFR 401.6 and any supplemental regulations of the agency to require the Contractor, an assignee or exclusive licensee of a subject invention to grant a nonexclusive, partially exclusive, or exclusive license in any field of use to a responsible applicant or applicants, upon terms that are reasonable under the circumstances, and if the Contractor, assignee, or exclusive licensee refuses such a request the Federal agency has the right to grant such a license itself if the Federal agency determines that:

1. Such action is necessary because the Contractor or assignee has not taken, or is not expected to take within a reasonable time, effective steps to achieve practical application of the subject invention in such field of use.

2. Such action is necessary to alleviate health or safety needs which are not reasonably satisfied by the Contractor, assignee or their licensees;

3. Such action is necessary to meet requirements for public use specified by Federal regulations and such requirements are not reasonably satisfied by the Contractor, assignee or licensees; or

4. Such action is necessary because the agreement required by paragraph (I) of this clause has not been obtained or waived or because a licensee of the exclusive right to use or sell any subject invention in the United States is in breach of such agreement.